

Steel Buildings



Publication No. 35/03

Steel Buildings



BCSA

Publication No. 35/03

Apart from any fair dealing for the purposes of research or private study or criticism or review, as permitted under the Copyright Design and Patents Act 1988, this publication may not be reproduced, stored or transmitted in any form by any means without the prior permission of the publishers or in the case of reprographic reproduction only in accordance with the terms of the licences issued by the UK Copyright Licensing Agency, or in accordance with the terms of licences issued by the appropriate Reproduction Rights Organisation outside the UK.

Enquiries concerning reproduction outside the terms stated here should be sent to the publishers, The British Constructional Steelwork Association Ltd at the address given below.

Although care has been taken to ensure, to the best of our knowledge, that all data and information contained herein are accurate to the extent that they relate to either matters of fact or accepted practice or matters of opinion at the time of publication, The British Constructional Steelwork Association Ltd, the authors and the co-ordinator assume no responsibility for any errors in or misinterpretation of such data and/or information or any loss or damage arising from or related to their use.

The British Constructional Steelwork Association Limited (BCSA) is the national organisation for the steel construction industry: its Member companies undertake the design, fabrication and erection of steelwork for all forms of construction in building and civil engineering. Associate Members are those principal companies involved in the purchase, design or supply of components, materials, services related to the industry. Corporate Members are clients, professional offices, educational establishments which support the development of national specifications, quality, fabrication and erection techniques, overall industry efficiency and good practice.

The principal objectives of the Association are to promote the use of structural steelwork; to assist specifiers and clients; to ensure that the capabilities and activities of the industry are widely understood and to provide members with professional services in technical, commercial, contractual and quality assurance matters. The Association's aim is to influence the trading environment in which member companies operate in order to improve their profitability.

A current list of members and a list of current publications and further membership details can be obtained from:

The British Constructional Steelwork Association Ltd

4 Whitehall Court, Westminster, London SW1A 2ES
Telephone: +44 (0) 20 7839 8566
Fax: +44 (0) 20 7976 1634
Email: postroom@steelconstruction.org

BCSA's website, www.SteelConstruction.org, can be used both to find information about steel construction companies and suppliers, and also to search for advice and information about steel construction related topics, view publications, etc.

Publication Number 35/03

First Edition November 2003

ISBN 0 85073 043 0

British Library Cataloguing-in-Publication Data

A catalogue record for this book is available from the British Library

© The British Constructional Steelwork Association Ltd

Designed and Printed by
Box of Tricks www.bot.uk.com

FOREWORD

Steel construction came into being in the late 19th and early 20th centuries as a natural development from earlier techniques that used cast and wrought iron. Yet, surprisingly, this is the first comprehensive book to be published on "Steel Buildings" covering such a wide range of topics as design, fabrication, construction, procurement, protective systems, contracts, health & safety and historical development. The term "buildings" is taken in a wide sense, meaning in this context virtually anything other than bridges – for which BCSA also publishes a companion book called "Steel Bridges".

In the UK, steel's market share of buildings compared to other media has increased significantly since around 1980 and is now the highest in the world. At that time steel's market share of framed single storey buildings was 65% and it is now 95% and of multi-storey buildings it was 30% and it is now 70%. This has not happened by accident but by a combined concerted push in market development, new construction solutions and, above all, improvements in efficiency and productivity.

There is so much to say on the topic of steel buildings that it would be impossible to cover everything in one volume and hence a comprehensive reference list is also given, including for example the National Structural Steelwork Specification for Building Construction and the Handbook of Structural Steelwork.

The authors of each chapter are experts in their particular fields and sincere thanks are given to them and the co-ordinator of the book, Dr Roger Pope.



Dr Derek Tordoff, Director General
The British Constructional
Steelwork Association Limited.

Structural Steel Design Award winners 2003

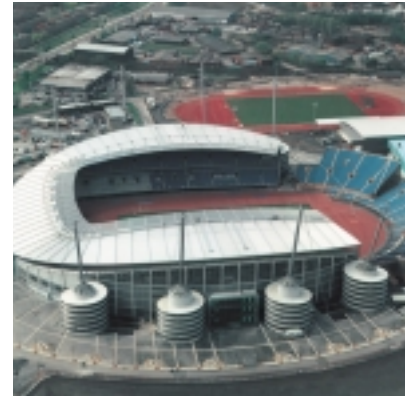

**City of Manchester Stadium -
Watson Steel Structures Ltd**



**New Hangars for TAG Farnborough Airport -
Rowecord Engineering Ltd**



Millennium Point Birmingham

CONTENTS

Chapter 1	Introduction to Steel Construction	
1	Benefits of Steel Construction	1
2	Client Brief	6
3	Factors Influencing Steelwork Prices and Lead Times	7
Chapter 2	Design	
1	Design Aims	11
2	Methods of Design	11
3	Loadings.	11
4	Limit State Design	11
5	Local Buckling.	12
6	Design of Beams.	12
7	Design of Ties.	14
8	Design of Struts	14
Chapter 3	Single Storey Buildings	
1	Introduction.	37
2	Procurement Routes	37
3	Structural Framing Options	38
4	Geometry and Layout	38
5	Construction Periods.	39
6	Co-ordinating the Supply Chain	40
7	Project Management	40
8	Safe Site Erection	40
9	Summary	41
Chapter 4	Multi-Storey Buildings	
1	Introduction.	43
2	Form and Concept	43
3	Foundations	44
4	Substructure	45
5	Superstructure Floor Construction	46
6	Building Services Integration	48
7	Lateral Stability	49
8	Robustness.	50
9	Cladding	51
10	Buildability.	52
Chapter 5	Design of Connections	
1	Introduction.	55
2	Connection Design	56
3	Recommended Material and Detail for Connections	56
4	Connection Criteria and Tables.	59
5	Typical Connections.	62

Chapter 6	Steel Manufacture	
1	The Early History	69
2	Iron Making	69
3	Steel Making	70
4	Casting Steel	71
5	Shaping Steel	72
Chapter 7	Steel Specification	
1	Mechanical Properties	73
2	Standards	73
3	Properties	74
Chapter 8	Plated Beams	
1	Introduction	77
2	Design	77
3	Ultimate Limit State	78
4	Provision for Building Services	79
5	Serviceability Limit State	79
6	Fire Limit State	80
7	Manufacture	80
8	Design for Manufacture	81
Chapter 9	Welding	
1	Introduction	83
2	Principles of Metal Arc Welding	83
3	Types of Joint	84
4	Processes	84
5	Preparation of Welding Procedure Specifications	87
6	Procedure Tests	87
7	Avoidance of Hydrogen Cracking	88
8	Welder Approval	89
9	Inspection and Testing	89
Chapter 10	Bolting	
1	Introduction	91
2	Standards for Structural Fasteners	91
3	Strength of Fasteners	94
4	Installation of Fasteners	95
5	Installation Methods for Preloaded Bolts	97
6	Specification and Other Issues	98
Chapter 11	Fabrication	
1	Introduction	99
2	Costs	99
3	Material and Components	101
4	Preparation	101
5	Assembly and Welding	103
6	Surface Treatment	104
7	Transport	104

Chapter 12	Corrosion Protection	
1	Introduction to Corrosion	107
2	The Influence of Design on Corrosion	108
3	Preparing for Corrosion Protection	108
4	Paint Coatings.	110
5	Metallic Coatings	111
6	The Protective Treatment Specification	113
Chapter 13	Fire Resistance	
1	Legal Requirements.	115
2	Fire Safety Engineering	116
3	Passive Fire Protection Methods.	117
4	Off-Site Fire Protection.	118
5	Inherent Fire Resistance.	118
6	Cardington Fire Tests and Design Guidance	119
7	Codes of Practice	119
8	Reinstatement of Fire Damaged Structures	119
9	Single Storey Buildings in Fire	120
10	Use of Sprinklers	120
Chapter 14	Erection	
1	Introduction.	121
2	Planning for Erection	124
3	Interfaces	124
Chapter 15	Specification & Quality	
1	Introduction.	127
2	Correct Specification	128
3	Quality Management	128
4	Problems in Practice	130
Chapter 16	Information	
1	Introduction.	141
2	Conflicting Information Requirements within the Supply Chain.	141
3	The Steelwork Contractor's Specific Needs.	142
4	'Efficient Steelwork Procurement through Improved Information Exchange'.	143
5	Addressing the Issues	145
Chapter 17	Software	
1	Introduction.	147
2	Software in Context.	147
3	3D Modelling.	148
4	Information Exchange	149
5	The Building Information Model Debate	151

Chapter 18	Selection of Steelwork Contractors and Suppliers	
1	Introduction	153
2	Industry Organisation	153
3	Certification	155
4	Registration	156
Chapter 19	Contracts and Payments	
1	Introduction	161
2	Early Involvement of Steelwork Contractors in Design . . .	161
3	Sign-off of Design	162
4	Programme	163
5	Variations and Valuation of Structural Steelwork	163
6	Payment	164
7	Retentions	165
8	General	166
Chapter 20	Health & Safety	
1	Introduction	167
2	Hazard, Risk and Competence	168
3	Method Statement Development	170
4	Stability	172
5	Best Practice	173
Chapter 21	Sustainable Construction	
1	What is Sustainable Construction?	175
2	Drivers for Sustainability	175
3	Understanding Sustainable Development	176
4	Informed Decision Making and Whole Life Considerations	176
5	Design for Long Life and Low Maintenance	177
6	Speed and Efficiency of Construction	177
7	Efficient Operation	178
8	Recycling and Re-use	178
9	Supply Chain Engagement	179
Chapter 22	Building Envelope	
1	Introduction	181
2	The Proposed Design and Application	181
3	Weatherproofing	181
4	Thermal Performance	182
5	Fire Performance	183
6	Structural Support	183
7	Roof Drainage	184
8	Durability	185

Case Studies

City of Manchester Stadium	188
New Hangars for TAG Farnborough Airport	190
Millennium Point, Birmingham	192
TNT FastTrack, Magna Park, Lutterworth	194
The Wellcome Wing at the Science Museum, London.	196
The Eden Project, Bodelva, Cornwall	198
Renewal and Refurbishment of the Brighton Dome and Museum.	200
25 Gresham Street, London	201
Hampden Gurney School, London	202
Tattersalls Grandstand, Newbury Racecourse.	203
Premier Place, Devonshire Square, London	204
The Lowry, Salford Quays, Manchester	205

Early History of Structural Steelwork in Great Britain

Chapter 1 – Before 1885.	209
Chapter 2 – 1885 to 1900.	217
Chapter 3 – 1900 to 1910.	223
Chapter 4 – 1910 to 1920.	227
Chapter 5 – 1920 to 1930.	233
Chapter 6 – 1930 to 1939.	239
Chapter 7 – 1939 to 1945.	245
Chapter 8 – 1945 to 1950.	249
Chapter 9 – A Brief Summary of Developments in the Steel Construction Industry from the 1950s to 2000.	253

CHAPTER 1

Introduction to Steel Construction

1 Benefits of Steel Construction

With today's structural steel framing, grace, art and function can come together in almost limitless ways; steel construction offers new solutions and opportunities, allowing architects to stretch their imagination and actually create some of the most challenging structures they have designed in their minds. What was once thought impossible is now a reality.

This chapter explains the benefits of choosing steel construction and also the issues which need to be considered by the client/specifier/designer in order to obtain an optimum solution, such as the brief, the design and construction process, and the factors which influence prices and lead times.

The key benefits of steel construction include:

- low cost
- strength
- durability
- design flexibility
- adaptability
- recyclability

These and other benefits continue to make steel the material of choice for building frame construction.

Structural steel has entered a new era. Today it provides not only strength to buildings, but also beauty and drama – enhancements which are difficult or too costly to produce with other materials. Advanced steel fabrication technology has unfolded exciting architectural opportunities, allowing architects to expand their artistic expression and design spectacular structures with steel.

Curving and bending is now possible in ways that were never thought possible before. Depending upon the size and radius of the desired curve, beams can be bent up to 360 degrees. Curves using steel beams bent to a certain radius or segmented curves or combinations of both can create members that follow the outlines of irregular façades, arches or domes.



City of Manchester Stadium - Watson Steel Structures Ltd

1.1 Accuracy and Precision

Today's precision fabrication allows steel pieces to be combined in unprecedented ways. Special steel sections, unusual angles and detailing are now economically viable thanks to CAD programs and computer-controlled cutting, punching and welding.

Architects' artistic freedom is further enhanced by the variety of steel shapes that can be worked with to perform special functions. Regardless of its shape, structural steel will carry required loads using a minimal amount of material. And, as building styles change, steel structures are easily re-designed by adding new façades or other architectural treatments.

Scaling down building height is important in controlling costs. Eliminating half a metre from each floor will cut the costs for steel and other building materials. From an energy-efficiency standpoint, minimising floor-to-floor heights also helps curb heating and cooling costs.

Running mechanical systems through web openings is one solution for minimising building heights. Another way is integrating floor beams into interior walls or partitions. Keeping the floor layout in mind takes careful planning but results in an efficient design.

In some cases, it is possible to limit the depth of beams by choosing a member size that is shallower, though heavier, yet still offers the same required strength. In the past, this was usually not economical, but with today's relatively lower structural steel costs, it has become a reasonable solution.

"Slimflor" and the Asymmetric Beam provide exciting new alternatives. These both promote the opportunity to limit the depth of the floor to the depth of the beam and the thickness of the concrete cover over the decking.

Steel beams may include web openings for aesthetic or functional purposes while still allowing the beams to carry the required loads. This creates a light and airy appearance.

Piping and ductwork can pass through the beam openings instead of being housed in a separate layer above or below each floor. This helps reduce the overall height of a structure, resulting in material and operating cost savings.

Computer software is available that helps engineers determine how large openings can be, where they can be located and whether or not they need to be reinforced. Web openings can even be added at a later date if needed.



Serpentine Gallery – William Hare Ltd

1.2 Strength

Steel's high strength-to-weight ratio enables it to span large distances gracefully and economically – more so than any other building frame material. In single storey buildings rolled beams can provide clear spans of over 50 metres, while using trussed or lattice construction can stretch this to more than 150 metres.

The long spanning capability of steel also enables the creation of large areas of unobstructed space in multi-storey buildings. While short to medium span steel systems will typically provide the lowest construction costs for the structural frame, many clients now demand the increased flexibility which only steel can provide with column spacings of 15 metres and more.



The Boiler Shop, Chatham Maritime – Caunton Engineering Ltd



Water Treatment Works, Lowestoft - Westbury Structures Ltd



"Marsyas", sculpture commissioned by Anish Kapoor for Tate Modern - S H Structures Limited

Steel transfer girders may bridge two points to create column-free spaces by eliminating columns. The Vierendeel truss, in particular, does not use any diagonal members, which can otherwise inhibit sight lines and traffic flow.

Fewer columns make it easier to subdivide and customise office space for current and future tenants. Open space also is more attractive to speculative buyers and commands a premium price in a competitive market.

In warehouses or manufacturing facilities, fewer columns mean less restrictions on the location of fixed equipment, as well as fewer obstructions when operating forklifts and other material handling equipment. It is also much easier to accommodate a variety of industrial tenants' floor-plan needs when an area has fewer columns.

When designing a building in extreme wind or earthquake zones, the first concern is protecting the people who live and work in the structure. The second consideration is preserving the contents of the building, such as expensive computer systems or irreplaceable documents. The last, though still important, concern is the condition and reparability of the building.

Steel is the material of choice for design because it is inherently ductile and flexible. It naturally flexes under extreme loads rather than crushing or crumbling. Additionally, steel structures have reserves of strength. Many of the beam-to-column connections in a building are designed to support vertical or gravity loads only. But they also have the capacity to resist lateral loads caused by wind and earthquakes. In their entirety, these connections provide considerable strength reserves beyond those usually considered in the building design.

1.3 Flexibility

Building owners often are faced with the challenge of modifying an existing space to meet changing needs – perhaps adding a new staircase, elevator or column-free space, or even raising or lowering a ceiling. Changes during occupation may also be necessary to comply with legislation such as the need to provide access for the disabled.

Steel is the only material that allows the strength of a structure to be increased economically once it is built. This is critical when a tenant would like to increase floor loads by adding such things as file storage, computer systems, mechanical units or hospital diagnostic equipment. Non-composite steel beams can be made composite with the existing floor slab or cover plates may be added to the beams for increased strength. Additional steel may also be bolted or welded to the existing steel

framework. Beams and girders can be easily reinforced, supplemented with additional framing or even relocated to support changed loads.

Connections can be strengthened. These strategies may also be applied to industrial buildings, where increased loads can be created by changes in the manufacturing process or the installation of new equipment that requires support from the overhead framing.

Additionally, walls can be repositioned to accommodate new interior layouts based on changing traffic patterns and space usage. This is possible because the interior and exterior walls of steel-framed buildings are not load bearing.

Electrical wiring, computer networking cables and communication systems are also constantly being upgraded or modified in today's high-tech offices. Steel framing and floor systems allow easy access to the wiring without disrupting the operations of the facility or the workers in the area.

1.4 Sustainability

Steel is a sustainable construction material. The Government's sustainability strategy for the construction sector concluded that, for long-term

success, construction must be seen to be socially and environmentally responsible as well as economically viable. This demands prudent use of natural resources, avoiding pollution, reducing waste, energy efficient design, effective management, staff health, safety and welfare, good community relations, project quality, delivery, productivity and profitability.

Though re-cycling and re-use are essential to minimise the energy used and the environmental impact of producing steel, sustainability benefits can be magnified by good design. Current design standards and codes of practice are geared to making optimum use of materials. Long-span structures promote adaptation and re-use. The adoption of CAD/CAM and new fabrication technology has improved productivity, reduced waste and enhanced competitiveness. It has also assisted the move to off-site manufacture giving better quality and fewer defects.

Modular technologies and the emphasis on off-site fabrication have reduced risks and improved the health and safety of the workforce. They contribute to the development of communities, better working conditions and training



Canary Wharf, London – 72,300 tonnes of steelwork supplied by Cleveland Bridge UK Ltd



Roof Decking, Airbus (UK) Ltd, Broughton – Corus Panels & Profiles



Ficep A152 CNC Punching and Shearing Line for Angles

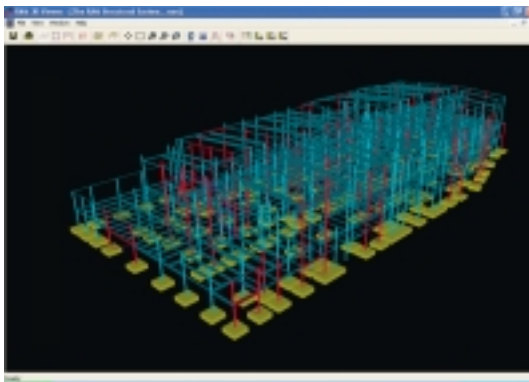

Carnaby Structures Ltd used the RAM Structural System to provide a fast economic solution for the Oxford Leisure Complex



Kinnaird House, 1-2 Pall Mall East, London - Bourne Steel Ltd

opportunities based on a stable workforce rather than on itinerant workers. In addition, factory-based work is more easily controlled and has less adverse impact on its environment than comparable on-site activities.

1.5 Speed

The speed at which a building is built is critical. Earlier occupancy means an office owner can begin renting space sooner, a factory owner can start producing products faster and the store operator can bring in sales pounds quicker.

Fast construction also lowers financing costs and overhead expenses for construction management services.

Because structural steel is lighter than other framing materials, it needs a smaller and simpler foundation. This reduces both cost and the time spent on construction.

Steel framing's simple "stick" design allows construction to proceed rapidly from the start of erection. Once the frame and steel floor decking are in, other building trades can begin their work using the deck as a working surface. It is common for electricians and other trades to be well into their work before the concrete slab is put in place. Additionally, properly stabilised steel can be loaded immediately, enabling work to commence on the next level without delay.

Adverse weather conditions, unless extreme, do not impede the progress of steel erection. It is not necessary for additional inspection services, which cause further delays, because steel maintains its quality despite the weather.

1.6 Productivity

The industry has made dramatic improvements in technology, productivity and efficiency, helping it to maintain strong exports of steelwork and related products and services. Around 10% of the UK's annual steelwork production is exported world-wide and UK companies continue to win important orders against overseas competition, with large contracts in Japan, Hong Kong, the Middle East, Africa, South America and Europe.

In the UK market, 80% of all non-domestic framed construction is steel. The past 20 years has seen the industry winning 95% of all single storey framed construction and 70% of all multi-storey construction.

Being totally re-usable, steel is the ultimate environmentally friendly product. Today's steel structures will almost certainly be re-used in the buildings of tomorrow.

2 Client Brief

Every construction project starts with a client defining a need. The client could be an individual, but is more likely to be a company, local authority or department of national government. To achieve the client's goal, a team must be assembled, design must be undertaken and contracts must be arranged.

2.1 Teamwork

A steel structure is the product of a highly professional team. Like any successful sporting team, every team member makes a vital contribution in achieving the right final result.

The steel construction team includes architects, design engineers, quantity surveyors, contractors, steelwork contractors, erectors, steel producers and specialist suppliers.

BCSA provides guidance on steel construction issues, including publications covering specification, design, assessment, contracting, finance, health and safety; many of these can be viewed free on www.SteelConstruction.org.

2.2 Structural Design

Most design engineers are now computer literate and make use of recognised and approved design software programs, which invariably save time and improve quality. They must also be familiar

with national standards, industry standards and building regulations to ensure that they are incorporated into the finished design. Relevant standards include BS 5950 for buildings and the National Structural Steelwork Specification for Building Construction. Armed with this knowledge, they work out the layout, size and type of steel structure needed to fulfil the client brief in the most cost-effective way.

When completed, the design specification becomes part of the tender documentation, which is submitted to the client for approval.

2.3 Tender/Award of Contracts

The translation of the client brief into tender documentation commences in tandem with the design specification. The full tender is normally submitted through a competitive tender process and involves input from those involved in the commercial side of the project, as well as from the design and manufacturing side. These include the project management team, architects and quantity surveyors.

Steelwork tenders are vetted commercially, technically and contractually by the client, main/management contractor and their advisers, who decide upon the most attractive offer and award a contract.



Baltic Quays Residential Block, Gateshead – Severfield-Reeve Structures Ltd

3 Factors Influencing Steelwork Prices and Lead Times

There is a wide range of factors that influence tender prices for structural steelwork. In general the factors are either commercial or technical. Guidance is given below on the key factors, together with information on lead times.

3.1 Commercial Factors

The following are commercial factors that should be considered when estimating the cost of steel construction projects.

History of parties involved

As with any specialist work, the degree of risk is significantly dependent upon the trust that each of the parties has in the others. When the parties (client, engineer, main/management contractor and steelwork contractor) have successfully worked together in the past, a lower price for the work, with fewer post-contract claims, can be expected.

Expertise of the Engineer

Some consulting engineers are more used to designing steel construction projects than others, with resulting simplicity and economy in their designs that will reduce total costs.

Contract Conditions

Comparatively aggressive terms and conditions will result in higher prices from specialist contractors such as steelwork, which requires significant investment in materials and fabrication processes before any completed work arrives on site. Making interim payments for work and materials in the process of being fabricated, but not yet delivered or erected, will often lower the overall steelwork costs and improve contingency planning. Similarly, the system of deduction of cash retentions is inefficient and is no longer operated in a number of areas of specialist contracting, including steelwork.

Market Conditions

Current order levels and mix of work/fabrication shop loading characteristics will affect price levels. When negotiating with or inviting potential steelwork contractors for a particular project, it is sensible to ascertain how busy they are in terms of their total design, detailing, fabrication and erection capacity when the work is to be placed.

Complete "Frame Package"

Many steelwork contractors are able to undertake additional work packages, for example concrete work, fire protection, decking and cladding. Also the larger the project the greater the scope is for economies of scale, for example a special



Ikea, Peterborough – Billington Structures Ltd



Shopping Centre, Dundalk Carons Village – Ballykine Structural Engineers Ltd



Car Park, Amersham – Conder Structures Ltd

production line can be set up for repetitive components.

Site Organisation

Good site co-ordination will facilitate a smooth running project. "Closed" sites in central city locations, as well as remote sites, necessitate premiums due to transport and logistics. Ensure that there is adequate access for steel transportation, unloading and erection, both on the site as well as on surrounding or adjacent access roads. Ensure that there is sufficient well prepared level ground that is adequate to take the requisite wheel loads. Ensure that everyone is aware of the need to comply with the BCSA Safe Site Handover Certificate and maintain its provisions.

Ensure that pre-site co-ordination is defined and that where the crane is to be supplied by others, it will always be available in accordance with the agreed erection schedule. Ensure that all foundation work will be completed within the agreed schedule and that all anchor bolts will be set in place within the specified tolerances, free from damage and contamination. All work to be connected to or dependent upon the steelwork needs to be properly identified as to whether the steelwork contractor is responsible for supplying and/or installing it, or it is the responsibility of others.

3.2 Technical Factors

Noted below are a number of general technical factors that apply to most projects. Some relate to the complexity of the particular project, whilst others are specific to the type of project, eg multi-storey, portals, trusses.

Specification

Conformance with the National Structural Steelwork Specification for Building Construction (NSSS) will reduce uncertainty. More demanding tolerances or testing than that specified in the NSSS will increase costs.

Bay Size

Structural steelwork prices are influenced by the size of each individual piece (ie number of pieces per tonne), which is largely dependent on bay size. Consider larger bay sizes, where the extra weight due to longer spans may be totally offset by the reduced price per tonne and the saving in number of columns and related workmanship. Also the resultant column-free space generally adds value to a project.

Structural steel frames must have the required degree of lateral resistance to wind loads. This can be provided by a stiff core or by the frame itself – diagonal steel bracing is usually a less expensive solution than moment frames.

Complexity

Modern CNC fabrication equipment can cope with complex individualistic designs but, in general, the more complex the fabrication required the greater the cost. Fabrication is more economic with:

- single cut square ends to reduce set-up times
- one hole diameter on any one piece to avoid drill bit changes
- holes in flanges and webs aligned where possible to facilitate drilling



Fox Road Stand, Trent Bridge, Nottingham – D A Green & Sons Ltd



Long Bar Stacker Crane –
supplied by Demag Cranes & Components Ltd

- web holes having adequate flange clearance to avoid tool clashes
- rationalised range of fittings in connections to increase repetition
- connections pre-drilled then welded or bolted to the main member

Wherever possible, leave the choice of the connection detail to the steelwork contractor as the type and design of connections directly influences the total frame cost. Rationalise the range and tonnages of section sizes used.

Complex individualistic designs are going to cost more per tonne, even with modern CNC equipment. If you wish to keep costs down – keep it simple!

Materials

Avoid mixing steel grades where possible and rationalise the range of section sizes/tonnages used in order to minimise cost, lead times and shop handling. In general steel grade S275 will be adequate, unless the strength requirements of grade S355 are essential.

Ensure that the most appropriate sections are specified for the particular application. “I” sections are usually most economical in conventional framing, while tubular sections are a possible alternative for columns as well as for long span trusses. While tubular sections are higher in first cost than “I” sections, their lower overall gross weight required to perform the same function can often offset this, usually with an “aesthetic bonus”. Asymmetric beams are frequently used as part of a reduced construction-depth floor system. Plate is usually used to fabricate economic “I” sections for longer spans and in connections, stiffeners and base plates.

Architectural Influence

Ensure that unnecessary finishing is not specified and that any applied corrosion resistant coating is appropriate for the environmental conditions to be encountered. Grinding of welds is usually only required for exposed steel in close proximity to a building’s occupants.

Quality of Engineering and Documentation

Completeness and accuracy of information are vital for a steelwork contractor to be able to properly assess the work involved. Where the steelwork is pre-designed, ensure that all member sizes are shown and that the connection forces are shown or are available.



West Bromwich Bus Station – The Angle Ring Co Ltd

3.3 Lead Times

Steel construction “lead time” figures of, say, 10 to 12 weeks are often quoted in journals. The figures usually quoted are in fact overall “length of order book” which is not necessarily compact.

The information that specifiers really need to know is the elapse time from placing an order to the time of start of delivery of steelwork to site and commencement of erection. Obviously this varies depending upon the size and complexity of the project, but for relatively straightforward projects the period from receipt of order with full information to start of delivery would typically be around 6 to 8 weeks.

Similarly erection times can vary depending upon location and complexity of the project, but for, say, an 8-storey office building, these are typically around 1,500 m² of floor area per week, using two cranes.



Slimdek® - Corus Construction & Industrial



Screwfix Direct project, Stoke-on-Trent – Atlas Ward Structures Ltd



Baltic Quay, Gateshead – decking supplied by Structural Metal Decks Ltd

CHAPTER 2

Design

1 Design Aims

The aim of the design process is to ensure that the structure is capable of resisting the anticipated loading with an adequate margin of safety and that it does not deform excessively during service. Due regard must be paid to economy which will involve consideration of ease of manufacture, including cutting, drilling and welding in the fabrication shop and transport to site. Under the CDM Regulations the designer has an obligation to consider how the structure will be erected, maintained and demolished. Further detailed information on steelwork design can be obtained from The Handbook of Structural Steelwork (published by BCSA and SCI) from which the following extracts are taken; the Notes in the tables refer to that publication.

2 Methods of Design

Historically, engineers have been accustomed to assume that joints in structures behave as either pinned or rigid to render design calculations manageable. In 'simple design' the joints are idealised as perfect pins. 'Continuous design' assumes that joints are rigid and that no relative rotation of connected members occurs whatever the applied moment. The vast majority of designs carried out today make one of these two assumptions, but another alternative is possible, which is known as semi-continuous design.

2.1 Simple Design

Simple design is the most traditional approach and is still commonly used. It is assumed that no moment is transferred from one connected member to another, except for the nominal moments which arise as a result of eccentricity at joints. The resistance of the structure to lateral loads and sway is usually ensured by the provision of bracing or, in some multi-storey buildings, by concrete cores.

2.2 Continuous Design

In continuous design, it is assumed that joints are rigid and transfer moment between members. The stability of the frame against sway is by frame action (ie by bending of beams and columns). Continuous design is more complex than simple design therefore software is commonly used to analyse the frame. Realistic combinations of pattern loading must be considered when designing continuous frames. The connections between members must have different characteristics depending on whether the design method for the frame is elastic or plastic.

2.3 Semi-continuous Design

True semi-continuous design is more complex than either simple or continuous design as the real joint response is more realistically represented. A simplified procedure exists for unbraced frames whereby the beam/column joints are assumed to be pinned when considering gravity loads; however, under wind loading they are assumed to be rigid, which means that lateral loads are carried by frame action.

3 Loadings

The principal forms of loading associated with building design are:

(i) Dead loading

This loading is of constant magnitude and location, and is mainly the self-weight of the structure itself.

(ii) Imposed loading

This is loading applied to the structure, other than wind, which is not of a permanent nature. Gravity loading due to occupants, equipment, furniture, material which might be stored within the building, demountable partitions and snow loads are the prime sources for imposed loads on building structures. BS 6399-1 should be consulted for imposed loadings. Note that in some cases clients may request that structures be designed for higher imposed loads than those specified in BS 6399-1.

(iii) Wind loading

Wind produces both lateral and (in some cases) vertical loads. Wind may blow in any direction, although often only two orthogonal load-cases are considered.

Note: the Eurocodes introduce the concept of permanent loads, which are not just dead loads but may be permanent imposed loads, as distinct from variable loads that are time-varying such as wind and snow loads.

4 Limit State Design

To cater for the inherent variability of loading and structural response, engineers apply factors to ensure the structure will carry the loads safely. Design used to be largely based on an allowable stress approach. The maximum stress was calculated using the maximum anticipated loading on the structure and its value was limited to the yield stress of the material divided by a

single global factor of safety. Serviceability deformations were calculated using these same maximum anticipated loadings. However, this approach gave inconsistent reserves of strength against collapse. The method is now superseded by a limit state approach in which the applied loads are multiplied by partial factors, and capacities and resistances are determined using the design strength of the material which is its characteristic strength divided by a partial safety factor. Limit states are the states beyond which the structure becomes unfit for its intended use. BS 5950-1 is a limit state design standard.

The values of the partial safety factors given in British Standards, which vary from load case to load case, reflect the probability of these values being exceeded for each specified situation. Reduced values of the partial safety factor are given when loadings are combined, as it is less likely that, for example, maximum wind will occur with maximum imposed load. This can be seen from Table 2 of BS 5950. The part of this table relevant to buildings not containing cranes is reproduced below.

4.1 Ultimate Limit States

The ultimate limit state (ULS) concerns the safety of the whole or part of the structure. In buildings without cranes, the principal load combinations which should be considered are:

Load combination 1: Dead load + imposed load

Load combination 2: Dead load + wind load

Load combination 3: Dead load + imposed load + wind load.

Partial load factors γ_f for buildings without cranes

Type of building and load combination	Factor γ_f
Dead load	1.4
Dead load with wind load and imposed load	1.2
Dead load when it counteracts the effects of other loads	1.0
Dead load when restraining sliding, overturning or uplift	1.0
Imposed load	1.6
Imposed load acting with wind load	1.2
Wind load	1.4
Wind load acting with imposed load	1.2
Storage tanks including contents	1.4
Storage tanks empty, when restraining sliding, overturning or uplift	1.0
Exceptional snow load (due to local drifting on roofs)	1.05

4.2 Serviceability Limit State

Serviceability limit state (SLS) corresponds to the limit beyond which the specified service criteria are no longer met. Serviceability loads are generally taken as unfactored imposed loads, but there are some exceptions. Further guidance is given in Clause 2.5.1 of BS 5950-1. Serviceability criteria include deflection, vibration and durability.

5 Local Buckling

The cross-section of most structural members may be considered to be an assembly of flat plate elements. As these plate elements are relatively thin, they may buckle locally when subjected to compression forces.

BS 5950-1 sets out a practical conservative approach suitable for most design situations to ensure that local buckling does not occur.

6 Design of Beams

6.1 General

A beam is a member that carries loading primarily in bending and which spans between supports or between connections to other members. This section deals with the design of beams in steel-framed buildings, designed according to BS 5950-1.

6.2 Span

In Clause 4.2.1.2 of BS 5950, the span of a beam is defined as the distance between effective points of support. In beam/column building frames, the difference between these support centres and the column centres is so small that it is customary to take the span as the distance between column centres when calculating moments, shears and deflections.

6.3 Loading

Loading may be classified as dead or imposed load. Dead loads are the permanent loads, typically including self weight of the steel, floors, roofs and walls. Imposed loads are variable, typically including crowd loading, storage, plant and machinery.

6.4 Lateral-torsional Buckling

If an "I" section is subject to vertical loading that can move laterally with the beam, the imperfections of the beam mean it will tend to distort as indicated in the figure below, which shows one half of a simply supported beam. Due to the bending action, the upper flange is in compression and acts like a strut. Being free to move, the compression flange will tend to buckle sideways dragging a reluctant tension flange

behind it. The tension flange resists this sideways movement and therefore, as the beam buckles, the section also twists, with the web no longer vertical. This action is known as lateral-torsional buckling.

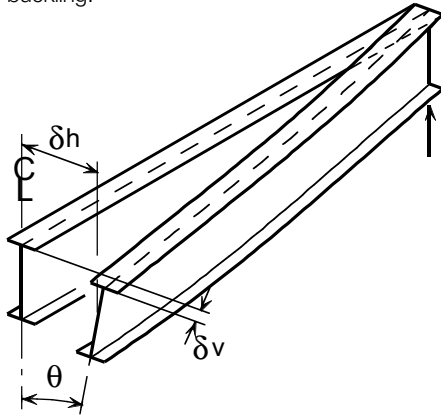

Lateral-torsional buckling – distorted shape of one half of a simply supported beam

6.5 Fully Restrained Beams

Lateral-torsional buckling will be inhibited by the provision of lateral restraints to the compression flange. If the flange is restrained at intervals, lateral torsional buckling may occur between the restraints and this must be checked. If this restraint is continuous, the beam is fully restrained and lateral-torsional buckling will not occur.

Full (continuous) lateral restraint is provided by:

- (i) in-situ and precast flooring or composite decking, provided that the flooring is supported directly on the top flange or is cast around it
- (ii) timber flooring, if the joists are fixed by cleats, bolts or other method providing a positive connection
- (iii) steel plate flooring, if it is bolted or welded at closely spaced intervals.

The continuous restraint should be designed to resist a force that is specified in the BS 5950-1 as 2.5% of the maximum force in the compression flange. This restraining force may be assumed to be uniformly distributed along the compression flange. This force must be carried by the connection between the flooring and the beam.

Note that the restraint must be to the compression flange. Special care is required when considering regions where the bottom flange is in compression.

6.6 Shear and Moment Capacities

The calculation of shear capacity P_v is set out in BS 5950-1 in Clause 4.2.3. The shear capacity P_v of an I or H section is calculated as:

$$P_v = 0.6 p_y A_v$$

where A_v is equal to the section depth times the web thickness.

The determination of the moment capacity of a beam M_c (effectively the moment capacity of the cross section, taking account of its classification) is given by Clause 4.2.5 of BS 5950-1. In the presence of low shear (applied shear $\leq 0.6 P_v$), M_c is given by:

$M_c = p_y S_x$ for Class 1 plastic and Class 2 compact sections

$M_c = p_y S_{x\text{eff}}$ or $p_y Z_x$ (conservatively) for Class 3 semi-compact sections.

To avoid irreversible deformation at serviceability loads, M_c should be limited to $1.5 p_y Z$ generally and $1.2 p_y Z$ for simply supported beams.

If the shear force exceeds $0.6 P_v$ then the moment capacity M_c needs to be reduced, as set out in Clause 4.2.5.3 of BS 5950-1. It should be remembered that in most beams the maximum moment occurs at a position of low shear; the exception being cantilevers where maximum moment and maximum shear occur together at the support.

In beams with full restraint, the design bending moments in the beam are simply checked against the above moment capacity. In beams without full restraint, the design bending moments must also be checked against the buckling resistance moment, as discussed below.

6.7 Design of Beams without Full Lateral Restraint

When lateral-torsional buckling is possible, either over the full span of the beam or between intermediate restraints, the resistance of the beam to bending action will be reduced by its tendency to buckle. According to Clause 4.3.6.2, the beam is checked by calculating a buckling resistance moment M_b , and an equivalent uniform moment factor m_{LT} . The requirement is that, in addition to checking the moment capacity (as above), the following should be satisfied:

$$M_x \leq M_{cx} \text{ and } M_x \leq M_b / m_{LT}$$

The value of the buckling resistance depends on determination of a bending strength p_b (generally, less than the material design strength p_y). Values of p_b may be obtained from Table 16 of BS 5950.

7 Design of Ties

Members which carry pure tension, generally referred to as ties, are relatively simple to design. In reality tension forces are frequently accompanied by moments and the member must be designed for the combined effects.

The tension capacity P_t of a tie is given in Clause 4.6.1 as:

$$P_t = p_y A_e$$

where:

A_e is the effective net area of the member.

A_e is found by the addition of the effective net areas a_e of all the elements in the cross-section. For each element, a_e is given in Clause 3.4.3 as:

$$a_e = K_e a_n \text{ but } \leq a_g$$

where:

a_e is the net area of the element allowing for bolt holes

a_g is the gross area of the element

K_e is a factor depending on the grade of steel, being 1.2 for S275 and 1.1 for grade S355.

In members where the bolt holes are not staggered, the area to be deducted is the sum of the cross-sectional areas of the holes in a cross-section perpendicular to the direction of the axial force. In members where the holes are staggered, the deduction is greater than the above

8 Design of Struts

Compression members, which carry pure compression, are often referred to as struts. Building columns generally carry both axial compression and bending and must be designed for the combined effects.

8.1 General

Members in compression have a limit on their load carrying capacity, known as the squash load, which is equal to the yield strength multiplied by the cross-sectional area. Long slender struts will fail at much lower loads by elastic buckling. However most practical compression members have a slenderness between these two extremes and will fail by a combination of yielding and buckling.

8.2 Effective Length

The end restraint conditions of a strut will affect the buckled shape of a strut and also the buckling resistance. The effective length is best described as the length of a pin-ended member that would behave like the real member with its actual end restraints. Thus a vital step in the design of any compression member is the identification of the effective length.

The table below shows the buckled shapes and effective lengths (as given in BS 5950, Table 22) for some reference conditions. Firstly, they are separated into non-sway and sway conditions. Relative movement of the ends of the strut are restricted in a non-sway frame, this can be achieved by effective diagonal bracing or by the provision of shear walls – possibly as the concrete core around lift shafts and stair wells. However, if the building relies on frame action for its lateral stability, it is more likely to be a sway-sensitive frame.

Strut effective lengths L_E

Restraint	Position	Position & Direction	Position & Direction	None	Direction
Shape					
L is strut length					
Restraint	Position	Position	Position & Direction	Position & Direction	Position & Direction
Practical L_E	$1.0L$	$0.85L$	$0.7L$	$2.0L$	$1.2L$

If the ends of a non-sway member have no rotational restraint, then the effective length of the strut is the actual length – by definition. If effective rotational restraint is present – for example from stiff beams that are effectively fastened to the column by stiff end plate connections – then the strut will be more resistant to buckling and the effective length will be reduced. In the extreme case of a non-sway strut which is fully restrained against rotation the effective length will be one half of the actual length. This is an idealised reference case, because full rotational restraint is not achievable in practice and therefore the effective length is taken as $0.7L$. It is important to recognise that rotational restraint is provided by the members connected to the beam and is also reliant upon the stiffness of the connections to transmit this restraint.

To design a column, it is necessary to determine the length over which it can buckle, termed the segment length. The length over which a strut can buckle is the length in any plane between restrained points in that plane. This is the distance between the intersections of the column and the restraining members and will usually be the storey height in a building frame. The restraining members will inhibit movement and/or rotation at the specific location. From the segment length, the effective length may be determined using Table 22 of BS 5950-1.

If the beams are attached to the columns using flexible connections, such as fin plates, then it would be unwise to assume any rotational restraint, whatever the stiffness of the beam. With connections such as partial depth end plates or double angle cleats, provided that the beams are reasonably sized, partial restraint may be assumed. Stiff beams connected to the columns using substantial connections such as flush or extended end plates will provide effective rotational restraint. However the above is general advice based upon normal circumstances and the engineer must view each case on its merits.

8.3 Strut Curves

The interaction of yielding and instability effects is influenced by a number of parameters including the section shape, the axis of bending, the initial out of straightness and the residual stresses within the section. Considerable research has shown that the effect of these parameters may be efficiently incorporated by simply using the appropriate strut curve from a family of four (tabulated in BS 5950-1 in Table 24 as curves a, b, c and d).

8.4 Strut Slenderness and Axial Capacity

Once the appropriate strut curve has been selected, the value of the compressive strength p_c is obtained from Table 24 of BS 5950-1 using input parameters of slenderness and the material design strength p_y . The slenderness λ of the strut is calculated as the effective length divided by the radius of gyration of the column section about the appropriate axis, ie $\lambda = L_E / r$. For values of λ below 15, p_c may be taken as the yield strength P_y of the material. Provided that the strut section is Class 1, 2 or 3, the compression resistance P_c of the strut is given by Clause 4.7.4 as:

$$P_c = A_g p_c$$

where:

A_g is the gross cross section area of the section

p_c is the compressive strength determined from its slenderness.

8.5 Columns in Simple Construction

In non-sway frames using simple construction, joints are designed to be flexible. The distribution of forces and moments in the frame are determined assuming that the connections between beams and columns are pinned. The joint flexibility may include distortions, which arise as a consequence of plastic deformations in all components of the connections except the bolts. The beams are designed on the basis of being simply supported at their ends. A beam of span L measured between the column centre-lines and

subjected to uniformly distributed loading w , will be designed for a maximum moment of $w L^2/8$. In reality the beams are not supported on the column centre-lines and thus some eccentricity will occur, leading to moments in the columns. A nominal eccentricity is therefore assumed when designing columns in simple construction.

BS 5950-1, Clause 4.7.7 presents a well-established approach to the design of such columns.

8.6 Compression Members with Moments

Compression members with moments are designed using a more comprehensive interaction formulation, as given in Clause 4.8.3.3 of BS 5950-1. Two separate expressions are needed, the first to deal primarily with in-plane buckling, the second to deal with out-of-plane buckling.

Bending Moment and Deflection Formulae for Beams

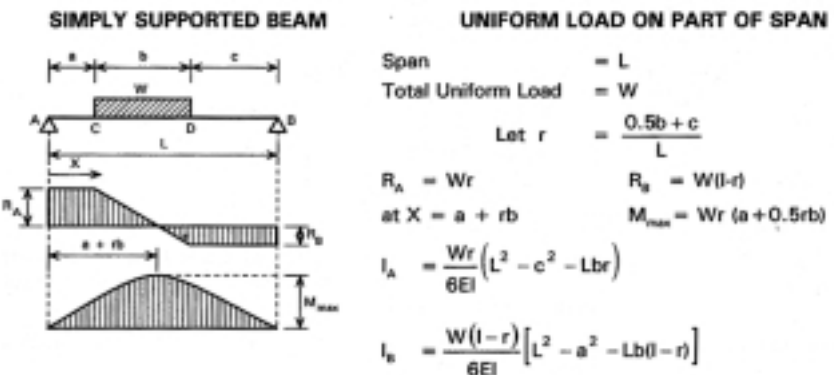
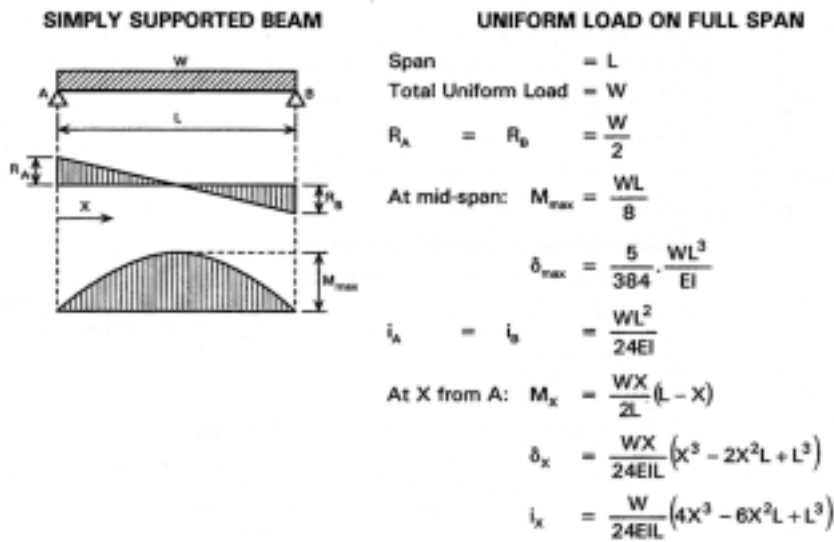

Equation to elastic line between C and D, i.e. $a \leq X \leq a + b$

$$\delta_x = -\frac{W}{24Eib} \left[X^4 - 4(a+rb)X^3 + 6a^2X^2 + 4 \left\{ rb \left(L^2 - c^2 - cb - \frac{b^2}{2} \right) - a^3 \right\} X + a^4 \right]$$

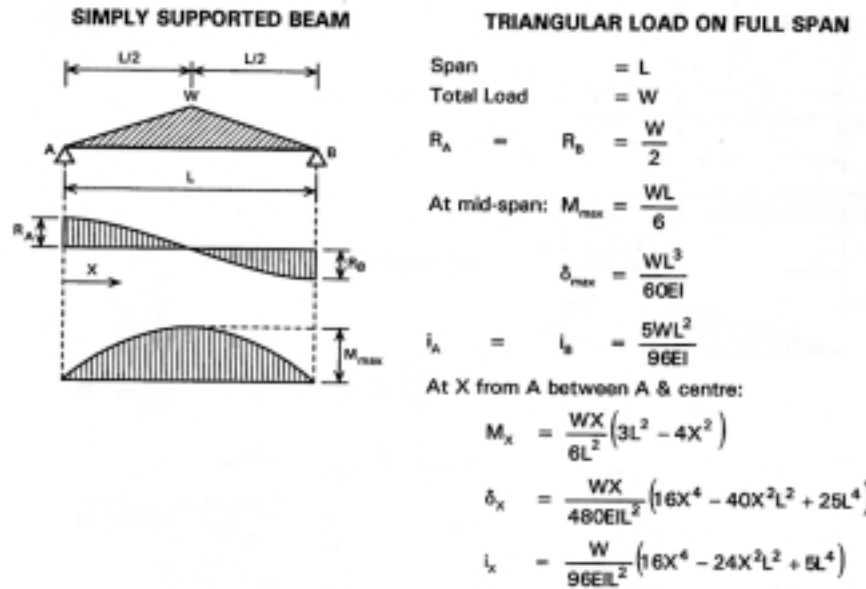

Bending Moment and Deflection Formulae for Beams

SIMPLY SUPPORTED BEAM

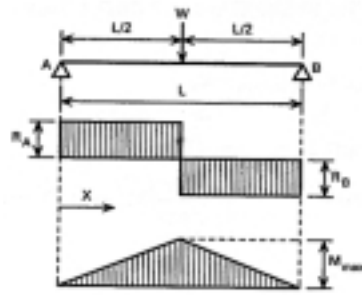

POINT LOAD AT MID-SPAN

Span = L
 Point Load = W
 $R_A = R_B = \frac{W}{2}$
 at mid-span: $M_{max} = \frac{WL}{4}$
 $\delta_{max} = \frac{1}{48} \frac{WL^3}{EI}$
 $i_A = i_B = \frac{WL^2}{16EI}$
 at X from A between A & centre:
 $M_x = \frac{WX}{2}$
 $\delta_x = \frac{WX}{48EI} (3L^2 - 4X^2)$
 $i_x = \frac{W}{16EI} (L^2 - 4X^2)$

SIMPLY SUPPORTED BEAM

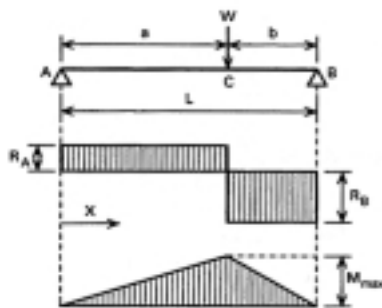

POINT LOAD AT ANY POSITION

Span = L
 Point Load = W
 $R_A = \frac{Wb}{L}$
 $R_B = \frac{Wa}{L}$
 at C under load: $M_{max} = \frac{Wab}{L}$
 $\delta_C = \frac{Wa^2b^2}{3EIL}$
 $i_A = \frac{Wab}{6EIL} (L+b)$ $i_B = \frac{Wab}{6EIL} (L+a)$
 When $a > b$, δ_{max} is at X from A:
 $\delta_{max} = \frac{Wab(L+b)}{27EIL} \sqrt{3a(L+b)}$
 $X = \sqrt{\frac{a(L+b)}{3}}$

SIMPLY SUPPORTED BEAM

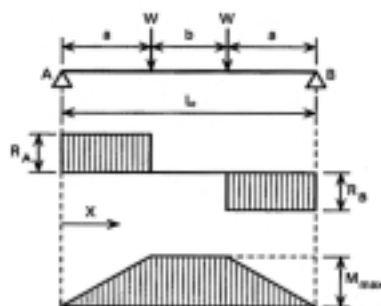

TWO EQUAL SYMMETRICAL POINT LOADS

Span = L
 Two Point Loads each = W
 $R_A = R_B = W$
 M_{max} over length $b = Wa$
 δ_{max} at mid-span = $\frac{Wa}{24EI} (3L^2 - 4a^2)$
 δ under either load = $\frac{Wa^2}{6EI} (3L - 4a)$;
 $i_A = i_B = \frac{Wa}{2EI} (L - a)$
 If $a = b = \frac{L}{3}$, $\delta_{max} = \frac{23}{648} \frac{WL^3}{EI}$

Bending Moment and Deflection Formulae for Beams

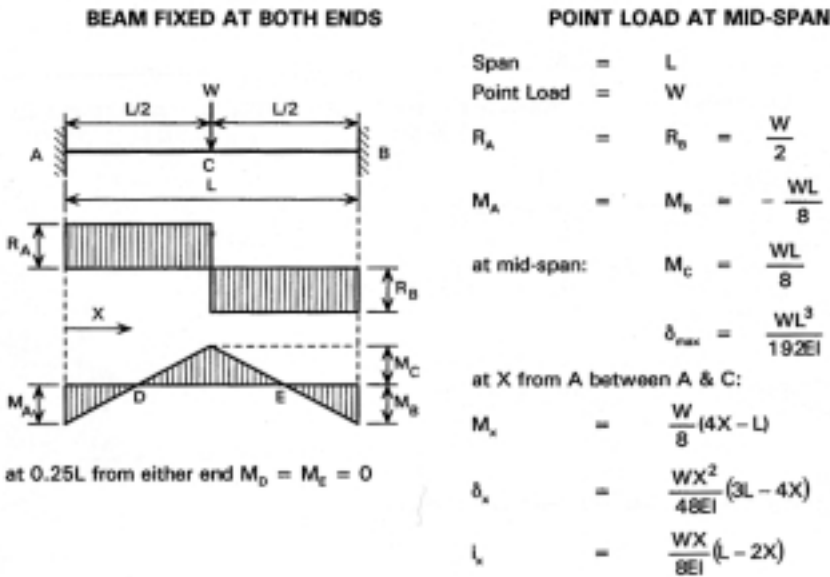
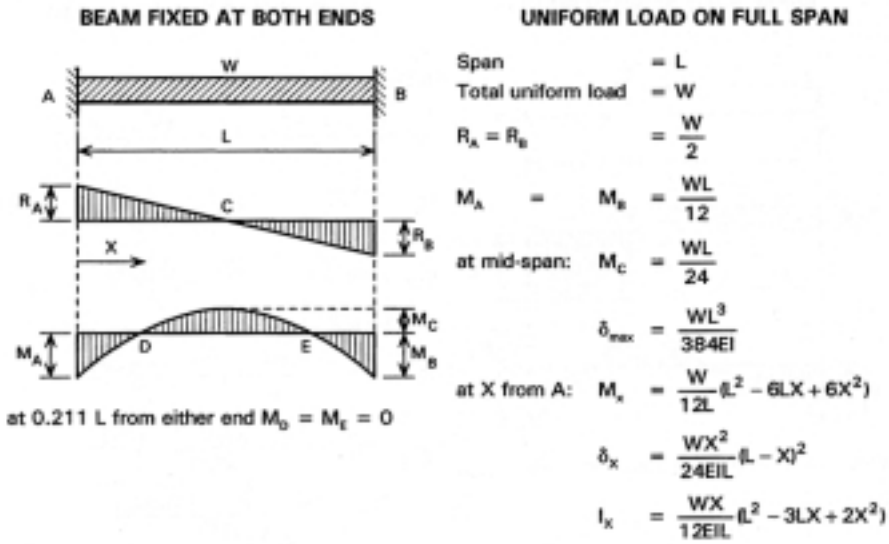

METRIC CONVERSIONS

Basic conversion factors

The following equivalents of SI units are given in imperial and, where applicable, metric technical units.

1mm	= 0.03937 in	1in	= 25.4 mm	1 hect.	= 2.471 acres	1 acre	= 0.405 hect
1m	= 3.281 ft	1ft	= 0.3048 m	1mm ³	= 0.00006102 in ³	1in ³	= 16.390 mm ³
	= 1.094 yd	1yd	= 0.9144 m	1m ³	= 35.31 ft ³	1ft ³	= 0.02832 m ³
1km	= 0.6214 mile	1 mile	= 1.609 km		= 1.308 yd ³	1yd ³	= 0.7646 m ³
1mm ²	= 0.00155 in ²	1in ²	= 645.2 mm ²	1mm ⁴	= 0.00002403 in ⁴	1in ⁴	= 416,200 mm ⁴
1m ²	= 10.76 ft ²	1ft ²	= 0.0929 m ²				
1m ²	= 1.196 yd ²	1yd ²	= 0.8361 m ²				

Force

1 N	= 0.2248 lbf	= 0.1020 kgf	1 kN	= 0.1004 tonf	= 102.0 kgf	= 0.1020 tonf
4.448 N	= 1 lbf	= 0.4536 kgf	9.964 kN	= 1 tonf	= 1,16 kgf	= 1016 tonf
9.807 N	= 2.205 lbf	= 1 kgf	9.807 kN	= 0.9842 tonf	= 1,000 kgf	= 1 tonf

Force per unit length

1 N/m	= 0.06852 lbf/ft	= 0.1020 kgf/m	1 kN/m	= 0.0306 tonf/ft	= 0.1020 tonf/m
14.59 N/m	= 1 lbf/ft	= 1.488 kgf/m	32.69 kN/m	= 1 ton/ft	= 3.33 tonne f/m
9.807 N/m	= 0.672 lbf/ft	= 1 kgf/m	9.807 kN/m	= 0.3000 tonf/ft	= 1 tonf/m

Force per unit area

1 N/mm ²	= 145 lbf/in ²	= 10.20 kgf/cm ²	1 N/mm ²	= 0.0648 tonf/in ²	= 10.2 kgf/cm ²
0.0069 N/mm ²	= 1 lbf/in ²	= 0.070kgf/cm ²	15.44 N/mm ²	= 1 tonf/in ²	= 157.5 kgf/cm ²
0.0981 N/mm ²	= 14.22lbf/in ²	= 1kgf/cm ²	0.0981 N/mm ²	= 0.00635 tonf/in ²	= 1 kgf/cm ²
1 N/m ²	= 0.0210 lbf/ft ²	= 0.102 kgf/m ²	1 N/mm ²	= 9.32 tonf/ft ²	= 10.2 kgf/cm ²
47.88 N/m ²	= 1 lbf/ft ²	= 4.882 kgf/m ²	0.1073 N/mm ²	= 1 tonf/ft ²	= 1.094 kgf/cm ²
9.807 N/m ²	= 0.2048 lbf/ft ²	= 1kgf/m ²	0.0981 N/mm ²	= 0.914 tonf/ft ²	= 1kgf/cm ²

Force per unit volume

1 N/m ³	= 0.00637 lbf/ft ³	= 0.102 kgf/m ³	1 kN/m ³	= 0.00284 tonf/ft ³	= 0.102 tonf/m ³
157.1 N/m ³	= 1lbf/ft ³	= 16.02 kgf/m ³	351.9 kN/m ³	= 1 tonf/ft ³	= 35.88 tonf/m ³
9.807 N/m ³	= 0.0624 lbf/ft ³	= 1 kgf/m ³	9.807 kN/m ³	= 0.0279 tonf/ft ³	= 1 tonf/m ³
1 kN/m ³	= 0.0037 lbf/in ³	= 0.102 tonf/m ³			
271 kN/m ³	= 1 lbf/in ³	= 27.68 tonf/m ³			
9.81 kN/m ³	= 0.0362 lbf/in ³	= 1 tonf/m ³			

Moment

1 N-m	= 8.851 lbf-in	= 0.7376 lbf-ft	= 0.1020 kgf-m
0.1130 N-m	= 1 lbf-in	= 0.08333 lbf-ft	= 0.01152 kgf-m
1.356 N-m	= 12 lbf-in	= 1 lbf-ft	= 0.1383 kgf-m
9.807 N-m	= 86.80 lbf-in	= 7.233 lbf-ft	= 1 kgf-m

Fluid capacity

1 litre	= 0.22 imperial gallons	= 0.2642 USA gallons
4.564 litres	= 1 imperial gallon	= 1.201 USA gallons
3.785 litres	= 0.8327 imperial gallons	= 1 USA gallon

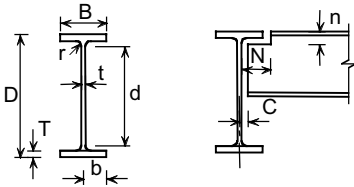

Section Designation	Mass per Metre kg/m	Depth of Section D mm	Width of Section B mm	Thickness		Root Radius r mm	Depth between Fillets d mm	Ratios for Local Buckling		Dimensions for Detailing			Surface Area	
				Web t mm	Flange T mm			Flange b/T	Web d/t	End Clearance C mm	Notch		Per Metre m ²	Per Tonne m ²
											N mm	n mm		
1016x305x487 # +	486.6	1036.1	308.5	30.0	54.1	30.0	867.9	2.85	28.9	17	150	86	3.19	6.57
1016x305x437 # +	436.9	1025.9	305.4	26.9	49.0	30.0	867.9	3.12	32.3	16	150	80	3.17	7.25
1016x305x393 # +	392.7	1016.0	303.0	24.4	43.9	30.0	868.2	3.45	35.6	14	150	74	3.14	8.01
1016x305x349 # +	349.4	1008.1	302.0	21.1	40.0	30.0	868.1	3.77	41.1	13	150	70	3.13	8.96
1016x305x314 # +	314.3	1000.0	300.0	19.1	35.9	30.0	868.2	4.18	45.5	12	150	66	3.11	9.90
1016x305x272 # +	272.3	990.1	300.0	16.5	31.0	30.0	868.1	4.84	52.6	10	152	63	3.10	11.4
1016x305x249 # +	248.7	980.2	300.0	16.5	26.0	30.0	868.2	5.77	52.6	10	152	56	3.08	12.4
1016x305x222 # +	222.0	970.3	300.0	16.0	21.1	30.0	868.1	7.11	54.3	10	152	52	3.06	13.8
914 x 419 x 388 #	388.0	921.0	420.5	21.4	36.6	24.1	799.6	5.74	37.4	13	210	62	3.44	8.87
914 x 419 x 343 #	343.3	911.8	418.5	19.4	32.0	24.1	799.6	6.54	41.2	12	210	58	3.42	9.95
914 x 305 x 289 #	289.1	926.6	307.7	19.5	32.0	19.1	824.4	4.81	42.3	12	156	52	3.01	10.4
914 x 305 x 253 #	253.4	918.4	305.5	17.3	27.9	19.1	824.4	5.47	47.7	11	156	48	2.99	11.8
914 x 305 x 224 #	224.2	910.4	304.1	15.9	23.9	19.1	824.4	6.36	51.8	10	156	44	2.97	13.3
914 x 305 x 201 #	200.9	903.0	303.3	15.1	20.2	19.1	824.4	7.51	54.6	10	156	40	2.96	14.7
838 x 292 x 226 #	226.5	850.9	293.8	16.1	26.8	17.8	761.7	5.48	47.3	10	150	46	2.81	12.4
838 x 292 x 194 #	193.8	840.7	292.4	14.7	21.7	17.8	761.7	6.74	51.8	9	150	40	2.79	14.4
838 x 292 x 176 #	175.9	834.9	291.7	14.0	18.8	17.8	761.7	7.76	54.4	9	150	38	2.78	15.8
762 x 267 x 197	196.8	769.8	268.0	15.6	25.4	16.5	686.0	5.28	44.0	10	138	42	2.55	13.0
762 x 267 x 173	173.0	762.2	266.7	14.3	21.6	16.5	686.0	6.17	48.0	9	138	40	2.53	14.6
762 x 267 x 147	146.9	754.0	265.2	12.8	17.5	16.5	686.0	7.58	53.6	8	138	34	2.51	17.1
762 x 267 x 134	133.9	750.0	264.4	12.0	15.5	16.5	686.0	8.53	57.2	8	138	32	2.51	18.7
686 x 254 x 170	170.2	692.9	255.8	14.5	23.7	15.2	615.1	5.40	42.4	9	132	40	2.35	13.8
686 x 254 x 152	152.4	687.5	254.5	13.2	21.0	15.2	615.1	6.06	46.6	9	132	38	2.34	15.4
686 x 254 x 140	140.1	683.5	253.7	12.4	19.0	15.2	615.1	6.68	49.6	8	132	36	2.33	16.6
686 x 254 x 125	125.2	677.9	253.0	11.7	16.2	15.2	615.1	7.81	52.6	8	132	32	2.32	18.5
610 x 305 x 238	238.1	635.8	311.4	18.4	31.4	16.5	540.0	4.96	29.3	11	158	48	2.45	10.3
610 x 305 x 179	179.0	620.2	307.1	14.1	23.6	16.5	540.0	6.51	38.3	9	158	42	2.41	13.5
610 x 305 x 149	149.2	612.4	304.8	11.8	19.7	16.5	540.0	7.74	45.8	8	158	38	2.39	16.0
610 x 229 x 140	139.9	617.2	230.2	13.1	22.1	12.7	547.6	5.21	41.8	9	120	36	2.11	15.1
610 x 229 x 125	125.1	612.2	229.0	11.9	19.6	12.7	547.6	5.84	46.0	8	120	34	2.09	16.7
610 x 229 x 113	113.0	607.6	228.2	11.1	17.3	12.7	547.6	6.60	49.3	8	120	30	2.08	18.4
610 x 229 x 101	101.2	602.6	227.6	10.5	14.8	12.7	547.6	7.69	52.2	7	120	28	2.07	20.5
533 x 210 x 122	122.0	544.5	211.9	12.7	21.3	12.7	476.5	4.97	37.5	8	110	34	1.89	15.5
533 x 210 x 109	109.0	539.5	210.8	11.6	18.8	12.7	476.5	5.61	41.1	8	110	32	1.88	17.2
533 x 210 x 101	101.0	536.7	210.0	10.8	17.4	12.7	476.5	6.03	44.1	7	110	32	1.87	18.5
533 x 210 x 92	92.1	533.1	209.3	10.1	15.6	12.7	476.5	6.71	47.2	7	110	30	1.86	20.2
533 x 210 x 82	82.2	528.3	208.8	9.6	13.2	12.7	476.5	7.91	49.6	7	110	26	1.85	22.5

+ Section is not given in BS 4-1: 1993.

Check availability.

For explanation of tables refer to the Handbook of Structural Steelwork - 3rd edition

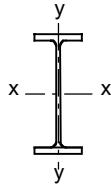

Section Designation	Second Moment of Area		Radius of Gyration		Elastic Modulus		Plastic Modulus		Buckling Parameter u	Torsional Index x	Warping Constant H dm6	Torsional Constant J cm4	Area of Section A cm2
	Axis x-x	Axis y-y	Axis x-x	Axis y-y	Axis x-x	Axis y-y	Axis x-x	Axis y-y					
	cm4	cm4	cm	cm	cm3	cm3	cm3	cm3					
1016x305x487 # +	1020000	26700	40.6	6.57	19700	1730	23200	2800	0.867	21.1	64.4	4300	620
1016x305x437 # +	910000	23500	40.4	6.49	17700	1540	20800	2470	0.868	23.1	55.9	3190	557
1016x305x393 # +	808000	20500	40.2	6.40	15900	1350	18500	2170	0.868	25.5	48.4	2330	500
1016x305x349 # +	723000	18500	40.3	6.44	14400	1220	16600	1940	0.872	27.9	43.3	1720	445
1016x305x314 # +	644000	16200	40.1	6.37	12900	1080	14900	1710	0.872	30.7	37.7	1260	400
1016x305x272 # +	554000	14000	40.0	6.35	11200	934	12800	1470	0.872	35.0	32.2	835	347
1016x305x249 # +	481000	11800	39.0	6.09	9820	784	11400	1250	0.861	39.9	26.8	582	317
1016x305x222 # +	408000	9550	38.0	5.81	8410	636	9810	1020	0.849	45.8	21.5	390	283
914 x 419 x 388 #	720000	45400	38.2	9.59	15600	2160	17700	3340	0.885	26.7	88.9	1730	494
914 x 419 x 343 #	626000	39200	37.8	9.46	13700	1870	15500	2890	0.883	30.1	75.8	1190	437
914 x 305 x 289 #	504000	15600	37.0	6.51	10900	1010	12600	1600	0.867	31.9	31.2	926	368
914 x 305 x 253 #	436000	13300	36.8	6.42	9500	871	10900	1370	0.865	36.2	26.4	626	323
914 x 305 x 224 #	376000	11200	36.3	6.27	8270	739	9540	1160	0.861	41.3	22.1	422	286
914 x 305 x 201 #	325000	9420	35.7	6.07	7200	621	8350	982	0.853	46.9	18.4	291	256
838 x 292 x 226 #	340000	11400	34.3	6.27	7990	773	9160	1210	0.869	35.0	19.3	514	289
838 x 292 x 194 #	279000	9070	33.6	6.06	6640	620	7640	974	0.862	41.6	15.2	306	247
838 x 292 x 176 #	246000	7800	33.1	5.90	5890	535	6810	842	0.856	46.5	13.0	221	224
762 x 267 x 197	240000	8180	30.9	5.71	6230	610	7170	959	0.868	33.2	11.3	404	251
762 x 267 x 173	205000	6850	30.5	5.58	5390	514	6200	807	0.865	38.1	9.39	267	220
762 x 267 x 147	169000	5460	30.0	5.40	4470	411	5160	647	0.858	45.2	7.40	159	187
762 x 267 x 134	151000	4790	29.7	5.30	4020	362	4640	570	0.853	49.8	6.46	119	171
686 x 254 x 170	170000	6630	28.0	5.53	4920	518	5630	811	0.872	31.8	7.42	308	217
686 x 254 x 152	150000	5780	27.8	5.46	4370	455	5000	710	0.871	35.4	6.42	220	194
686 x 254 x 140	136000	5180	27.6	5.39	3990	409	4560	638	0.869	38.6	5.72	169	178
686 x 254 x 125	118000	4380	27.2	5.24	3480	346	3990	542	0.863	43.8	4.80	116	159
610 x 305 x 238	210000	15800	26.3	7.23	6590	1020	7490	1570	0.887	21.3	14.5	785	303
610 x 305 x 179	153000	11400	25.9	7.07	4940	743	5550	1140	0.886	27.7	10.2	340	228
610 x 305 x 149	126000	9310	25.7	7.00	4110	611	4590	937	0.886	32.7	8.17	200	190
610 x 229 x 140	112000	4510	25.0	5.03	3620	391	4140	611	0.875	30.6	3.99	216	178
610 x 229 x 125	98600	3930	24.9	4.97	3220	343	3680	535	0.874	34.1	3.45	154	159
610 x 229 x 113	87300	3430	24.6	4.88	2870	301	3280	469	0.870	38.1	2.99	111	144
610 x 229 x 101	75800	2920	24.2	4.75	2520	256	2880	400	0.863	43.1	2.52	77.0	129
533 x 210 x 122	76000	3390	22.1	4.67	2790	320	3200	500	0.878	27.6	2.32	178	155
533 x 210 x 109	66800	2940	21.9	4.60	2480	279	2830	436	0.874	31.0	1.99	126	139
533 x 210 x 101	61500	2690	21.9	4.57	2290	256	2610	399	0.873	33.2	1.81	101	129
533 x 210 x 92	55200	2390	21.7	4.51	2070	228	2360	356	0.873	36.4	1.60	75.7	117
533 x 210 x 82	47500	2010	21.3	4.38	1800	192	2060	300	0.863	41.6	1.33	51.5	105

+ Section is not given in BS 4-1: 1993.

Check availability.

For explanation of tables refer to the Handbook of Structural Steelwork - 3rd edition

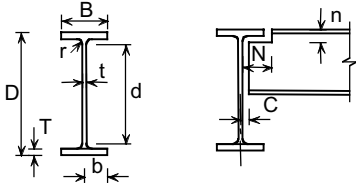

Section Designation	Mass per Metre kg/m	Depth of Section D mm	Width of Section B mm	Thickness		Root Radius r mm	Depth between Fillets d mm	Ratios for Local Buckling		Dimensions for Detailing			Surface Area	
				Web t mm	Flange T mm			Flange b/T	Web d/t	End Clearance C mm	Notch		Per Metre m ²	Per Tonne m ²
											N Mm	n mm		
457 x 191 x 98	98.3	467.2	192.8	11.4	19.6	10.2	407.6	4.92	35.8	8	102	30	1.67	16.9
457 x 191 x 89	89.3	463.4	191.9	10.5	17.7	10.2	407.6	5.42	38.8	7	102	28	1.66	18.5
457 x 191 x 82	82.0	460.0	191.3	9.9	16.0	10.2	407.6	5.98	41.2	7	102	28	1.65	20.1
457 x 191 x 74	74.3	457.0	190.4	9.0	14.5	10.2	407.6	6.57	45.3	7	102	26	1.64	22.1
457 x 191 x 67	67.1	453.4	189.9	8.5	12.7	10.2	407.6	7.48	48.0	6	102	24	1.63	24.3
457 x 152 x 82	82.1	465.8	155.3	10.5	18.9	10.2	407.6	4.11	38.8	7	84	30	1.51	18.4
457 x 152 x 74	74.2	462.0	154.4	9.6	17.0	10.2	407.6	4.54	42.5	7	84	28	1.50	20.3
457 x 152 x 67	67.2	458.0	153.8	9.0	15.0	10.2	407.6	5.13	45.3	7	84	26	1.50	22.3
457 x 152 x 60	59.8	454.6	152.9	8.1	13.3	10.2	407.6	5.75	50.3	6	84	24	1.49	24.9
457 x 152 x 52	52.3	449.8	152.4	7.6	10.9	10.2	407.6	6.99	53.6	6	84	22	1.48	28.2
406 x 178 x 74	74.2	412.8	179.5	9.5	16.0	10.2	360.4	5.61	37.9	7	96	28	1.51	20.3
406 x 178 x 67	67.1	409.4	178.8	8.8	14.3	10.2	360.4	6.25	41.0	6	96	26	1.50	22.3
406 x 178 x 60	60.1	406.4	177.9	7.9	12.8	10.2	360.4	6.95	45.6	6	96	24	1.49	24.8
406 x 178 x 54	54.1	402.6	177.7	7.7	10.9	10.2	360.4	8.15	46.8	6	96	22	1.48	27.4
406 x 140 x 46	46.0	403.2	142.2	6.8	11.2	10.2	360.4	6.35	53.0	5	78	22	1.34	29.2
406 x 140 x 39	39.0	398.0	141.8	6.4	8.6	10.2	360.4	8.24	56.3	5	78	20	1.33	34.2
356 x 171 x 67	67.1	363.4	173.2	9.1	15.7	10.2	311.6	5.52	34.2	7	94	26	1.38	20.6
356 x 171 x 57	57.0	358.0	172.2	8.1	13.0	10.2	311.6	6.62	38.5	6	94	24	1.37	24.1
356 x 171 x 51	51.0	355.0	171.5	7.4	11.5	10.2	311.6	7.46	42.1	6	94	22	1.36	26.7
356 x 171 x 45	45.0	351.4	171.1	7.0	9.7	10.2	311.6	8.82	44.5	6	94	20	1.36	30.1
356 x 127 x 39	39.1	353.4	126.0	6.6	10.7	10.2	311.6	5.89	47.2	5	70	22	1.18	30.2
356 x 127 x 33	33.1	349.0	125.4	6.0	8.5	10.2	311.6	7.38	51.9	5	70	20	1.17	35.4
305 x 165 x 54	54.0	310.4	166.9	7.9	13.7	8.9	265.2	6.09	33.6	6	90	24	1.26	23.3
305 x 165 x 46	46.1	306.6	165.7	6.7	11.8	8.9	265.2	7.02	39.6	5	90	22	1.25	27.1
305 x 165 x 40	40.3	303.4	165.0	6.0	10.2	8.9	265.2	8.09	44.2	5	90	20	1.24	30.8
305 x 127 x 48	48.1	311.0	125.3	9.0	14.0	8.9	265.2	4.47	29.5	7	70	24	1.09	22.7
305 x 127 x 42	41.9	307.2	124.3	8.0	12.1	8.9	265.2	5.14	33.1	6	70	22	1.08	25.8
305 x 127 x 37	37.0	304.4	123.4	7.1	10.7	8.9	265.2	5.77	37.4	6	70	20	1.07	29.0
305 x 102 x 33	32.8	312.7	102.4	6.6	10.8	7.6	275.9	4.74	41.8	5	58	20	1.01	30.8
305 x 102 x 28	28.2	308.7	101.8	6.0	8.8	7.6	275.9	5.78	46.0	5	58	18	1.00	35.4
305 x 102 x 25	24.8	305.1	101.6	5.8	7.0	7.6	275.9	7.26	47.6	5	58	16	0.992	40.0
254 x 146 x 43	43.0	259.6	147.3	7.2	12.7	7.6	219.0	5.80	30.4	6	82	22	1.08	25.1
254 x 146 x 37	37.0	256.0	146.4	6.3	10.9	7.6	219.0	6.72	34.8	5	82	20	1.07	29.0
254 x 146 x 31	31.1	251.4	146.1	6.0	8.6	7.6	219.0	8.49	36.5	5	82	18	1.06	34.2
254 x 102 x 28	28.3	260.4	102.2	6.3	10.0	7.6	225.2	5.11	35.7	5	58	18	0.904	31.9
254 x 102 x 25	25.2	257.2	101.9	6.0	8.4	7.6	225.2	6.07	37.5	5	58	16	0.897	35.6
254 x 102 x 22	22.0	254.0	101.6	5.7	6.8	7.6	225.2	7.47	39.5	5	58	16	0.890	40.5
203 x 133 x 30	30.0	206.8	133.9	6.4	9.6	7.6	172.4	6.97	26.9	5	74	18	0.923	30.8
203 x 133 x 25	25.1	203.2	133.2	5.7	7.8	7.6	172.4	8.54	30.2	5	74	16	0.915	36.4
203 x 102 x 23	23.1	203.2	101.8	5.4	9.3	7.6	169.4	5.47	31.4	5	60	18	0.790	34.2
178 x 102 x 19	19.0	177.8	101.2	4.8	7.9	7.6	146.8	6.41	30.6	4	60	16	0.738	38.8
152 x 89 x 16	16.0	152.4	88.7	4.5	7.7	7.6	121.8	5.76	27.1	4	54	16	0.638	39.8
127 x 76 x 13	13.0	127.0	76.0	4.0	7.6	7.6	96.6	5.00	24.1	4	46	16	0.537	41.3

For explanation of tables refer to the Handbook of Structural Steelwork - 3rd edition

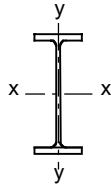

Section Designation	Second Moment of Area		Radius of Gyration		Elastic Modulus		Plastic Modulus		Buckling Parameter u	Torsional Index x	Warping Constant H dm ⁶	Torsional Constant J cm ⁴	Area of Section A cm ²
	Axis x-x	Axis y-y	Axis x-x	Axis y-y	Axis x-x	Axis y-y	Axis x-x	Axis y-y					
	cm ⁴	cm ⁴	cm	cm	cm ³	cm ³	cm ³	cm ³					
457 x 191 x 98	45700	2350	19.1	4.33	1960	243	2230	379	0.882	25.7	1.18	121	125
457 x 191 x 89	41000	2090	19.0	4.29	1770	218	2010	338	0.879	28.3	1.04	90.7	114
457 x 191 x 82	37100	1870	18.8	4.23	1610	196	1830	304	0.879	30.8	0.922	69.2	104
457 x 191 x 74	33300	1670	18.8	4.20	1460	176	1650	272	0.877	33.8	0.818	51.8	94.6
457 x 191 x 67	29400	1450	18.5	4.12	1300	153	1470	237	0.872	37.9	0.705	37.1	85.5
457 x 152 x 82	36600	1190	18.7	3.37	1570	153	1810	240	0.871	27.4	0.591	89.2	105
457 x 152 x 74	32700	1050	18.6	3.33	1410	136	1630	213	0.873	30.2	0.518	65.9	94.5
457 x 152 x 67	28900	913	18.4	3.27	1260	119	1450	187	0.868	33.6	0.448	47.7	85.6
457 x 152 x 60	25500	795	18.3	3.23	1120	104	1290	163	0.868	37.5	0.387	33.8	76.2
457 x 152 x 52	21400	645	17.9	3.11	950	84.6	1100	133	0.859	43.8	0.311	21.4	66.6
406 x 178 x 74	27300	1550	17.0	4.04	1320	172	1500	267	0.882	27.6	0.608	62.8	94.5
406 x 178 x 67	24300	1370	16.9	3.99	1190	153	1350	237	0.880	30.5	0.533	46.1	85.5
406 x 178 x 60	21600	1200	16.8	3.97	1060	135	1200	209	0.880	33.8	0.466	33.3	76.5
406 x 178 x 54	18700	1020	16.5	3.85	930	115	1060	178	0.871	38.3	0.392	23.1	69.0
406 x 140 x 46	15700	538	16.4	3.03	778	75.7	888	118	0.872	39.0	0.207	19.0	58.6
406 x 140 x 39	12500	410	15.9	2.87	629	57.8	724	90.8	0.858	47.5	0.155	10.7	49.7
356 x 171 x 67	19500	1360	15.1	3.99	1070	157	1210	243	0.886	24.4	0.412	55.7	85.5
356 x 171 x 57	16000	1110	14.9	3.91	896	129	1010	199	0.882	28.8	0.330	33.4	72.6
356 x 171 x 51	14100	968	14.8	3.86	796	113	896	174	0.881	32.1	0.286	23.8	64.9
356 x 171 x 45	12100	811	14.5	3.76	687	94.8	775	147	0.874	36.8	0.237	15.8	57.3
356 x 127 x 39	10200	358	14.3	2.68	576	56.8	659	89.1	0.871	35.2	0.105	15.1	49.8
356 x 127 x 33	8250	280	14.0	2.58	473	44.7	543	70.3	0.863	42.2	0.081	8.79	42.1
305 x 165 x 54	11700	1060	13.0	3.93	754	127	846	196	0.889	23.6	0.234	34.8	68.8
305 x 165 x 46	9900	896	13.0	3.90	646	108	720	166	0.891	27.1	0.195	22.2	58.7
305 x 165 x 40	8500	764	12.9	3.86	560	92.6	623	142	0.889	31.0	0.164	14.7	51.3
305 x 127 x 48	9580	461	12.5	2.74	616	73.6	711	116	0.874	23.3	0.102	31.8	61.2
305 x 127 x 42	8200	389	12.4	2.70	534	62.6	614	98.4	0.872	26.6	0.0846	21.1	53.4
305 x 127 x 37	7170	336	12.3	2.67	471	54.5	539	85.4	0.871	29.7	0.0725	14.8	47.2
305 x 102 x 33	6500	194	12.5	2.15	416	37.9	481	60.0	0.867	31.6	0.0442	12.2	41.8
305 x 102 x 28	5370	155	12.2	2.08	348	30.5	403	48.5	0.859	37.4	0.0349	7.40	35.9
305 x 102 x 25	4460	123	11.9	1.97	292	24.2	342	38.8	0.846	43.4	0.0273	4.77	31.6
254 x 146 x 43	6540	677	10.9	3.52	504	92.0	566	141	0.890	21.2	0.103	23.9	54.8
254 x 146 x 37	5540	571	10.8	3.48	433	78.0	483	119	0.889	24.4	0.0857	15.3	47.2
254 x 146 x 31	4410	448	10.5	3.36	351	61.3	393	94.1	0.879	29.6	0.0660	8.55	39.7
254 x 102 x 28	4010	179	10.5	2.22	308	34.9	353	54.8	0.874	27.5	0.0280	9.57	36.1
254 x 102 x 25	3420	149	10.3	2.15	266	29.2	306	46.0	0.867	31.4	0.0230	6.42	32.0
254 x 102 x 22	2840	119	10.1	2.06	224	23.5	259	37.3	0.856	36.3	0.0182	4.15	28.0
203 x 133 x 30	2900	385	8.71	3.17	280	57.5	314	88.2	0.881	21.5	0.0374	10.3	38.2
203 x 133 x 25	2340	308	8.56	3.10	230	46.2	258	70.9	0.877	25.6	0.0294	5.96	32.0
203 x 102 x 23	2110	164	8.46	2.36	207	32.2	234	49.8	0.888	22.5	0.0154	7.02	29.4
178 x 102 x 19	1360	137	7.48	2.37	153	27.0	171	41.6	0.886	22.6	0.00987	4.41	24.3
152 x 89 x 16	834	89.8	6.41	2.10	109	20.2	123	31.2	0.889	19.6	0.00470	3.56	20.3
127 x 76 x 13	473	55.7	5.35	1.84	74.6	14.7	84.2	22.6	0.896	16.3	0.00199	2.85	16.5

For explanation of tables refer to the Handbook of Structural Steelwork - 3rd edition

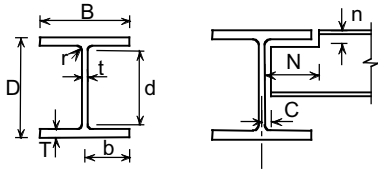

Section Designation	Mass per Metre kg/m	Depth of Section D mm	Width of Section B mm	Thickness		Root Radius r mm	Depth between Fillets d mm	Ratios for Local Buckling		Dimensions for Detailing			Surface Area	
				Web t mm	Flange T mm			Flange b/T	Web d/t	End Clearance C mm	Notch		Per Metre m ²	Per Tonne m ²
											N mm	n mm		
356 x 406 x 634 #	633.9	474.6	424.0	47.6	77.0	15.2	290.2	2.75	6.10	26	200	94	2.52	3.98
356 x 406 x 551 #	551.0	455.6	418.5	42.1	67.5	15.2	290.2	3.10	6.89	23	200	84	2.47	4.49
356 x 406 x 467 #	467.0	436.6	412.2	35.8	58.0	15.2	290.2	3.55	8.11	20	200	74	2.42	5.19
356 x 406 x 393 #	393.0	419.0	407.0	30.6	49.2	15.2	290.2	4.14	9.48	17	200	66	2.38	6.05
356 x 406 x 340 #	339.9	406.4	403.0	26.6	42.9	15.2	290.2	4.70	10.9	15	200	60	2.35	6.90
356 x 406 x 287 #	287.1	393.6	399.0	22.6	36.5	15.2	290.2	5.47	12.8	13	200	52	2.31	8.05
356 x 406 x 235 #	235.1	381.0	394.8	18.4	30.2	15.2	290.2	6.54	15.8	11	200	46	2.28	9.69
356 x 368 x 202 #	201.9	374.6	374.7	16.5	27.0	15.2	290.2	6.94	17.6	10	190	44	2.19	10.8
356 x 368 x 177 #	177.0	368.2	372.6	14.4	23.8	15.2	290.2	7.83	20.2	9	190	40	2.17	12.3
356 x 368 x 153 #	152.9	362.0	370.5	12.3	20.7	15.2	290.2	8.95	23.6	8	190	36	2.16	14.1
356 x 368 x 129 #	129.0	355.6	368.6	10.4	17.5	15.2	290.2	10.50	27.9	7	190	34	2.14	16.6
305 x 305 x 283	282.9	365.3	322.2	26.8	44.1	15.2	246.7	3.65	9.21	15	158	60	1.94	6.86
305 x 305 x 240	240.0	352.5	318.4	23.0	37.7	15.2	246.7	4.22	10.7	14	158	54	1.91	7.94
305 x 305 x 198	198.1	339.9	314.5	19.1	31.4	15.2	246.7	5.01	12.9	12	158	48	1.87	9.46
305 x 305 x 158	158.1	327.1	311.2	15.8	25.0	15.2	246.7	6.22	15.6	10	158	42	1.84	11.6
305 x 305 x 137	136.9	320.5	309.2	13.8	21.7	15.2	246.7	7.12	17.9	9	158	38	1.82	13.3
305 x 305 x 118	117.9	314.5	307.4	12.0	18.7	15.2	246.7	8.22	20.6	8	158	34	1.81	15.3
305 x 305 x 97	96.9	307.9	305.3	9.9	15.4	15.2	246.7	9.91	24.9	7	158	32	1.79	18.5
254 x 254 x 167	167.1	289.1	265.2	19.2	31.7	12.7	200.3	4.18	10.4	12	134	46	1.58	9.45
254 x 254 x 132	132.0	276.3	261.3	15.3	25.3	12.7	200.3	5.16	13.1	10	134	38	1.55	11.7
254 x 254 x 107	107.1	266.7	258.8	12.8	20.5	12.7	200.3	6.31	15.6	8	134	34	1.52	14.2
254 x 254 x 89	88.9	260.3	256.3	10.3	17.3	12.7	200.3	7.41	19.4	7	134	30	1.50	16.9
254 x 254 x 73	73.1	254.1	254.6	8.6	14.2	12.7	200.3	8.96	23.3	6	134	28	1.49	20.4
203 x 203 x 86	86.1	222.2	209.1	12.7	20.5	10.2	160.8	5.10	12.7	8	110	32	1.24	14.4
203 x 203 x 71	71.0	215.8	206.4	10.0	17.3	10.2	160.8	5.97	16.1	7	110	28	1.22	17.2
203 x 203 x 60	60.0	209.6	205.8	9.4	14.2	10.2	160.8	7.25	17.1	7	110	26	1.21	20.1
203 x 203 x 52	52.0	206.2	204.3	7.9	12.5	10.2	160.8	8.17	20.4	6	110	24	1.20	23.0
203 x 203 x 46	46.1	203.2	203.6	7.2	11.0	10.2	160.8	9.25	22.3	6	110	22	1.19	25.8
152 x 152 x 37	37.0	161.8	154.4	8.0	11.5	7.6	123.6	6.71	15.5	6	84	20	0.912	24.7
152 x 152 x 30	30.0	157.6	152.9	6.5	9.4	7.6	123.6	8.13	19.0	5	84	18	0.901	30.0
152 x 152 x 23	23.0	152.4	152.2	5.8	6.8	7.6	123.6	11.2	21.3	5	84	16	0.889	38.7

Check availability.

For explanation of tables refer to the Handbook of Structural Steelwork - 3rd edition

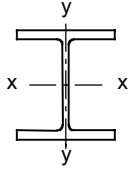

Section Designation	Second Moment of Area		Radius of Gyration		Elastic Modulus		Plastic Modulus		Buckling Parameter	Torsional Index	Warping Constant	Torsional Constant	Area of Section
	Axis x-x	Axis y-y	Axis x-x	Axis y-y	Axis x-x	Axis y-y	Axis x-x	Axis y-y					
	cm ⁴	cm ⁴	cm	cm	cm ³	cm ³	cm ³	cm ³	u	x	H dm ⁶	J cm ⁴	A cm ²
356 x 406 x 634 #	275000	98100	18.4	11.0	11600	4630	14200	7110	0.843	5.46	38.8	13700	808
356 x 406 x 551 #	227000	82700	18.0	10.9	9960	3950	12100	6060	0.841	6.05	31.1	9240	702
356 x 406 x 467 #	183000	67800	17.5	10.7	8380	3290	10000	5030	0.839	6.86	24.3	5810	595
356 x 406 x 393 #	147000	55400	17.1	10.5	7000	2720	8220	4150	0.837	7.87	18.9	3550	501
356 x 406 x 340 #	123000	46900	16.8	10.4	6030	2330	7000	3540	0.836	8.84	15.5	2340	433
356 x 406 x 287 #	99900	38700	16.5	10.3	5080	1940	5810	2950	0.834	10.2	12.3	1440	366
356 x 406 x 235 #	79100	31000	16.3	10.2	4150	1570	4690	2380	0.835	12.0	9.54	812	299
356 x 368 x 202 #	66300	23700	16.1	9.60	3540	1260	3970	1920	0.844	13.4	7.16	558	257
356 x 368 x 177 #	57100	20500	15.9	9.54	3100	1100	3460	1670	0.843	15.0	6.09	381	226
356 x 368 x 153 #	48600	17600	15.8	9.49	2680	948	2970	1440	0.844	17.0	5.11	251	195
356 x 368 x 129 #	40300	14600	15.6	9.43	2260	793	2480	1200	0.845	19.8	4.18	153	164
305 x 305 x 283	78900	24600	14.8	8.27	4320	1530	5110	2340	0.856	7.65	6.35	2030	360
305 x 305 x 240	64200	20300	14.5	8.15	3640	1280	4250	1950	0.854	8.74	5.03	1270	306
305 x 305 x 198	50900	16300	14.2	8.04	3000	1040	3440	1580	0.854	10.2	3.88	734	252
305 x 305 x 158	38800	12600	13.9	7.90	2370	808	2680	1230	0.852	12.5	2.87	378	201
305 x 305 x 137	32800	10700	13.7	7.83	2050	692	2300	1050	0.852	14.1	2.39	249	174
305 x 305 x 118	27700	9060	13.6	7.77	1760	589	1960	895	0.851	16.2	1.98	161	150
305 x 305 x 97	22300	7310	13.4	7.69	1450	479	1590	726	0.852	19.2	1.56	91.2	123
254 x 254 x 167	30000	9870	11.9	6.81	2080	744	2420	1140	0.851	8.50	1.63	626	213
254 x 254 x 132	22500	7530	11.6	6.69	1630	576	1870	878	0.850	10.3	1.19	319	168
254 x 254 x 107	17500	5930	11.3	6.59	1310	458	1480	697	0.849	12.4	0.898	172	136
254 x 254 x 89	14300	4860	11.2	6.55	1100	379	1220	575	0.851	14.5	0.717	102	113
254 x 254 x 73	11400	3910	11.1	6.48	898	307	992	465	0.849	17.3	0.562	57.6	93.1
203 x 203 x 86	9450	3130	9.28	5.34	850	299	977	456	0.849	10.2	0.318	137	110
203 x 203 x 71	7620	2540	9.18	5.30	706	246	799	374	0.853	11.9	0.250	80.2	90.4
203 x 203 x 60	6130	2070	8.96	5.20	584	201	656	305	0.846	14.1	0.197	47.2	76.4
203 x 203 x 52	5260	1780	8.91	5.18	510	174	567	264	0.848	15.8	0.167	31.8	66.3
203 x 203 x 46	4570	1550	8.82	5.13	450	152	497	231	0.846	17.7	0.143	22.2	58.7
152 x 152 x 37	2210	706	6.85	3.87	273	91.5	309	140	0.849	13.3	0.0399	19.2	47.1
152 x 152 x 30	1750	560	6.76	3.83	222	73.3	248	112	0.849	16.0	0.0308	10.5	38.3
152 x 152 x 23	1250	400	6.54	3.70	164	52.6	182	80.2	0.840	20.7	0.0212	4.63	29.2

Check availability.

For explanation of tables refer to the Handbook of Structural Steelwork - 3rd edition

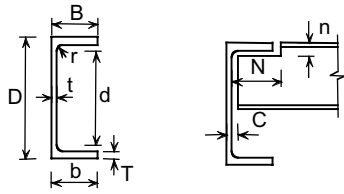

Section Designation	Mass per Metre kg/m	Depth of Section D mm	Width of Section B mm	Thickness		Root Radius r mm	Depth between Fillets d mm	Ratios for Local Buckling		Dimensions for Detailing			Surface Area	
				Web t mm	Flange T mm			Flange b/T	Web d/t	End Clearance C mm	Notch		Per Metre m ²	Per Tonne m ²
											N mm	n mm		
430 x 100 x 64	64.4	430	100	11.0	19.0	15	362	5.26	32.9	13	96	36	1.23	19.0
380 x 100 x 54	54.0	380	100	9.5	17.5	15	315	5.71	33.2	12	98	34	1.13	20.9
300 x 100 x 46	45.5	300	100	9.0	16.5	15	237	6.06	26.3	11	98	32	0.969	21.3
300 x 90 x 41	41.4	300	90	9.0	15.5	12	245	5.81	27.2	11	88	28	0.932	22.5
260 x 90 x 35	34.8	260	90	8.0	14.0	12	208	6.43	26.0	10	88	28	0.854	24.5
260 x 75 x 28	27.6	260	75	7.0	12.0	12	212	6.25	30.3	9	74	26	0.796	28.8
230 x 90 x 32	32.2	230	90	7.5	14.0	12	178	6.43	23.7	10	90	28	0.795	24.7
230 x 75 x 26	25.7	230	75	6.5	12.5	12	181	6.00	27.8	9	76	26	0.737	28.7
200 x 90 x 30	29.7	200	90	7.0	14.0	12	148	6.43	21.1	9	90	28	0.736	24.8
200 x 75 x 23	23.4	200	75	6.0	12.5	12	151	6.00	25.2	8	76	26	0.678	28.9
180 x 90 x 26	26.1	180	90	6.5	12.5	12	131	7.20	20.2	9	90	26	0.697	26.7
180 x 75 x 20	20.3	180	75	6.0	10.5	12	135	7.14	22.5	8	76	24	0.638	31.4
150 x 90 x 24	23.9	150	90	6.5	12.0	12	102	7.50	15.7	9	90	26	0.637	26.7
150 x 75 x 18	17.9	150	75	5.5	10.0	12	106	7.50	19.3	8	76	24	0.579	32.4
125 x 65 x 15 #	14.8	125	65	5.5	9.5	12	82.0	6.84	14.9	8	66	22	0.489	33.1
100 x 50 x 10 #	10.2	100	50	5.0	8.5	9	65.0	5.88	13.0	7	52	18	0.382	37.5

Check availability.

For explanation of tables refer to the Handbook of Structural Steelwork - 3rd edition

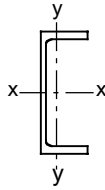

Section Designation	Second Moment of Area		Radius of Gyration		Elastic Modulus		Plastic Modulus		Buckling Parameter u	Torsional Index x	Warping Constant H dm6	Torsional Constant J cm4	Area of Section A cm2
	Axis x-x cm4	Axis y-y cm4	Axis x-x cm	Axis y-y cm	Axis x-x cm3	Axis y-y cm3	Axis x-x cm3	Axis y-y cm3					
430 x 100 x 64	21900	722	16.3	2.97	1020	97.9	1220	176	0.917	22.5	0.219	63.0	82.1
380 x 100 x 54	15000	643	14.8	3.06	791	89.2	933	161	0.933	21.2	0.150	45.7	68.7
300 x 100 x 46	8230	568	11.9	3.13	549	81.7	641	148	0.944	17.0	0.0813	36.8	58.0
300 x 90 x 41	7220	404	11.7	2.77	481	63.1	568	114	0.934	18.4	0.0581	28.8	52.7
260 x 90 x 35	4730	353	10.3	2.82	364	56.3	425	102	0.943	17.2	0.0379	20.6	44.4
260 x 75 x 28	3620	185	10.1	2.30	278	34.4	328	62.0	0.932	20.5	0.0203	11.7	35.1
230 x 90 x 32	3520	334	9.27	2.86	306	55.0	355	98.9	0.949	15.1	0.0279	19.3	41.0
230 x 75 x 26	2750	181	9.17	2.35	239	34.8	278	63.2	0.945	17.3	0.0153	11.8	32.7
200 x 90 x 30	2520	314	8.16	2.88	252	53.4	291	94.5	0.952	12.9	0.0197	18.3	37.9
200 x 75 x 23	1960	170	8.11	2.39	196	33.8	227	60.6	0.956	14.7	0.0107	11.1	29.9
180 x 90 x 26	1820	277	7.40	2.89	202	47.4	232	83.5	0.950	12.8	0.0141	13.3	33.2
180 x 75 x 20	1370	146	7.27	2.38	152	28.8	176	51.8	0.945	15.3	0.00754	7.34	25.9
150 x 90 x 24	1160	253	6.18	2.89	155	44.4	179	76.9	0.937	10.8	0.00890	11.8	30.4
150 x 75 x 18	861	131	6.15	2.40	115	26.6	132	47.2	0.945	13.1	0.00467	6.10	22.8
125 x 65 x 15 #	483	80.0	5.07	2.06	77.3	18.8	89.9	33.2	0.942	11.1	0.00194	4.72	18.8
100 x 50 x 10 #	208	32.3	4.00	1.58	41.5	9.89	48.9	17.5	0.942	10.0	0.000491	2.53	13.0

Check availability.

For explanation of tables refer to the Handbook of Structural Steelwork - 3rd edition

Hot Finished Circular Hollow Sections - Dimensions and Properties

BS 5950-1: 2000

BS EN 10210-2: 1997

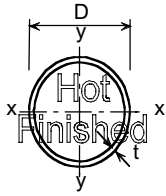

Section Designation		Mass per Metre · · · kg/m	Area of Section · · · A · · · cm ²	Ratio for Local Buckling · · · D/t · · · ·	Second Moment of Area · · · I · · · cm ⁴	Radius of Gyration · · · r · · · cm	Elastic Modulus · · · Z · · · cm ³	Plastic Modulus · · · S · · · cm ³	Torsional Constants		Surface Area · · · · · · · ·	
Outside Diameter · · · D · · · mm	Thickness · · · t · · · mm								· · · J · · · cm ⁴	· · · C · · · cm ³	Per Metre · · · · · · · m ²	Per Tonne · · · · · · · m ²
26.9	3.2 ~	1.87	2.38	8.41	1.70	0.846	1.27	1.81	3.41	2.53	0.0845	45.2
42.4	3.2 ~	3.09	3.94	13.3	7.62	1.39	3.59	4.93	15.2	7.19	0.133	43.0
48.3	3.2 ~	3.56	4.53	15.1	11.6	1.60	4.80	6.52	23.2	9.59	0.152	42.7
48.3	4.0 ~	4.37	5.57	12.1	13.8	1.57	5.70	7.87	27.5	11.4	0.152	34.8
48.3	5.0 ~	5.34	6.80	9.66	16.2	1.54	6.69	9.42	32.3	13.4	0.152	28.5
60.3	3.2 ~	4.51	5.74	18.8	23.5	2.02	7.78	10.4	46.9	15.6	0.189	41.9
60.3	5.0 ~	6.82	8.69	12.1	33.5	1.96	11.1	15.3	67.0	22.2	0.189	27.7
76.1	2.9 ^	5.24	6.67	26.2	44.7	2.59	11.8	15.5	89.0	23.5	0.239	45.6
76.1	3.2 ~	5.75	7.33	23.8	48.8	2.58	12.8	17.0	97.6	25.6	0.239	41.6
76.1	4.0 ~	7.11	9.06	19.0	59.1	2.55	15.5	20.8	118	31.0	0.239	33.6
76.1	5.0 ~	8.77	11.2	15.2	70.9	2.52	18.6	25.3	142	37.3	0.239	27.3
88.9	3.2 ~	6.76	8.62	27.8	79.2	3.03	17.8	23.5	158	35.6	0.279	41.3
88.9	4.0 ~	8.38	10.7	22.2	96.3	3.00	21.7	28.9	193	43.3	0.279	33.3
88.9	5.0 ~	10.4	13.2	17.8	116	2.97	26.2	35.2	233	52.4	0.279	27.0
88.9	6.3 ~	12.8	16.3	14.1	140	2.93	31.5	43.1	280	63.1	0.279	21.7
114.3	3.2 ~	8.77	11.2	35.7	172	3.93	30.2	39.5	345	60.4	0.359	40.9
114.3	3.6	9.83	12.5	31.8	192	3.92	33.6	44.1	384	67.2	0.359	36.5
114.3	5.0	13.5	17.2	22.9	257	3.87	45.0	59.8	514	89.9	0.359	26.6
114.3	6.3	16.8	21.4	18.1	313	3.82	54.7	73.6	625	109	0.359	21.4
139.7	5.0	16.6	21.2	27.9	481	4.77	68.8	90.8	961	138	0.439	26.4
139.7	6.3	20.7	26.4	22.2	589	4.72	84.3	112	1180	169	0.439	21.2
139.7	8.0 ~	26.0	33.1	17.5	720	4.66	103	139	1440	206	0.439	16.9
139.7	10.0 ~	32.0	40.7	14.0	862	4.60	123	169	1720	247	0.439	13.7
168.3	5.0 ~	20.1	25.7	33.7	856	5.78	102	133	1710	203	0.529	26.3
168.3	6.3 ~	25.2	32.1	26.7	1050	5.73	125	165	2110	250	0.529	21.0
168.3	8.0 ~	31.6	40.3	21.0	1300	5.67	154	206	2600	308	0.529	16.7
168.3	10.0 ~	39.0	49.7	16.8	1560	5.61	186	251	3130	372	0.529	13.6
193.7	5.0 ~	23.3	29.6	38.7	1320	6.67	136	178	2640	273	0.609	26.1
193.7	6.3 ~	29.1	37.1	30.7	1630	6.63	168	221	3260	337	0.609	20.9
193.7	8.0 ~	36.6	46.7	24.2	2020	6.57	208	276	4030	416	0.609	16.6
193.7	10.0 ~	45.3	57.7	19.4	2440	6.50	252	338	4880	504	0.609	13.4

~ Check availability in S275.

^ Check availability in S355.

For explanation of tables refer to the Handbook of Structural Steelwork - 3rd edition

Hot Finished Circular Hollow Sections - Dimensions and Properties

BS 5950-1: 2000

BS EN 10210-2: 1997

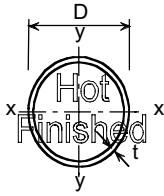

Section Designation		Mass per Metre kg/m	Area of Section A cm ²	Ratio for Local Buckling D/t	Second Moment of Area I cm ⁴	Radius of Gyration r cm	Elastic Modulus Z cm ³	Plastic Modulus S cm ³	Torsional Constants		Surface Area	
Outside Diameter D mm	Thickness t mm								J cm ⁴	C cm ³	Per Metre m ²	Per Tonne m ²
219.1	5.0 ~	26.4	33.6	43.8	1930	7.57	176	229	3860	352	0.688	26.1
219.1	6.3 ~	33.1	42.1	34.8	2390	7.53	218	285	4770	436	0.688	20.8
219.1	8.0 ~	41.6	53.1	27.4	2960	7.47	270	357	5920	540	0.688	16.5
219.1	10.0 ~	51.6	65.7	21.9	3600	7.40	328	438	7200	657	0.688	13.3
219.1	12.5 ~	63.7	81.1	17.5	4350	7.32	397	534	8690	793	0.688	10.80
244.5	12.0 ~	68.8	87.7	20.4	5940	8.23	486	649	11900	972	0.768	11.16
273.0	5.0 ~	33.0	42.1	54.6	3780	9.48	277	359	7560	554	0.858	26.0
273.0	6.3	41.4	52.8	43.3	4700	9.43	344	448	9390	688	0.858	20.7
273.0	8.0 ~	52.3	66.6	34.1	5850	9.37	429	562	11700	857	0.858	16.4
273.0	10.0	64.9	82.6	27.3	7150	9.31	524	692	14300	1050	0.858	13.2
273.0	12.5	80.3	102	21.8	8700	9.22	637	849	17400	1270	0.858	10.68
273.0	16.0 ~	101	129	17.1	10700	9.10	784	1060	21400	1570	0.858	8.46
323.9	6.3 ~	49.3	62.9	51.4	7930	11.2	490	636	15900	979	1.02	20.7
323.9	8.0 ~	62.3	79.4	40.5	9910	11.2	612	799	19800	1220	1.02	16.4
323.9	10.0 ~	77.4	98.6	32.4	12200	11.1	751	986	24300	1500	1.02	13.2
323.9	12.5 ~	96.0	122	25.9	14800	11.0	917	1210	29700	1830	1.02	10.63
323.9	16.0	122	155	20.2	18400	10.9	1140	1520	36800	2270	1.02	8.40
406.4	6.3 ~	62.2	79.2	64.5	15900	14.1	780	1010	31700	1560	1.28	20.6
406.4	8.0 ~	78.6	100	50.8	19900	14.1	978	1270	39700	1960	1.28	16.3
406.4	10.0 ~	97.8	125	40.6	24500	14.0	1210	1570	49000	2410	1.28	13.1
406.4	12.5 ~	121	155	32.5	30000	13.9	1480	1940	60100	2960	1.28	10.54
406.4	16.0	154	196	25.4	37500	13.8	1840	2440	74900	3690	1.28	8.31
457.0	8.0 ~	88.6	113	57.1	28500	15.9	1250	1610	56900	2490	1.44	16.3
457.0	10.0 ~	110	140	45.7	35100	15.8	1540	2000	70200	3070	1.44	13.1
457.0	12.5 ~	137	175	36.6	43100	15.7	1890	2470	86300	3780	1.44	10.51
457.0	16.0	174	222	28.6	54000	15.6	2360	3110	108000	4730	1.44	8.28
508.0	8.0 ~	98.6	126	63.5	39300	17.7	1550	2000	78600	3090	1.60	16.2
508.0	10.0 ~	123	156	50.8	48500	17.6	1910	2480	97000	3820	1.60	13.0
508.0	12.5	153	195	40.6	59800	17.5	2350	3070	120000	4710	1.60	10.46
508.0	16.0 ~	194	247	31.8	74900	17.4	2950	3870	150000	5900	1.60	8.25
508.0	20.0 ~	241	307	25.4	91400	17.3	3600	4770	183000	7200	1.60	6.64

~ Check availability S275.

For explanation of tables refer to the Handbook of Structural Steelwork - 3rd edition

Hot Finished Square Hollow Sections - Dimensions and Properties

BS 5950-1: 2000

BS EN 10210-2: 1997

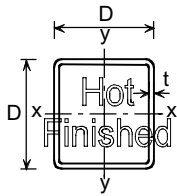

Section Designation		Mass per Metre kg/m	Area of Section A cm ²	Ratio for Local Buckling d/t (1)	Second Moment of Area I cm ⁴	Radius of Gyration r cm	Elastic Modulus Z cm ³	Plastic Modulus S cm ³	Torsional Constants		Surface Area	
Size D x D mm	Thickness t mm								J cm ⁴	C cm ³	Per Metre m ²	Per Tonne m ²
40 x 40	3.0 ~	3.41	4.34	10.3	9.78	1.50	4.89	5.97	15.7	7.10	0.152	44.6
40 x 40	3.2 ~	3.61	4.60	9.50	10.2	1.49	5.11	6.28	16.5	7.42	0.152	42.1
40 x 40	4.0	4.39	5.59	7.00	11.8	1.45	5.91	7.44	19.5	8.54	0.150	34.2
40 x 40	5.0 ~	5.28	6.73	5.00	13.4	1.41	6.68	8.66	22.5	9.60	0.147	27.8
50 x 50	3.0 ~	4.35	5.54	13.7	20.2	1.91	8.08	9.70	32.1	11.8	0.192	44.1
50 x 50	3.2 ~	4.62	5.88	12.6	21.2	1.90	8.49	10.2	33.8	12.4	0.192	41.6
50 x 50	4.0	5.64	7.19	9.50	25.0	1.86	9.99	12.3	40.4	14.5	0.190	33.7
50 x 50	5.0	6.85	8.73	7.00	28.9	1.82	11.6	14.5	47.6	16.7	0.187	27.3
50 x 50	6.3 ~	8.31	10.6	4.94	32.8	1.76	13.1	17.0	55.2	18.8	0.184	22.1
60 x 60	3.0 ~	5.29	6.74	17.0	36.2	2.32	12.1	14.3	56.9	17.7	0.232	43.9
60 x 60	3.2 ~	5.62	7.16	15.8	38.2	2.31	12.7	15.2	60.2	18.6	0.232	41.3
60 x 60	4.0 ~	6.90	8.79	12.0	45.4	2.27	15.1	18.3	72.5	22.0	0.230	33.3
60 x 60	5.0	8.42	10.7	9.00	53.3	2.23	17.8	21.9	86.4	25.7	0.227	27.0
60 x 60	6.3 ~	10.3	13.1	6.52	61.6	2.17	20.5	26.0	102	29.6	0.224	21.7
60 x 60	8.0 ~	12.5	16.0	4.50	69.7	2.09	23.2	30.4	118	33.4	0.219	17.5
70 x 70	3.6 ~	7.40	9.42	16.4	68.6	2.70	19.6	23.3	108	28.7	0.271	36.6
70 x 70	5.0 ~	9.99	12.7	11.0	88.5	2.64	25.3	30.8	142	36.8	0.267	26.7
70 x 70	6.3 ~	12.3	15.6	8.11	104	2.58	29.7	36.9	169	42.9	0.264	21.5
70 x 70	8.0 ~	15.0	19.2	5.75	120	2.50	34.2	43.8	200	49.2	0.259	17.3
80 x 80	3.6 ~	8.53	10.9	19.2	105	3.11	26.2	31.0	164	38.5	0.311	36.5
80 x 80	4.0 ~	9.41	12.0	17.0	114	3.09	28.6	34.0	180	41.9	0.310	32.9
80 x 80	5.0 ~	11.6	14.7	13.0	137	3.05	34.2	41.1	217	49.8	0.307	26.6
80 x 80	6.3	14.2	18.1	9.70	162	2.99	40.5	49.7	262	58.7	0.304	21.4
80 x 80	8.0 ~	17.5	22.4	7.00	189	2.91	47.3	59.5	312	68.3	0.299	17.1
90 x 90	3.6 ~	9.66	12.3	22.0	152	3.52	33.8	39.7	237	49.7	0.351	36.3
90 x 90	4.0 ~	10.7	13.6	19.5	166	3.50	37.0	43.6	260	54.2	0.350	32.7
90 x 90	5.0 ~	13.1	16.7	15.0	200	3.45	44.4	53.0	316	64.8	0.347	26.5
90 x 90	6.3 ~	16.2	20.7	11.3	238	3.40	53.0	64.3	382	77.0	0.344	21.2
90 x 90	8.0 ~	20.1	25.6	8.25	281	3.32	62.6	77.6	459	90.5	0.339	16.9
100 x 100	4.0	11.9	15.2	22.0	232	3.91	46.4	54.4	361	68.2	0.390	32.8
100 x 100	5.0	14.7	18.7	17.0	279	3.86	55.9	66.4	439	81.8	0.387	26.3
100 x 100	6.3	18.2	23.2	12.9	336	3.80	67.1	80.9	534	97.8	0.384	21.1
100 x 100	8.0 ~	22.6	28.8	9.50	400	3.73	79.9	98.2	646	116	0.379	16.8
100 x 100	10.0	27.4	34.9	7.00	462	3.64	92.4	116	761	133	0.374	13.6
120 x 120	5.0 ~	17.8	22.7	21.0	498	4.68	83.0	97.6	777	122	0.467	26.2
120 x 120	6.3	22.2	28.2	16.0	603	4.62	100	120	950	147	0.464	20.9
120 x 120	8.0 ~	27.6	35.2	12.0	726	4.55	121	147	1160	176	0.459	16.6
120 x 120	10.0 ~	33.7	42.9	9.00	852	4.46	142	175	1380	206	0.454	13.5
120 x 120	12.5 ~	40.9	52.1	6.60	982	4.34	164	207	1620	236	0.448	11.0

~ Check availability in S275.

(1) For local buckling calculation $d = D - 3t$.

For explanation of tables refer to the Handbook of Structural Steelwork - 3rd edition

Hot Finished Square Hollow Sections - Dimensions and Properties

BS 5950-1: 2000

BS EN 10210-2: 1997

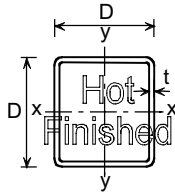

Section Designation		Mass per Metre kg/m	Area of Section A cm ²	Ratio for Local Buckling d/t (1)	Second Moment of Area I cm ⁴	Radius of Gyration r cm	Elastic Modulus Z cm ³	Plastic Modulus S cm ³	Torsional Constants		Surface Area	
Size D x D mm	Thickness t mm								J cm ⁴	C cm ³	Per Metre m ²	Per Tonne m ²
140 x 140	5.0 ~	21.0	26.7	25.0	807	5.50	115	135	1250	170	0.547	26.0
140 x 140	6.3 ~	26.1	33.3	19.2	984	5.44	141	166	1540	206	0.544	20.8
140 x 140	8.0 ~	32.6	41.6	14.5	1200	5.36	171	204	1890	249	0.539	16.5
140 x 140	10.0 ~	40.0	50.9	11.0	1420	5.27	202	246	2270	294	0.534	13.4
140 x 140	12.5 ~	48.7	62.1	8.20	1650	5.16	236	293	2700	342	0.528	10.8
150 x 150	5.0 ~	22.6	28.7	27.0	1000	5.90	134	156	1550	197	0.587	26.0
150 x 150	6.3	28.1	35.8	20.8	1220	5.85	163	192	1910	240	0.584	20.8
150 x 150	8.0 ~	35.1	44.8	15.8	1490	5.77	199	237	2350	291	0.579	16.5
150 x 150	10.0	43.1	54.9	12.0	1770	5.68	236	286	2830	344	0.574	13.3
150 x 150	12.5 ~	52.7	67.1	9.00	2080	5.57	277	342	3370	402	0.568	10.8
150 x 150	16.0 ~	65.2	83.0	6.38	2430	5.41	324	411	4030	467	0.559	8.57
160 x 160	5.0 ~	24.1	30.7	29.0	1230	6.31	153	178	1890	226	0.627	26.0
160 x 160	6.3 ~	30.1	38.3	22.4	1500	6.26	187	220	2330	275	0.624	20.7
160 x 160	8.0 ~	37.6	48.0	17.0	1830	6.18	229	272	2880	335	0.619	16.5
160 x 160	10.0 ~	46.3	58.9	13.0	2190	6.09	273	329	3480	398	0.614	13.3
160 x 160	12.5 ~	56.6	72.1	9.80	2580	5.98	322	395	4160	467	0.608	10.7
180 x 180	6.3 ~	34.0	43.3	25.6	2170	7.07	241	281	3360	355	0.704	20.7
180 x 180	8.0 ~	42.7	54.4	19.5	2660	7.00	296	349	4160	434	0.699	16.4
180 x 180	10.0 ~	52.5	66.9	15.0	3190	6.91	355	424	5050	518	0.694	13.2
180 x 180	12.5 ~	64.4	82.1	11.4	3790	6.80	421	511	6070	613	0.688	10.7
180 x 180	16.0 ~	80.2	102	8.25	4500	6.64	500	621	7340	724	0.679	8.47
200 x 200	5.0 ~	30.4	38.7	37.0	2450	7.95	245	283	3760	362	0.787	25.9
200 x 200	6.3 ~	38.0	48.4	28.7	3010	7.89	301	350	4650	444	0.784	20.6
200 x 200	8.0 ~	47.7	60.8	22.0	3710	7.81	371	436	5780	545	0.779	16.3
200 x 200	10.0	58.8	74.9	17.0	4470	7.72	447	531	7030	655	0.774	13.2
200 x 200	12.5 ~	72.3	92.1	13.0	5340	7.61	534	643	8490	778	0.768	10.6
200 x 200	16.0 ~	90.3	115	9.50	6390	7.46	639	785	10300	927	0.759	8.41
250 x 250	6.3 ~	47.9	61.0	36.7	6010	9.93	481	556	9240	712	0.984	20.5
250 x 250	8.0 ~	60.3	76.8	28.3	7460	9.86	596	694	11500	880	0.979	16.2
250 x 250	10.0 ~	74.5	94.9	22.0	9060	9.77	724	851	14100	1070	0.974	13.1
250 x 250	12.5 ~	91.9	117	17.0	10900	9.66	873	1040	17200	1280	0.968	10.5
250 x 250	16.0 ~	115	147	12.6	13300	9.50	1060	1280	21100	1550	0.959	8.31
300 x 300	6.3 ~	57.8	73.6	44.6	10500	12.0	703	809	16100	1040	1.18	20.4
300 x 300	8.0 ~	72.8	92.8	34.5	13100	11.9	875	1010	20200	1290	1.18	16.2
300 x 300	10.0 ~	90.2	115	27.0	16000	11.8	1070	1250	24800	1580	1.17	13.0
300 x 300	12.5 ~	112	142	21.0	19400	11.7	1300	1530	30300	1900	1.17	10.5
300 x 300	16.0 ~	141	179	15.8	23900	11.5	1590	1900	37600	2330	1.16	8.26
350 x 350	8.0 ~	85.4	109	40.8	21100	13.9	1210	1390	32400	1790	1.38	16.2
350 x 350	10.0 ~	106	135	32.0	25900	13.9	1480	1720	39900	2190	1.37	12.9
350 x 350	12.5 ~	131	167	25.0	31500	13.7	1800	2110	48900	2650	1.37	10.5
350 x 350	16.0 ~	166	211	18.9	38900	13.6	2230	2630	61000	3260	1.36	8.19
400 x 400	10.0 ~	122	155	37.0	39100	15.9	1960	2260	60100	2900	1.57	12.9
400 x 400	12.5	151	192	29.0	47800	15.8	2390	2780	73900	3530	1.57	10.4
400 x 400	16.0 ~	191	243	22.0	59300	15.6	2970	3480	92400	4360	1.56	8.17
400 x 400	20.0 ~	235	300	17.0	71500	15.4	3580	4250	113000	5240	1.55	6.60

~ Check availability in S275.

(1) For local buckling calculation $d = D - 3t$.

For explanation of tables refer to the Handbook of Structural Steelwork - 3rd edition

Hot Finished Rectangular Hollow Sections - Dimensions and Properties

BS 5950-1: 2000

BS EN 10210-2: 1997

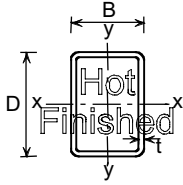

Section Designation		Mass per Metre	Area of Section	Ratios for Local Buckling		Second Moment of Area		Radius of Gyration		Elastic Modulus		Plastic Modulus		Torsional Constants		Surface Area	
Size	Thickness			d/t (1)	b/t (1)	Axis x-x	Axis y-y	Axis x-x	Axis y-y	Axis x-x	Axis y-y	Axis x-x	Axis y-y	J	C	Per Metre	Per Tonne
D x B	t	kg/m	A			cm ⁴	cm ⁴	cm	cm	cm ³	cm ³	cm ³	cm ³	cm ⁴	cm ³	m ²	m ²
50 x 30	3.2 ~	3.61	4.60	12.6	6.38	14.2	6.20	1.76	1.16	5.68	4.13	7.25	5.00	14.19	6.80	0.152	42.1
60 x 40	3.0 ~	4.35	5.54	17.0	10.3	26.5	13.9	2.18	1.58	8.82	6.95	10.9	8.19	29.2	11.2	0.192	44.1
60 x 40	4.0 ~	5.64	7.19	12.0	7.00	32.8	17.0	2.14	1.54	10.9	8.52	13.8	10.3	36.7	13.7	0.190	33.7
60 x 40	5.0 ~	6.85	8.73	9.00	5.00	38.1	19.5	2.09	1.50	12.7	9.77	16.4	12.2	43.0	15.7	0.187	27.3
80 x 40	3.2 ~	5.62	7.16	22.0	9.50	57.2	18.9	2.83	1.63	14.3	9.46	18.0	11.0	46.2	16.1	0.232	41.3
80 x 40	4.0 ~	6.90	8.79	17.0	7.00	68.2	22.2	2.79	1.59	17.1	11.1	21.8	13.2	55.2	18.9	0.230	33.3
80 x 40	5.0 ~	8.42	10.7	13.0	5.00	80.3	25.7	2.74	1.55	20.1	12.9	26.1	15.7	65.1	21.9	0.227	27.0
80 x 40	6.3 ~	10.3	13.1	9.70	3.35	93.3	29.2	2.67	1.49	23.3	14.6	31.1	18.4	75.6	24.8	0.224	21.7
80 x 40	8.0 ~	12.5	16.0	7.00	2.00	106	32.1	2.58	1.42	26.5	16.1	36.5	21.2	85.8	27.4	0.219	17.5
90 x 50	3.6 ~	7.40	9.42	22.0	10.9	98.3	38.7	3.23	2.03	21.8	15.5	27.2	18.0	89.4	25.9	0.271	36.6
90 x 50	5.0 ~	9.99	12.7	15.0	7.00	127	49.2	3.16	1.97	28.3	19.7	36.0	23.5	116	32.9	0.267	26.7
90 x 50	6.3 ~	12.3	15.6	11.3	4.94	150	57.0	3.10	1.91	33.3	22.8	43.2	28.0	138	38.1	0.264	21.5
100 x 50	3.0 ~	6.71	8.54	30.3	13.7	110	36.8	3.58	2.08	21.9	14.7	27.3	16.8	88.4	25.0	0.292	43.5
100 x 50	3.2 ~	7.13	9.08	28.3	12.6	116	38.8	3.57	2.07	23.2	15.5	28.9	17.7	93.4	26.4	0.292	41.0
100 x 50	5.0 ~	10.8	13.7	17.0	7.00	167	54.3	3.48	1.99	33.3	21.7	42.6	25.8	135	36.9	0.287	26.6
100 x 50	6.3 ~	13.3	16.9	12.9	4.94	197	63.0	3.42	1.93	39.4	25.2	51.3	30.8	160	42.9	0.284	21.4
100 x 50	8.0 ~	16.3	20.8	9.50	3.25	230	71.7	3.33	1.86	46.0	28.7	61.4	36.3	186	48.9	0.279	17.1
100 x 50	10.0 ^	19.6	24.9	7.00	2.00	259	78.4	3.22	1.77	51.8	31.4	71.2	41.4	209	53.6	0.274	14.0
100 x 60	3.6 ~	8.53	10.9	24.8	13.7	145	64.8	3.65	2.44	28.9	21.6	35.6	24.9	142	35.6	0.311	36.5
100 x 60	5.0 ~	11.6	14.7	17.0	9.00	189	83.6	3.58	2.38	37.8	27.9	47.4	32.9	188	45.9	0.307	26.5
100 x 60	6.3 ~	14.2	18.1	12.9	6.52	225	98.1	3.52	2.33	45.0	32.7	57.3	39.5	224	53.8	0.304	21.4
100 x 60	8.0 ~	17.5	22.4	9.50	4.50	264	113	3.44	2.25	52.8	37.8	68.7	47.1	265	62.2	0.299	17.1
120 x 60	3.6 ~	9.70	12.3	30.3	13.7	227	76.3	4.30	2.49	37.9	25.4	47.2	28.9	183	43.3	0.351	36.2
120 x 60	5.0 ~	13.1	16.7	21.0	9.00	299	98.8	4.23	2.43	49.9	32.9	63.1	38.4	242	56.0	0.347	26.5
120 x 60	6.3 ~	16.2	20.7	16.0	6.52	358	116	4.16	2.37	59.7	38.8	76.7	46.3	290	65.9	0.344	21.2
120 x 60	8.0 ~	20.1	25.6	12.0	4.50	425	135	4.08	2.30	70.8	45.0	92.7	55.4	344	76.6	0.339	16.9
120 x 80	5.0 ~	14.7	18.7	21.0	13.0	365	193	4.42	3.21	60.9	48.2	74.6	56.1	401	77.9	0.387	26.3
120 x 80	6.3	18.2	23.2	16.0	9.70	440	230	4.36	3.15	73.3	57.6	91.0	68.2	487	92.9	0.384	21.1
120 x 80	8.0	22.6	28.8	12.0	7.00	525	273	4.27	3.08	87.5	68.1	111	82.6	587	110	0.379	16.8
120 x 80	10.0 ~	27.4	34.9	9.00	5.00	609	313	4.18	2.99	102	78.1	131	97.3	688	126	0.374	13.6
150 x 100	5.0 ~	18.6	23.7	27.0	17.0	739	392	5.58	4.07	98.5	78.5	119	90.1	807	127	0.487	26.2
150 x 100	6.3	23.1	29.5	20.8	12.9	898	474	5.52	4.01	120	94.8	147	110	986	153	0.484	21.0
150 x 100	8.0 ~	28.9	36.8	15.8	9.50	1090	569	5.44	3.94	145	114	180	135	1200	183	0.479	16.6
150 x 100	10.0 ~	35.3	44.9	12.0	7.00	1280	665	5.34	3.85	171	133	216	161	1430	214	0.474	13.4
150 x 100	12.5 ~	42.8	54.6	9.00	5.00	1490	763	5.22	3.74	198	153	256	190	1680	246	0.468	10.9
160 x 80	4.0 ~	14.4	18.4	37.0	17.0	612	207	5.77	3.35	76.5	51.7	94.7	58.3	493	88.0	0.470	32.6
160 x 80	5.0 ~	17.8	22.7	29.0	13.0	744	249	5.72	3.31	93.0	62.3	116	71.1	600	106	0.467	26.2
160 x 80	6.3	22.2	28.2	22.4	9.70	903	299	5.66	3.26	113	74.8	142	86.8	730	127	0.464	20.9
160 x 80	8.0	27.6	35.2	17.0	7.00	1090	356	5.57	3.18	136	89.0	175	106	883	151	0.459	16.6
160 x 80	10.0 ~	33.7	42.9	13.0	5.00	1280	411	5.47	3.10	161	103	209	125	1040	175	0.454	13.5

~ Check availability in S275.

^ Check availability in S355.

(1) For local buckling calculation $d = D - 3t$ and $b = B - 3t$.

For explanation of tables refer to the Handbook of Structural Steelwork - 3rd edition

Hot Finished Rectangular Hollow Sections - Dimensions and Properties

BS 5950-1: 2000

BS EN 10210-2: 1997

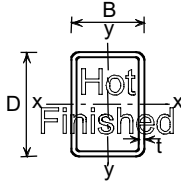

Section Designation		Mass per Metre kg/m	Area of Section A cm ²	Ratios for Local Buckling		Second Moment of Area		Radius of Gyration		Elastic Modulus		Plastic Modulus		Torsional Constants		Surface Area	
Size D x B mm	Thickness t mm			d/t (1)	b/t (1)	Axis x-x cm ⁴	Axis y-y cm ⁴	Axis x-x cm	Axis y-y cm	Axis x-x cm ³	Axis y-y cm ³	Axis x-x cm ³	Axis y-y cm ³	J cm ⁴	C cm ³	Per Metre m ²	Per Tonne m ²
200 x 100	5.0 ~	22.6	28.7	37.0	17.0	1500	505	7.21	4.19	149	101	185	114	1200	172	0.587	26.0
200 x 100	6.3 ~	28.1	35.8	28.7	12.9	1830	613	7.15	4.14	183	123	228	140	1470	208	0.584	20.8
200 x 100	8.0	35.1	44.8	22.0	9.50	2230	739	7.06	4.06	223	148	282	172	1800	251	0.579	16.5
200 x 100	10.0	43.1	54.9	17.0	7.00	2660	869	6.96	3.98	266	174	341	206	2160	295	0.574	13.3
200 x 100	12.5	52.7	67.1	13.0	5.00	3140	1000	6.84	3.87	314	201	408	245	2540	341	0.568	10.8
200 x 120	5.0 ~	24.1	30.7	37.0	21.0	1690	762	7.40	4.98	168	127	205	144	1650	210	0.627	26.0
200 x 120	6.3 ~	30.1	38.3	28.7	16.0	2070	929	7.34	4.92	207	155	253	177	2030	255	0.624	20.7
200 x 120	8.0 ~	37.6	48.0	22.0	12.0	2530	1130	7.26	4.85	253	188	313	218	2490	310	0.619	16.5
200 x 120	10.0 ~	46.3	58.9	17.0	9.00	3030	1340	7.17	4.76	303	223	379	263	3000	367	0.614	13.3
200 x 150	8.0 ~	41.4	52.8	22.0	15.8	2970	1890	7.50	5.99	297	253	359	294	3640	398	0.679	16.4
200 x 150	10.0 ~	51.0	64.9	17.0	12.0	3570	2260	7.41	5.91	357	302	436	356	4410	475	0.674	13.2
250 x 100	10.0 ~	51.0	64.9	22.0	7.00	4730	1070	8.54	4.06	379	214	491	251	2910	376	0.674	13.2
250 x 100	12.5 ~	62.5	79.6	17.0	5.00	5620	1250	8.41	3.96	450	249	592	299	3440	438	0.668	10.7
250 x 150	5.0 ~	30.4	38.7	47.0	27.0	3360	1530	9.31	6.28	269	204	324	228	3280	337	0.787	25.9
250 x 150	6.3	38.0	48.4	36.7	20.8	4140	1870	9.25	6.22	331	250	402	283	4050	413	0.784	20.6
250 x 150	8.0 ~	47.7	60.8	28.3	15.8	5110	2300	9.17	6.15	409	306	501	350	5020	506	0.779	16.3
250 x 150	10.0 ~	58.8	74.9	22.0	12.0	6170	2760	9.08	6.06	494	367	611	426	6090	605	0.774	13.2
250 x 150	12.5	72.3	92.1	17.0	9.00	7390	3270	8.96	5.96	591	435	740	514	7330	717	0.768	10.6
250 x 150	16.0 ~	90.3	115	12.6	6.38	8880	3870	8.79	5.80	710	516	906	625	8870	849	0.759	8.41
300 x 100	8.0 ~	47.7	60.8	34.5	9.50	6310	1080	10.2	4.21	420	216	546	245	3070	387	0.779	16.3
300 x 100	10.0 ~	58.8	74.9	27.0	7.00	7610	1280	10.1	4.13	508	255	666	296	3680	458	0.774	13.2
300 x 200	6.3 ~	47.9	61.0	44.6	28.7	7830	4190	11.3	8.29	522	419	624	472	8480	681	0.984	20.5
300 x 200	8.0 ~	60.3	76.8	34.5	22.0	9720	5180	11.3	8.22	648	518	779	589	10600	840	0.979	16.2
300 x 200	10.0 ~	74.5	94.9	27.0	17.0	11800	6280	11.2	8.13	788	628	956	721	12900	1020	0.974	13.1
300 x 200	12.5 ~	91.9	117	21.0	13.0	14300	7540	11.0	8.02	952	754	1170	877	15700	1220	0.968	10.5
300 x 200	16.0	115	147	15.8	9.50	17400	9110	10.9	7.87	1160	911	1440	1080	19300	1470	0.959	8.34
400 x 200	8.0 ~	72.8	92.8	47.0	22.0	19600	6660	14.5	8.47	978	666	1200	743	15700	1140	1.18	16.2
400 x 200	10.0 ~	90.2	115	37.0	17.0	23900	8080	14.4	8.39	1200	808	1480	911	19300	1380	1.17	13.0
400 x 200	12.5 ~	112	142	29.0	13.0	29100	9740	14.3	8.28	1450	974	1810	1110	23400	1660	1.17	10.5
400 x 200	16.0 ~	141	179	22.0	9.50	35700	11800	14.1	8.13	1790	1180	2260	1370	28900	2010	1.16	8.26
450 x 250	8.0 ~	85.4	109	53.3	28.3	30100	12100	16.6	10.6	1340	971	1620	1080	27100	1630	1.38	16.2
450 x 250	10.0 ~	106	135	42.0	22.0	36900	14800	16.5	10.5	1640	1190	2000	1330	33300	1990	1.37	12.9
450 x 250	12.5 ~	131	167	33.0	17.0	45000	18000	16.4	10.4	2000	1440	2460	1630	40700	2410	1.37	10.5
450 x 250	16.0	166	211	25.1	12.6	55700	22000	16.2	10.2	2480	1760	3070	2030	50500	2950	1.36	8.19
500 x 300	8.0 ~	98.0	125	59.5	34.5	43700	20000	18.7	12.6	1750	1330	2100	1480	42600	2200	1.58	16.1
500 x 300	10.0 ~	122	155	47.0	27.0	53800	24400	18.6	12.6	2150	1630	2600	1830	52400	2700	1.57	12.9
500 x 300	12.5 ~	151	192	37.0	21.0	65800	29800	18.5	12.5	2630	1990	3200	2240	64400	3280	1.57	10.4
500 x 300	16.0 ~	191	243	28.3	15.8	81800	36800	18.3	12.3	3270	2450	4010	2800	80300	4040	1.56	8.17
500 x 300	20.0 ~	235	300	22.0	12.0	98800	44100	18.2	12.1	3950	2940	4890	3410	97400	4840	1.55	6.60

~ Check availability in S275.

(1) For local buckling calculation $d = D - 3t$ and $b = B - 3t$.

For explanation of tables refer to the Handbook of Structural Steelwork - 3rd edition

UB Sections Subject to Bending - Restrained Beam Capacities for S275

BS 5950-1: 2000 BS 4-1: 1993

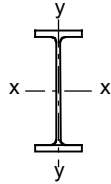

Section Designation	Section Classification	Shear Capacity P_v kN	Moment Capacity M_{cx} kNm	Ultimate U.D.L. Capacity (kN) for Restrained Beams For Lengths, L (m)												
				2.0	3.0	4.0	5.0	6.0	7.0	8.0	9.0	10.0	11.0	12.0	13.0	14.0
				1016x305x487 # +	Plastic	4760	5920	9510	9510	8830	7970	7180	6460	5810	5260	4730
1016x305x437 # +	Plastic	4220	5290	8440	8440	7880	7110	6410	5770	5200	4710	4240	3850	3530	3260	3030
1016x305x393 # +	Plastic	3790	4730	7590	7590	7070	6370	5740	5160	4650	4200	3780	3440	3150	2910	2700
1016x305x349 # +	Plastic	3380	4400	6760	6760	6450	5840	5270	4760	4290	3910	3520	3200	2930	2710	2510
1016x305x314 # +	Plastic	3040	3940	6070	6070	5790	5240	4730	4260	3850	3500	3150	2860	2620	2420	2250
1016x305x272 # +	Plastic	2600	3400	5200	5200	4990	4510	4070	3670	3320	3020	2720	2470	2270	2090	1940
1016x305x249 # +	Plastic	2570	3010	5140	5140	4650	4170	3730	3330	3010	2670	2410	2190	2010	1850	1720
1016x305x222 # +	Plastic	2470	2600	4940	4720	4210	3740	3310	2930	2600	2310	2080	1890	1730	1600	1490
914 x 419 x 388 #	Plastic	3130	4680	6270	6270	6270	5940	5400	4910	4470	4070	3750	3410	3120	2880	2680
914 x 419 x 343 #	Plastic	2810	4100	5630	5630	5630	5260	4780	4330	3930	3580	3280	2980	2730	2520	2340
914 x 305 x 289 #	Plastic	2870	3330	5750	5750	5200	4650	4150	3700	3330	2960	2660	2420	2220	2050	1900
914 x 305 x 253 #	Plastic	2530	2900	5050	5050	4550	4060	3620	3230	2900	2580	2320	2110	1930	1780	1660
914 x 305 x 224 #	Plastic	2300	2530	4600	4540	4050	3600	3190	2830	2530	2250	2020	1840	1680	1550	1440
914 x 305 x 201 #	Plastic	2170	2210	4340	4130	3660	3230	2840	2530	2210	1970	1770	1610	1480	1360	1260
838 x 292 x 226 #	Plastic	2180	2430	4360	4360	3890	3460	3060	2720	2430	2160	1940	1760	1620	1490	1390
838 x 292 x 194 #	Plastic	1960	2020	3930	3800	3360	2960	2600	2310	2020	1800	1620	1470	1350	1250	1160
838 x 292 x 176 #	Plastic	1860	1800	3720	3490	3060	2680	2350	2060	1800	1600	1440	1310	1200	1110	1030
762 x 267 x 197	Plastic	1910	1900	3820	3670	3220	2820	2460	2170	1900	1690	1520	1380	1270	1170	1090
762 x 267 x 173	Plastic	1730	1640	3470	3250	2840	2470	2150	1880	1640	1460	1310	1190	1090	1010	939
762 x 267 x 147	Plastic	1530	1370	3070	2790	2420	2090	1820	1560	1370	1210	1090	994	911	841	781
762 x 267 x 134	Plastic	1490	1280	2970	2650	2280	1970	1700	1460	1280	1140	1020	929	851	786	730
686 x 254 x 170	Plastic	1600	1490	3190	3010	2610	2260	1960	1710	1490	1330	1190	1090	995	918	853
686 x 254 x 152	Plastic	1440	1330	2890	2700	2330	2020	1740	1510	1330	1180	1060	964	883	815	757
686 x 254 x 140	Plastic	1350	1210	2700	2490	2150	1850	1610	1380	1210	1070	966	878	805	743	690
686 x 254 x 125	Plastic	1260	1060	2520	2240	1920	1640	1410	1210	1060	941	847	770	706	651	605
610 x 305 x 238	Plastic	1860	1980	3720	3720	3340	2920	2550	2240	1980	1760	1590	1440	1320	1220	1130
610 x 305 x 179	Plastic	1390	1470	2780	2780	2490	2170	1900	1660	1470	1310	1180	1070	980	905	840
610 x 305 x 149	Plastic	1150	1220	2300	2300	2060	1800	1570	1380	1220	1080	974	885	812	749	696
610 x 229 x 140	Plastic	1290	1100	2570	2340	1990	1700	1460	1250	1100	976	878	798	732	675	627
610 x 229 x 125	Plastic	1160	974	2320	2090	1780	1510	1300	1110	974	866	779	708	649	599	557
610 x 229 x 113	Plastic	1070	869	2140	1890	1600	1360	1160	994	869	773	696	632	580	535	497
610 x 229 x 101	Plastic	1040	792	2090	1770	1490	1250	1060	905	792	704	634	576	528	488	453

+ Section is not given in BS 4-1: 1993.

Check availability.

Section classification given applies to members subject to bending about the x-x axis only.

Loads given are the total Ultimate factored uniformly distributed load supported over a beam span L assuming full lateral restraint to the compression flange. Self weight of the section has not been allowed for.

UDL values in bold type are governed by the shear capacity.

The unfactored imposed load is assumed to be 40% of the ultimate load given. Unless otherwise indicated, it is only necessary to perform deflection checks if the ratio of unfactored imposed load to dead load is greater than 1.556.

UDL values to the right of the zigzag line in italic type may be susceptible to serviceability deflections $> L/360$ and so should be checked under imposed loading. (This deflection limit is for beams which carry a brittle finish.)

For explanation of tables refer to the Handbook of Structural Steelwork - 3rd edition

UB Sections Subject to Bending - Restrained Beam Capacities for S275

BS 5950-1: 2000

BS 4-1: 1993

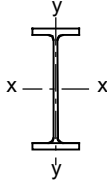

Section Designation	Section Classification	Shear Capacity P_v (kN)	Moment Capacity M_{cx} (kNm)	Ultimate U.D.L. Capacity (kN) for Restrained Beams for												
				Lengths, L (m)												
				2.0	3.0	4.0	5.0	6.0	7.0	8.0	9.0	10.0	11.0	12.0	13.0	14.0
533 x 210 x 122	Plastic	1100	847	2200	1900	1590	1340	1130	968	847	753	678	616	565	521	484
533 x 210 x 109	Plastic	995	749	1990	1700	1420	1190	999	856	749	666	600	545	500	461	428
533 x 210 x 101	Plastic	922	692	1840	1570	1310	1100	923	791	692	615	554	503	461	426	396
533 x 210 x 92	Plastic	888	649	1780	1490	1240	1040	865	742	649	577	519	472	433	399	371
533 x 210 x 82	Plastic	837	566	1620	1340	1100	906	755	647	566	503	453	412	377	348	324
457 x 191 x 98	Plastic	847	591	1690	1390	1140	946	789	676	591	526	473	430	394	364	338
457 x 191 x 89	Plastic	774	534	1540	1260	1030	854	712	610	534	474	427	388	356	328	305
457 x 191 x 82	Plastic	751	504	1480	1200	980	806	671	575	504	448	403	366	336	310	288
457 x 191 x 74	Plastic	679	455	1330	1090	885	727	606	520	455	404	364	331	303	280	260
457 x 191 x 67	Plastic	636	405	1220	983	794	647	539	462	405	360	324	294	270	249	231
457 x 152 x 82	Plastic	778	480	1460	1170	946	768	640	548	480	427	384	349	320	295	274
457 x 152 x 74	Plastic	705	431	1320	1060	851	690	575	493	431	383	345	314	287	265	246
457 x 152 x 67	Plastic	680	400	1240	993	799	639	533	457	400	355	320	291	266	246	228
457 x 152 x 60	Plastic	608	354	1110	881	708	566	472	404	354	315	283	257	236	218	202
457 x 152 x 52	Plastic	564	301	978	767	603	482	402	344	301	268	241	219	201	185	172
406 x 178 x 74	Plastic	647	413	1260	1010	811	660	550	472	413	367	330	300	275	254	236
406 x 178 x 67	Plastic	594	370	1140	911	730	592	494	423	370	329	296	269	247	228	212
406 x 178 x 60	Plastic	530	330	1020	812	650	528	440	377	330	293	264	240	220	203	188
406 x 178 x 54	Plastic	512	290	930	731	580	464	387	332	290	258	232	211	193	179	166

Section classification given applies to members subject to bending about the x-x axis only.

Loads given are the total Ultimate factored uniformly distributed load supported over a beam span L assuming full lateral restraint to the compression flange. Self weight of the section has not been allowed for.

UDL values in bold type are governed by the shear capacity.

The unfactored imposed load is assumed to be 40% of the ultimate load given. Unless otherwise indicated, it is only necessary to perform deflection checks if the ratio of unfactored imposed load to dead load is greater than 1.556.

UDL values to the right of the zigzag line in italic type may be susceptible to serviceability deflections $> L/360$ and so should be checked under imposed loading. (This deflection limit is for beams which carry a brittle finish.)

For explanation of tables refer to the Handbook of Structural Steelwork - 3rd edition

UB Sections Subject to Bending - Restrained Beam Capacities for S275

BS 5950-1: 2000

BS 4-1: 1993

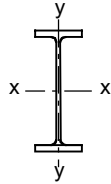

Section Designation	Section Classification	Shear Capacity Pv kN	Moment Capacity Mcx kNm	Ultimate U.D.L. Capacity (kN) for Restrained Beams for Lengths, L (m)													
				1.0	1.5	2.0	2.5	3.0	3.5	4.0	4.5	5.0	5.5	6.0	6.5	7.0	
				406 x 140 x 46	Plastic	452	244	905	902	799	705	623	550	488	434	391	355
406 x 140 x 39	Plastic	420	199	841	784	685	597	520	455	398	354	319	290	265	245	228	
356 x 171 x 67	Plastic	546	333	1090	1090	1050	933	829	738	659	592	533	484	444	410	381	
356 x 171 x 57	Plastic	478	278	957	957	895	791	700	620	556	494	444	404	370	342	317	
356 x 171 x 51	Plastic	433	246	867	867	801	707	624	552	493	438	394	358	329	303	282	
356 x 171 x 45	Plastic	406	213	812	812	715	626	549	482	426	379	341	310	284	262	244	
356 x 127 x 39	Plastic	385	181	770	727	632	548	475	414	362	322	290	264	242	223	207	
356 x 127 x 33	Plastic	346	149	691	623	536	460	398	341	299	265	239	217	199	184	171	
305 x 165 x 54	Plastic	405	233	809	809	765	672	591	522	465	414	372	338	310	286	266	
305 x 165 x 46	Plastic	339	198	678	678	648	569	501	443	396	352	317	288	264	244	226	
305 x 165 x 40	Plastic	300	171	601	601	566	496	436	385	343	305	274	249	228	211	196	
305 x 127 x 48	Plastic	462	196	924	835	712	607	521	447	391	348	313	284	261	241	223	
305 x 127 x 42	Plastic	406	169	811	727	618	526	450	386	338	300	270	246	225	208	193	
305 x 127 x 37	Plastic	357	148	713	639	543	462	395	339	296	264	237	216	198	182	169	
305 x 102 x 33	Plastic	341	132	681	584	493	416	353	302	265	235	212	192	176	163	151	
305 x 102 x 28	Plastic	306	111	598	503	421	355	296	253	222	197	177	161	148	136	127	
305 x 102 x 25	Plastic	292	94.1	539	446	367	301	251	215	188	167	150	137	125	116	107	
254 x 146 x 43	Plastic	308	156	617	617	544	469	406	356	311	277	249	226	208	192	178	
254 x 146 x 37	Plastic	266	133	532	532	467	402	347	304	266	236	213	193	177	163	152	
254 x 146 x 31	Plastic	249	108	498	468	396	336	288	247	216	192	173	157	144	133	124	
254 x 102 x 28	Plastic	271	97.1	541	449	372	311	259	222	194	173	155	141	129	119	111	
254 x 102 x 25	Plastic	255	84.2	489	401	328	269	224	192	168	150	135	122	112	104	96.2	
254 x 102 x 22	Plastic	239	71.2	434	350	285	228	190	163	142	127	114	<i>104</i>	<i>95.0</i>	<i>87.7</i>	<i>81.4</i>	
203 x 133 x 30	Plastic	218	86.4	437	395	327	273	230	197	173	154	138	126	115	106	98.7	
203 x 133 x 25	Plastic	191	71.0	382	332	272	227	189	162	142	126	114	103	94.6	87.3	81.1	
203 x 102 x 23	Plastic	181	64.4	362	305	249	206	172	147	129	114	103	93.6	85.8	79.2	73.5	
178 x 102 x 19	Plastic	141	47.0	282	229	184	150	125	107	<i>94.1</i>	<i>83.6</i>	<i>75.2</i>	<i>68.4</i>	<i>62.7</i>	<i>57.9</i>	<i>53.7</i>	
152 x 89 x 16	Plastic	113	33.8	220	171	135	108	90.2	<i>77.3</i>	<i>67.7</i>	<i>60.1</i>	<i>54.1</i>	<i>49.2</i>	<i>45.1</i>	<i>41.6</i>	<i>38.7</i>	
127 x 76 x 13	Plastic	83.8	23.2	158	119	92.6	74.1	<i>61.7</i>	<i>52.9</i>	<i>46.3</i>	<i>41.2</i>	<i>37.0</i>	<i>33.7</i>	<i>30.9</i>	<i>28.5</i>	<i>26.5</i>	

Section classification given applies to members subject to bending about the x-x axis only.

Loads given are the total Ultimate factored uniformly distributed load supported over a beam span L assuming full lateral restraint to the compression flange. Self weight of the section has not been allowed for.

UDL values in bold type are governed by the shear capacity.

The unfactored imposed load is assumed to be 40% of the ultimate load given. Unless otherwise indicated, it is only necessary to perform deflection checks if the ratio of unfactored imposed load to dead load is greater than 1.556.

UDL values to the right of the zigzag line in italic type may be susceptible to serviceability deflections > L/360 and so should be checked under imposed loading. (This deflection limit is for beams which carry a brittle finish.)

Blue UDL values may be susceptible to serviceability deflections > L/200 and so should be checked under imposed loading. (This deflection limit is for beams which do not carry a brittle finish.)

For explanation of tables refer to the Handbook of Structural Steelwork - 3rd edition

CHAPTER 3

Single Storey Buildings

By Richard B Barrett, Managing Director, Barrett Steel Buildings Ltd

1 Introduction

Single storey buildings are by far the largest sector of the UK structural steelwork market, representing nearly two thirds of total activity. These buildings are typically used for workshops, factories, industrial warehouses, distribution warehouses, and retail warehouses. Referred to colloquially as "Sheds", sizes vary from small workshops of just a few thousand square feet up to distribution warehouses covering over one million square feet. Similar construction techniques are used in all these buildings, the roofs clad with insulated profiled metal cladding. Industrial type buildings usually have relatively simple elevations, with metal cladding panels, either full height or down to a brickwork dado wall. Retail developments and other statement projects tend to have much more complex elevational treatments, incorporating various materials and features, and using combinations of cladding panels with different orientations, profiles and colours.

Relative sizes of Steelwork sectors in UK

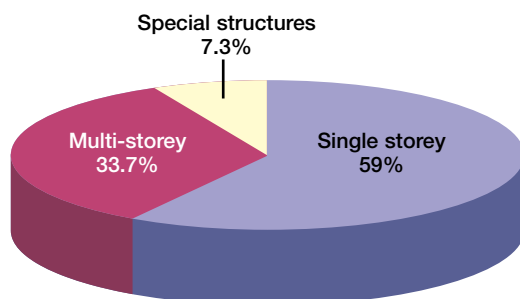

Although described as single storey buildings, in almost all cases there will be offices incorporated into the development. These are typically two storeys high, either within a corner of the building, or attached to the front elevation. The office floor area is usually about 5% of the total area, but can be much higher depending on the client's or tenant's requirements.

2 Procurement Routes

There are two procurement routes for single storey buildings:

2.1 Design & Build

In this context 'Design & Build' refers to the steelwork contractor's role in designing, drawing, fabricating and erecting the steel structures, rather than the type of Main Contract, which could be traditional or Design & Build.

The work is carried out to a Performance Specification that normally includes information such as an outline of the project, architect's drawings, loading requirements, time to first maintenance for painted steelwork, and descriptions of other trades such as cladding materials and industrial doors.

A number of steelwork contractors specialise in this market, and they are able to produce very economical frames, with short lead times, and fast erection periods. Detailed knowledge of steel availability and relative costs, means that economical frames can be selected, purposely designed to suit the specialist steelwork contractor's own production facilities, and to make site erection safe and efficient.

Due to the competitiveness of this procurement route, it has become more and more popular in the UK in recent years, so that it is now by far the most common approach, with at least three quarters of single-storey buildings constructed using Design & Build.

2.2 Traditional

The alternative to 'Design & Build' is the traditional approach, with the structural design being carried out by a consulting engineer working for either the client or the main contractor. The consultant also prepares the steelwork general arrangement drawings, showing all the key dimensional information. Once designed and drawn, the steelwork is tendered to steelwork contractors. The contract will include for connection design, detailed fabrication drawings, fabrication, delivery and erection. This procurement route is sometimes chosen because it gives greater perceived control over the project, although it is rarely going to achieve the competitive edge available through the 'Design & Build' route.

In the remainder of this chapter, in view of its popularity, it is assumed that the project is executed as a Design & Build steelwork contract.



Multi-span portal frame during erection

3 Structural Framing Options

3.1 Portal Frames

The vast majority of single storey buildings are portal frames. Portal frames were first seen in wide use in the 1960s. During the 1970s and early 1980s they developed rapidly to become the predominant form of single storey construction. Using plastic design techniques first developed at Cambridge University, for spans up to about 50 metres they are the most economical framing available. Large column-free areas can be achieved at relatively low cost. Often on multi-span frames the intermediate valley columns are omitted so that on, say, a 45 metre span frame, with bay centres of 8 metres, each column-free box covers an area of over 700 square metres, which is nearly a fifth of an acre!

Most portal frames are manufactured using Universal Beams. On these 'parallel flange' frames, a 'haunch' is formed in the rafter in the highly loaded area adjacent to the columns, using either split a Universal Beam or steel plates, welded onto the lower flange of the portal rafter.

A small number of steelwork contractors offer portal frames made wholly from plates, to form a tapered rafter section, which more closely follows the load profile on the steel. The extra fabrication cost is offset by savings in the material content of the resultant frame. However, overall this form of frame has not been successful in the UK, mainly due to the efficiency of steelwork contractors offering parallel flange frames.

Sophisticated computer software is widely available to design portal frames to the optimum efficiency. These programs use plastic or elasto-plastic design techniques, and can handle multi-span frames with varying geometries and multiple load cases. Design is normally carried out to BS 5950-1: 2000, with loads taken from the relevant British Standard.

3.2 Lattice Girders

The main alternative to portal frames is lattice construction. Lattice frames are generally more expensive for routine applications and spans. However, for certain applications they will offer the best framing solution, such as: for very large spans (say greater than 50 metres), for production facilities needing heavy plant suspended from the roof area, or where deflection criteria are particularly critical.

The main booms of the lattice girder are usually either rolled sections such as Universal Beams or Columns, or alternatively Structural Hollow Sections. The internal members can be angles, beams or hollow sections, depending on the design loads, configuration and fabrication costs.



High bay, large span lattice girder roof

3.3 Cold Rolled Steel

One feature of single storey buildings is the relatively high percentage of the steelwork that is cold rolled. Roof purlins for supporting roof cladding sheets, and side rails supporting vertical cladding are available as proprietary products from a number of manufacturers, for incorporation into the steelwork project. Although these items are very light, weighing only a few kilograms per metre, they typically account for 15-25% of the total weight of the steelwork. There are many more pieces to erect in the cold rolled steel than in all the hot rolled (main) steelwork put together, and therefore this element of the erection needs to be carefully planned and controlled.

4 Geometry and Layout

Column positions may be restricted to suit the layout of equipment inside the building, such as racking in a warehouse, or machinery in a production unit. A good understanding of the relative cost of different span and bay centre options is critical to achieving an optimum layout of the building. Good advice can be obtained from steelwork contractors specialising in the single storey market. This advice should be sought, to avoid critical layout decisions being made without full regard to building economy.

On developer-led projects, the area of the building, usually still given in square feet, is particularly critical. Care needs to be taken to understand precisely the allowable floor area; examples are that it could be the dimension overall the columns, inside of blockwork or inside of cladding.

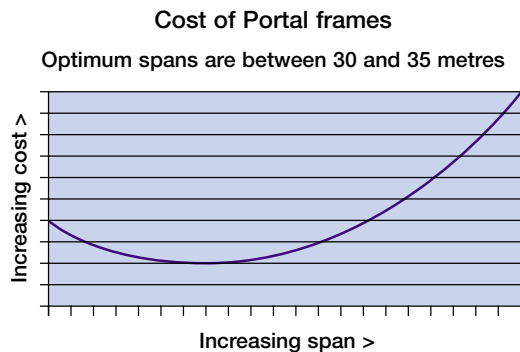

The graph shows the effects of increasing spans on economy of a portal frame building. With increasing spans the cost falls gradually to a minimum at a span of around 30-35 metres. Above this level costs start to escalate quickly. Similar graphs can be produced for differing bay centres and height combinations. The range of combinations escalates quickly, and the steelwork contractor will need to run a number of alternative designs to identify the best layout. Alternatively, the author's own business has set up a website, www.e-asybudget.co.uk, which enables the user to run multiple layout options and gain comparative costings in a matter of minutes.

The height given in the performance specification should normally be specified to the underside of the roof steelwork, which in the case of portal frames is the underside of the haunch at the point it meets the column. This is the clear height required by the building's operator, and allows the steelwork contractor to design a frame to clear this level, the top of the column being determined by the total depth of the steelwork in the haunch area.

Column bases are typically set about 450mm below finished floor level, although this may vary on sloping sites or to suit door details.

The layout and design of the structure will also need to take full account of the required speed of erection. Decisions made at this stage will have a key impact on the number of work fronts available to the erectors, so the overall layout of the building may need to be changed if a particularly quick site programme is envisaged.

As a guide to steelwork sizes, on a typical 36m span multi-span frame, with a height to underside of haunch of 12m, you might see portal rafters 457mm or 533mm deep, the portal legs 686mm deep and a total steelwork weight of about 35 kg/m².

5 Construction Periods

5.1 Lead-in Times

The period from receipt of instruction (letter of intent or order) to arrival on site varies depending on project size, complexity and the industry's workload levels. As a guide, for a typical small or medium-sized shed (up to 100,000sq ft) a lead-in of 8 weeks would be normal, extending to 10-12 weeks on bigger projects. These periods can often be improved if especially required on individual projects, by discussion with the steelwork contractor.

5.2 Site Erection Periods

The speed of erection will depend on a number of factors:

- Number of erection gangs – an erection gang usually consists of 3 or 4 men, with a crane and mobile elevated working platforms. As a rule of thumb, working an eight hour day in reasonable weather, a gang will erect about 50 tonnes (hot and cold rolled) per 5 day week. This is roughly equivalent to an area of 1,500sq m (15,000sq ft). The overall speed of erection will depend on the resources available to the steelwork contractor in terms of speed of the supply of steelwork to site, the number of erection gangs at his disposal, and the number of work fronts that can be safely and efficiently worked concurrently.
- Time of year – in the depths of winter daylight hours are restricted, and it is not possible to work the same number of hours as in the summer months, when it may be possible for the erectors to work much longer days.
- Weather – the programme needs to build in a sensible allowance for weather, based on the time of year planned for erection of the steelwork.
- Site conditions – the planned programme will not be achievable in the absence of well prepared and safe ground. Even if deemed safe for work, poor ground will result in a serious loss of productivity for the erection process. This important aspect is developed further in the section below on Safe Site Erection.
- Site planning – fast programmes will require large lay down areas so that steelwork can be delivered and offloaded in the desired location prior to the erection gang reaching that area.

6 Co-ordinating the Supply Chain

Another key determinant of success is the quality and timeliness of information. To achieve a quick lead-in and efficient working, it is necessary to have other major subcontractors appointed at the same time as the steelwork sub-contractor.

The main contractor has a major role to play in co-ordinating this part of the process. The interfaces between steelwork, roof and wall cladding, doors, glazing, pre-cast units etc will all need to be agreed. On a short lead-in project (say eight weeks or less), these dimensions will need to be finalised in the first two weeks. The recent amendment to the Building Regulations Part L, requires particular care in preparing 'robust' details around the key interfaces in the external envelope to minimise heat loss and air permeability. Careful detailing and complete co-ordination of the steelwork and cladding contracts is necessary to achieve these objectives.

Many main contractors are addressing these issues by establishing a Strategic Supply Chain, selecting a small number of sub-contractors in each of the major specialist areas. By encouraging team working between members of the supply chain, it is possible to capture learning on one project and use it successfully on the next. A well run supply chain will result in greater efficiency of all its participants, producing better quality and lower costs as the team develops.

A series of quick-fire "Design Team meetings" in the critical early weeks, called and chaired by the main contractor, is the best way to co-ordinate the project design. All major specialist sub-contractors need to be present, together with the architects and other relevant professionals. When time is pressing, it is usually most effective for the key decisions to be taken at the meeting, rather than left to future meetings or for subsequent development.

7 Project Management

The preparation of the detailed build programme for the overall project is normally the responsibility of the main contractor.

Most single-storey buildings now have 'fast-tracked' programmes. In the case of steelwork, this means that following trades such as roof and wall cladding, brickwork and doors will be starting whilst steelwork erection is progressing further down the building. To achieve this type of programme, it is necessary to have a series of sectional handovers of the steelwork, at say two week intervals down the building. Each section is fully erected, and then lined and plumbed. After checking and approval by the main contractor, the steelwork bases are grouted up, after which the following trades can commence.

The build sequence at major interfaces is particularly important for the steelwork contractor. For example, the base of the door posts may be bolted to a pre-cast concrete ring beam. Ideally therefore the ring beam should be in place before steelwork erection; otherwise it will be necessary to leave out the door steelwork and associated sheeting rails until the ground beams are fixed. Careful planning and good design co-ordination will in most cases eliminate the need for steel components to be omitted, allowing the programme to proceed smoothly. However, in some cases, a second fix of steelwork will be unavoidable. It is essential that these cases are clearly identified in advance, and allocated a suitable duration in the build programme. The steelwork contractor can then organise erection labour accordingly, and may choose to keep the second fix steelwork off-site until required, avoiding site loss or damage to the un-fixed components.



Erection taking place on four work fronts, with steel lay down areas for each gang

8 Safe Site Erection

A subsequent chapter is devoted to Health and Safety. The comments here are therefore restricted to those issues specific to the safe erection of single storey buildings.

Access is by Mobile Elevating Working Platforms (MEWPs), often referred to as "cherry pickers". MEWPs offer the ability to safely access all areas of the structure, but their success is critically dependent on the ground conditions. When fully extended, a 60 foot MEWP will exert a greater ground bearing pressure through its tyres than a 25 tonne crane through its pad! Badly prepared ground will deteriorate rapidly once a MEWP begins to move over the site. It is therefore essential that the main contractor designs and prepares the ground to take these loads. Drainage needs to be provided so that the site can cope with heavy rain without turning to a slurry of mud. In these circumstances, obstructions in the ground will be concealed, making it unsafe for MEWPs to operate.

Normally the whole of the area of the building footprint will need to be prepared for MEWP and mobile crane access. Additionally, to fit the cold rolled side rails, a three to four metre wide strip for MEWP access will need to be provided around the external perimeter. If it is necessary to fit the rails from within the building perimeter, this will certainly slow erection and incur extra costs.

In bad weather the foundations will fill with water. Consideration needs to be given to how the bases will be lined, levelled and grouted, either by providing drainage or regularly pumping out the bases.

Before commencement of erection, the steelwork contractor will ask the main contractor to complete and sign the BCSA's Safe Site Handover Certificate. This essential document sets out in a checklist form the matters needed to ensure a safe site for steelwork erection.

9 Summary

Whilst most single-storey buildings are relatively straightforward building projects, increasing levels of specialisation by steelwork contractors and other supply chain members have led in recent years to huge improvements in quality, cost and delivery performance. These improvements have been achieved through increasingly efficient use of the portal frame by design and build steelwork contractors, improved project planning, and active supply chain management by main contractors. This chapter has set out in detail these initiatives. Individually, these ideas can have a major impact on an individual project. Applied collectively over a series of projects, they transform the performance of this important part of the construction sector.

CHAPTER 4

Multi-Storey Buildings

By James H Mathys, Director, Waterman Group Plc

1 Introduction

The last century has seen the increasing need to provide space using multi-storey solutions. In the early days steel framing supporting floors of insitu or precast concrete was a popular solution. However in the post 1945 war years the knowledge, understanding, and familiarity by designers of reinforced concrete meant that concrete became the preferred solution for the next 35 years.

By the late 1970s a mood developed to provide a more efficient and more design-conscious construction process than had been experienced hitherto, and this occurred during a time of change within the world of commerce with the advent of information technology. Whilst some buildings had incorporated air conditioning, it was the increasing use of IT and the building services needs this generated, that created the widespread use of false floors and false ceilings that sandwiched and masked the structure. Prior to this reinforced concrete of flush soffit construction that could receive plaster and decoration direct to the soffit had predominated. With more intense servicing generally disposed over the whole floor plate and false ceilings to hide this, the opportunity to provide downstanding construction giving more depth and leverage and hence economy returned.

From the early 1980s we entered the era of the composite steel frame supporting concrete slabs reinforced by the surface bonded steel decking sheet rather than the embedment of rod reinforcement. The provision of insitu through-deck shear studding provided further significant economy to the steel beams and produced a construction process which totally eliminated shuttering and propping, ie construction efficiency through avoidance of material and man-hours spent on the temporary works previously needed to create the permanent project. This process of offsite prefabrication of steel parts assembled at site produces a quality solution, more dimensionally accurate, with reduced programme risk, which with the addition of the insitu poured concrete slab provides a plate diaphragm connecting the whole together without a loss of unity and robustness so often experienced with other prefabricated frame answers.

On maturity of the over-deck concrete, an easily created composite section results to both the slab and supporting beams, the efficiency of which is a significant improvement on steel frames formed of independently designed parts or frames formed of

insitu cast reinforced concrete. The resulting construction depth is less than that of traditional steel frames, and in structural terms we have obtained the greatest strength to weight ratio currently available, thus providing architectural opportunities to design more adventurous buildings of greater interest in their form, and the potential to give economic designs providing large internal clear span space. To use a motor transport analogy, modern composite steel has crossed the line where the payload (load applied onto structure) now exceeds, for whatever span we choose, the weight of the transport vehicle (structural dead load). This marriage is a massive move forward in structural efficiency, and achieves the best of both worlds from concrete and steel.

2 Form and Concept

The ever increasing desire to seek, in the widest sense, designs and products of improved quality at better value requires an understanding of where significant worth lies in the total design and construction process.

It is a fact that the greatest opportunity to achieve value for money is at inception, but some of this value at this earliest stage is subjective, particularly the value attributable to aesthetics. There are, however, some guiding rules that, if matters of planning and aesthetics allow them to be followed, will inherently help greatly in providing best value. It should not be forgotten that this greatest achievable value starts with the determination of the form and concept, and that this opportunity to achieve best value diminishes as we progress from inception to the final "nuts and bolts". This is not to say that best value should be ignored at the latter "nuts and bolts" stage; rather, that the ultimate best value is the sum of applying best value culture to all stages, but accepting that quantum of return diminishes through the process.

Distilling this to the major points, we must acknowledge that once a market quality of the floor space has been established this is a "given", and obtaining best value is not a tampering with component quality and the cost thereof, but maximising value from the variables that produce the desired area of floor space at the given quality.

The façade skin enclosing the building is a major cost component and examined idealistically we can enclose the greatest area (ignoring the lesser practicability of circles) by a square plan form, hence this form yields

best cladding value, ie most floor area with least cladding, giving the least cost per unit area of floor attributable to the external skin. For typical UK building heights, and for efficiencies of servicing, vertical transportation, and the structure itself, the most efficient building form tends to be a cube. Such floor space however will have large distances between walls, ie it will be deep space. Conversely, at the other extreme a long thin building will have the worst proportion of skin cost on the floor area, but has the quality of shallow well-lit space. Adjusting the optimum cube to incorporate an internal atrium with lower cost non-weathering walls adds internal daylight and gives a racetrack of floor space to the desired floor space width. This is not an advocacy that all buildings should be cubical – but to have a realisation of the optimum when designing, as shown in the illustration.

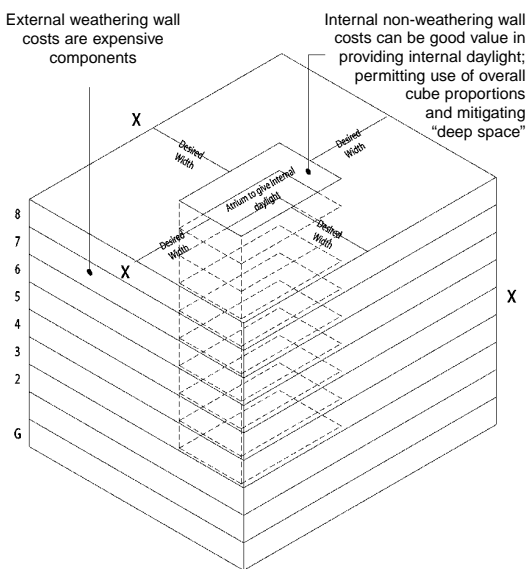

Ideal cubic form to give least wall cost to floor space created.

Building height is a cost variable that is determined by designers by the sum of all the individual components that contribute to the floor-to-floor dimension, namely: the desired finished floor-to-ceiling dimension, the depth of access floor for cable distribution, the desired column spacings and hence beam depths together with the dimension needed for building services and false ceilings. All these should be chosen to achieve the minimum depth required to achieve the individual function with efficiency acknowledging the fact that an unnecessarily loose dimension will add to the storey height and to the cost of every vertical component of the building, ie structure, walls, cables, pipes, lifts, cladding, etc.

Time is a major cost component of a project and has two aspects:

Building life span

The resulting building should be of a concept that is sustainable not only in its material durability needed to achieve the design life, but in its design

style and dimensions to be a visually pleasing and useful building as far as is predictable throughout its design life, ie avoid repeating premature rebuilding as occurred with 1960s buildings in the 1990s attributable to dimensional limitations for re-use. A less than 30 year life is not normally economically or environmentally sustainable.

Construction period

During design every component before being specified should be assessed for site construction time to assist in optimising the build rate overall. Care should be taken not to prejudice the building's overall life span by adopting solutions that simply maximise the build rate, nor should the design for speed of one trade component be at the expense of another such that total time is compromised.

Much assistance in optimising the construction period is achieved by disengaging interfaces between parts, particularly at design stage, eg with steel frames and prefabricated cladding a designer can avoid the time critical interfaces for cladding attachment by fixing cladding to the slab concrete rather than perimeter steel. Cladding fixing information to concrete can be required many months later than cladding fixed to steel where such information is required in time for steel fabrication. Firm and final cladding information is often only available much later than when the steelwork information has been finalised.

3 Foundations

The structural frame and foundations thereof are typically in the range of 15 to 25% of the cost of the whole building. However the safe and serviceable performance of this is essential to the whole investment. Malfunction of the non-structural 75 to 85% may be inconvenient and disruptive but any malfunction of the lesser cost structural and foundation component affects the whole investment. Foundations therefore carry everything, they are the most intensely loaded part of the structure, and almost impossible to inspect later, yet they are the part that transfers the building load to natural strata, the strength and vagaries of which are outside our control. It is therefore of prime importance that foundations are conceived and designed by experienced professionals, and installed by competent trade contractors, to ensure that they transfer building loads to the strata without risk of failure; and that the inevitable minor movements upon load application are of a magnitude that permits the building to function without distress.

For multi-storey UK buildings, the common foundation types will be piles, pads (reinforced [RC] or mass concrete), RC strips, and rafts.

Pads and strips tend to be used on higher bearing strata or where loads are low; rafts where soils are low in capacity, or where other constraints exist or are proposed, such as underlying tunnels or services. Piles have now improved in value and are frequently used for multi-storey buildings, particularly where modern installation techniques using single large diameter piles facilitate the incorporation of the first lift of steel with pile construction. Whilst this is most efficient for construction progress, it does require careful design and planning. The big gain in adopting this "plunged column" technique is the opportunity given to commence steel erection soonest, and leave behind all the usually more complex construction associated with the ground floor and substructure. This technique can be particularly useful where buildings have two, three or more basement levels, enabling the frame to progress upward with some or all bulk excavation yet to occur, but careful planning of the logistics of "muck away", ventilation, etc must be undertaken to optimise the time benefit (hence cost) against the aggravation of excavating through the proceeding permanent works installation. It usually occurs that maximising uninterrupted "blue sky" excavation is best, with only the residual amount of excavation left to be "top down". Benefits in controlling soil heave in deep basement construction are also worthwhile with the "top down" techniques.

Thus, whilst on a pure cost of material basis, pads and strips are often more economic, the increasing popularity of piling is due to the advantages that can be gained by single piles with plunged columns enabling significant overlapping of substructure and frame construction to save on time cost, which is so often more worthwhile than adopting conventional foundations requiring traditional bottom up construction. The following photographs, taken on the same day, show the degree of construction overlap achievable.

Three photos of 59-67 Gresham St on the same day



Deck bundles delivered to 6th; 5th floor decked; 3rd concreted. Cladding to 3rd floor.



Sub-basement blinded, piles to be trimmed for stanchions to support first basement perimeter bays yet to be built.



5th Floor decking laid prior to concreting (3rd concreted).

4 Substructure

Multi-storey buildings usually being in high land cost metropolitan areas often extend downward for the same reason of maximising value on a given land plot. Whilst such substructures often house functions that would otherwise take up more valuable above ground space, ie storage, plantrooms, and parking, they can use atria (refer to concept and form) to bring daylight into a below ground level and increase the floor space that produces revenue, (as in Standard Life's building at 10 Gresham Street, London shown in Foster and Partners' illustration).

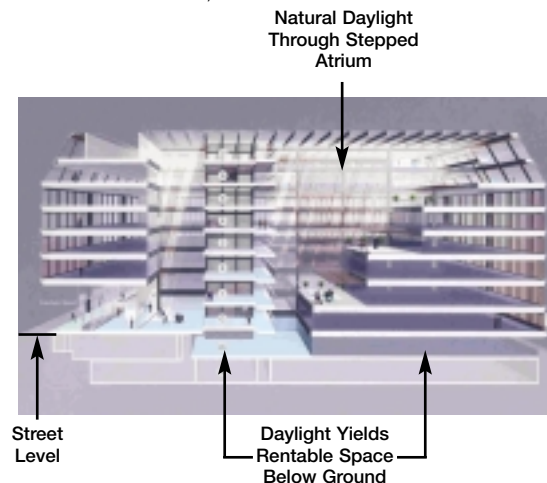

Substructures must be considerate of adjoining buildings and the sensitivity of these to movement, particularly if the adjoining buildings are to be undercut by the proposed excavation. Ground water levels are a major consideration, and it is necessary to determine the style of the perimeter retention system whether it is temporary or permanent, for cutting off the water seepage both to facilitate construction and to avoid dewatering consequences on neighbouring buildings. Substructures need to be watertight, and various qualities of watertightness are defined in BS 8102 for the various intended uses of the space.

The dimensional relationship of the multi-storey frame over the substructure needs careful consideration, particularly around the building perimeter, as it is natural economics that the building above ground will extend to the site boundary but details of below ground perimeter retention may determine that the steel frame below ground is inset. Alternatively, such geometric details may restrict the style of perimeter retention to systems that are capable of carrying the perimeter column loads, ie bored pile walls or diaphragm walls. If this type of solution is adopted the differential movement between perimeter columns sitting on a continuous embedded wall to that of the columns to the first inward grid needs to be limited as part of the design analysis. The dimensional positioning of all parts of the substructure needs to allow for the opportunity to raise the steel frame independent of the more complex and slower construction rate of the substructure construction to gain the big economies of time cost. Alternatively it is often possible to design out complex retention systems and avoid boundary underpinning by adopting inwardly stepping profiles to the substructure boundaries as illustrated.

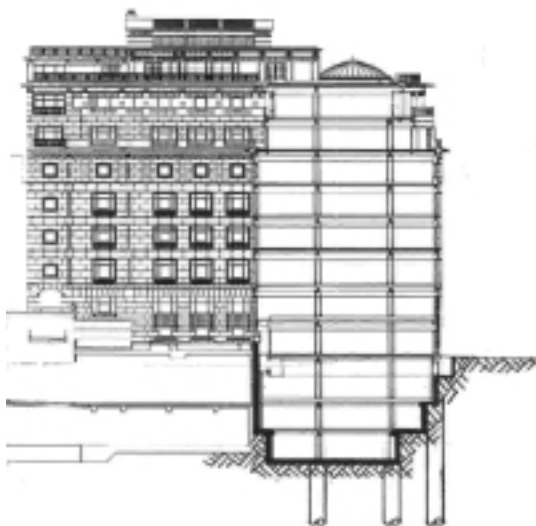

Three level basement at 55 Bishopsgate showing stepped retention system to Bishopsgate elevation.

The costs of excavation, dewatering and perimeter retention systems are significant, and designers should conceive the structure at ground floor and below to minimise the depth of the substructure. Whilst the main steel frame above ground may enjoy the benefits of large spans giving the column free highly serviced space afforded by composite steel solutions, the on cost below ground of going deeper than necessary must be appraised. The writer has found that the subdivision of a large span superstructure is an appropriate best value answer for the lesser serviced substructure. Doing this produces construction depths to the ground floor and other below ground suspended floors of far less depth than on the superstructure. Such depth savings can easily exceed half the construction depth of that for the superstructure by using "Slimflor" or RC flat slab construction and on a two level substructure this can save from the three construction layers about 1000 mm on the bulk excavation, depth of retaining walls etc and will mitigate dewatering or even avoid entering the groundwater.

5 Superstructure Floor Construction

Before determining the form of construction to be adopted for a particular project the designer has a duty to his client to review all appropriate options. This is best achieved by producing a formal "Options Report" stating the various pros and cons of each option for the proposed development.

The key points to consider are:

- The site constraints and the architectural solution to these.
- The building users' needs and the required floor spans.
- Economy – Which option can produce the optimum cost and value?
- The building services intent and how best to incorporate them into the structure.
- Construction time – What are the time differences between options and what are their different risks to the certainty of timely delivery?
- Building height constraints due to Rights to Light, historic view lines, and general planning limitations.
- Foundation complexities that may be eased or exacerbated by the various options.
- Detail aspects; ie is a particular option a "natural" solution to a detailed requirement.

Every building is different and there will be different cases where steel or concrete frames are the "natural" answer. However, the low dead weight of modern composite steel frames giving a high strength to weight ratio makes steel advantageous on many of these key

point headings. This lesser weight building answer is also often a useful attribute on sites of archaeological interest where the intensity and size of the foundations can be shown to be the least intrusive as a consequence of the light frame.

In its simplest form the composite frame comprises universal columns supporting plain UBs traditionally laid out in the primary and secondary manner. These are overlaid with an indented profiled metal deck through which shear studs are welded through the deck to the top flange of the beams on site. As a process this achieves great construction efficiency as it totally eliminates all the temporary works associated with other solutions by the steel itself carrying all the wet weight of concrete during construction in a simple non-composite mode. Upon concrete maturity the composite mode develops to both the deck slab and supporting beams to carry the service design load of the building. The simplicity of simply-supported design permits the simplest of fastenings to occur at end connections and results in only static loads being transmitted to columns and foundations, ie the total static load of the whole building is that carried by columns and foundations whilst an RC design that naturally benefits from design continuity the load on columns and foundations has to respect pattern loading such that loads on columns must include a load for elastic continuity, such that the design load carried on columns and foundations then exceeds the load of the total building. This compounds the fact that most commonly-used concrete solutions are heavier than those of composite steel.

Steel solutions have evolved from the simplest UB solutions, with services in a separate zone below the beam soffit, to larger span solutions with iterations involving tapered beams, stub girders, lattice girders, Cellform beams, and Fabsec beams. The ability to provide economic asymmetric beams with infinite variety of depth and breadth with any pattern of web holes for service penetration has come about by the fully automated computerised fabrication processes now available, and has given the ability to provide exciting and adventurous composite solutions in an affordable way.

The earliest tightly-gridded composite steel buildings produced shallow beam depths, precluding penetrations of sufficient size to accommodate service ducting. The interest and growth of larger spans has been popular in improving the quality and utilisation of the floor space because of increased flexibility. By adopting larger spans the fewer number of deeper members gives space for more frequent and larger penetration opportunities that allow integration of services for the base build design (as illustrated), and for future upgrades throughout the design life of the building.



10 Gresham Street has 18 m clear span floors throughout, with all service penetrations through the beams with large over-provision for change.

As well as being more service friendly, the larger span solutions significantly reduce the number of parts, producing savings on drawing office and fabrication costs, with the on-site benefit of fewer connections, less crane hook and general erection time to fix. The extra cost is in the raw steel component, and whilst these larger spans usually cost a little more, the cost mitigations derived from fewer parts often yields larger spans as a best value answer.

The past 15 years has seen the adoption in commercial buildings of lower floor loadings from the historic market norm of 4 to 5 kN/m² + 1 kN/m² for demountable partitions to 3 to 3.5 kN/m² + 1kN/m² for partitions. The principle has been to adopt these lower loadings over 95% of the floor plate whilst significantly increasing the capacity of the remaining 5% at structurally convenient locations which produces a more usable answer at less cost. This design brief imposed load reduction has yielded steel answers leaner than before, ie less metal, but therefore of less stiffness, which together with the increasing spans, has made the floor construction more susceptible to vibration, in particular that from footfall vibration from people within the building. Guidance on design for vibration control is given in SCI documents and BS 6472 and a good understanding of these is an important aspect of frame design, particularly when beams are penetrated by large rectangular holes allowing secondary influences on bending, deflection and vibration to occur. The writer has found that very large spans of 18 m and more are not necessarily the most vulnerable and attributes this to the larger area of floor and hence mass to be accelerated, and judges that spans in the range of 10.5 m to 16.5 m to be more vulnerable.

Fire protection of steel floor construction has evolved from concrete encasement, through fibrous sprays, quilts, dry board to the now affordable painted intumescent coatings, which have the advantage of being applied at the fabrication works. All of these are essentially insulants to defer the time at which the steel temperature reaches a critical level affecting structural performance. The unprotected steel deck, which is effectively the tensile reinforcement of the slab, avoids the need for applied protection as these slabs are

justified by design of the concrete embedded mesh reinforcement acting in catenary at the ultimate fire stage and this behaviour has been verified by fire tests. The aim of such fire protection as required by the Building Regulations is to ensure that the building "...shall be designed and constructed so that in the event of fire, its stability will be maintained for a reasonable period". Such time periods normally range from 30 to 120 minutes and depend on building use, height of building, and whether or not the building has sprinklers.

6 Building Services Integration

As few buildings can afford the height (planning and cost) associated with keeping separate zones for structure and services within the ceiling space, the passing of services through the web of the steelwork is a workable compact answer that creates an intimate interface between the frame and services that is fundamental to structural design. Alternatively overlapping zones can occur by using haunch ended composite beams or tapered composite beams, and again such service positioning and size is fundamental to the structural design.

Typical storey height components for current commercial buildings

Raised floor zone	125 to 180 mm (more for financial trading floors, often 300 mm)
Structure/services zone	700 to 1100 mm
Ceiling & lighting zone	90 to 150 mm
Clear height	2600 to 3000 mm
Total storey height	3515 to 4430 mm

As illustrated below, the structural zone in the above must allow for tolerances to both steel and concrete and for deflections that occur prior to installing the ceiling and false floors.

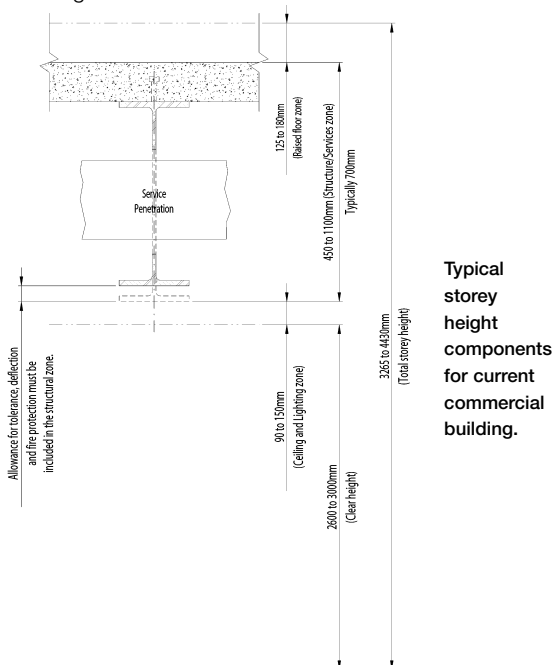

Services that need to be incorporated involve cabling, piping, air ducts and the outlet boxes to these, all of which are easily suspended from the profiled metal deck having an in-built fixing facility to the soffit to avoid on-site drilling for such service suspension.

The most common generic beam/service solutions are as follows:

- i) The simplest and most economic in fabrication terms but is far from the most economic overall building solution as the summation of the depths required for structure and service zones produces the greatest floor-to-floor height solution for the building. It is however the least constrained, interface-free building services solution.

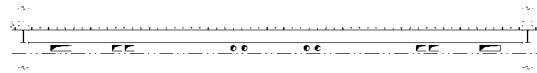

Standard UB with separate services zone.

- ii) A plain composite UB with service holes provided through the web gives a significant saving on floor-to-floor heights. For economy of the steel section, large rectangular holes should avoid being located at beam ends and mid-span. Adding such penetrations to standard sections may require strengthening to the hole perimeter, and a limitation exists on number of holes economically available.

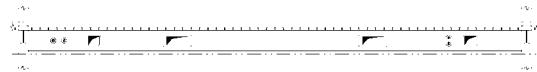

Standard UB with integrated services through web.

- iii) A composite lattice girder with top and bottom chords cut from UBs or UCs can provide answers low in steel weight that provide a high proportion of void space for penetration by services. Triangular spaces are good for circular ducting, piping, wiring and large rectangular ducts can be accommodated in a central rectangular panel provided this is structurally analysed for unsymmetrical loading, ie "Vierendeel" bending. Using inverted tee top booms increases further the penetrable space, but adds further fabrication complexity. Lattice girders are high in fabrication costs.

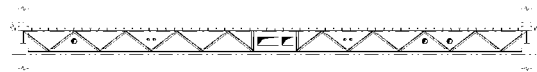

Lattice Girder with large central rectangular services aperture.

- iv) Fabricated tapered beams can provide an overlapping zone solution mixing some benefits of avoiding strict integration of services and structure whilst avoiding total summation of zones in the floor sandwich. Its disadvantage is that the defined service routes on plan may not be ideal and structurally there is a reduction in the inherent stiffness to that of other solutions as the ends "tend" towards a true pin.

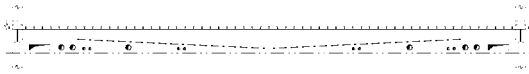

Fabricated Tapered beam with overlapping zones.

- v) The stub girder which is essentially a composite "Vierendeel" girder with very stiff uprights is inherently very sympathetic to penetration by intense servicing by providing large rectangular voids across the span. In its most efficient form the stub girder is used as a primary member receiving point loads from the secondary beams supporting the slab. Best economy is achieved by the opportunity given to design the secondaries as continuous over the bottom boom and the engineer choosing where to splice these, usually between the support and point of contra flexure. Stub girders also have the benefit of being a system that produces two structural zones that can be mimicked by the services to avoid clashes.

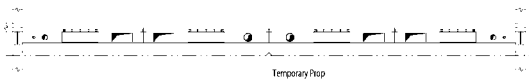

Stub Girder with inherent large rectangular apertures.

- vi) "Cellform" beams have been enabled by automated cutting and welding processes. They are formed from cutting circular profiles in the webs of rolled UB and UC sections cut to half depth and re-welded to provide both symmetrical and asymmetrical sections penetrated throughout by circular holes. Good for multiple circular duct penetration, but not for single large area air ducts.

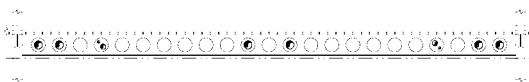

Cellform Beam for many smaller circular services penetrations.

- vii) "Fabsec" beams have again been made possible by automated cutting and welding processes. They are made as any size of I beam from three plates incorporating any specified configuration of holes at an affordable cost. This solution is the ideal method to integrate services through the structure and its affordability enables over-provision of service hole penetrations from the base build requirement to suit changes required through the building life. Ideal for large span composite designs because of the limitless range of asymmetry available, but care to be exercised in not providing too many large rectangular holes, particularly toward supports, as deflection and vibration susceptibility is increased due to this. This solution can be regarded as the industrialised equivalent of lattice girders with improved usefulness for service integration.

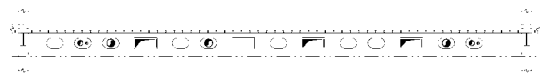

Fabsec beam providing many mixed size penetrations.

7 Lateral Stability

The modern steel frame described largely achieves its quality and economy by virtue of the composite nature of the floor structure, which by definition requires a simply supported approach to beam design. This produces a frame low in inherent stiffness at the beam to column joints such that stiffness to resist lateral loads has to be provided elsewhere.

All buildings must have a structurally defined route by which applied lateral loads, primarily wind, pass down the frame to terra firma, with this impact on design increasing with building height. On low rise and multi-storey buildings to circa 40 storeys, such stability systems have little architectural impact, but for high rise buildings often the most efficient solution is to provide such systems where greatest leverage is available, ie on the façade skin, and is often a driver to the architecture. For most UK multi-storey buildings the best solution is to provide stiff diagonally braced steel elements within the core walls to the circulation, toilets and service areas which occur on every building. These stiff elements are essentially upward cantilevers from the foundation to which all the upper floor plates are attached to gain stability. To be most effective, such stability towers should be symmetrically placed within the building floor plate, but positioning cores is often driven more by other functions than structural stability, and the engineer has to frequently work with cores of dissimilar dimension unsymmetrically placed on the floor plate. When this occurs it is important to recognise the consequence of differential stiffness one core to another, and whilst the lateral load may be adequately resisted, the result of differential deflection

causes torsion on the frame as illustrated. Use of the perimeter beam and column framework around the building is a useful way of controlling such racking and contributing to stiffness.

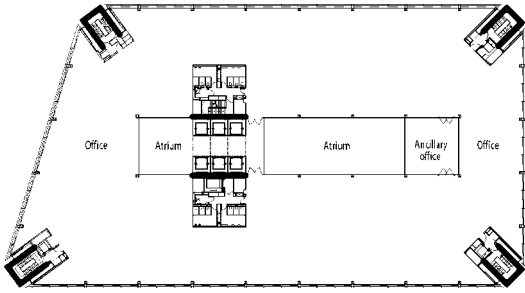

Floor plan of 10 Gresham Street showing totally column free 18 m wide space with almost perfect distribution of stiffness to resist lateral forces whilst providing well distributed entry and exit points to the users.

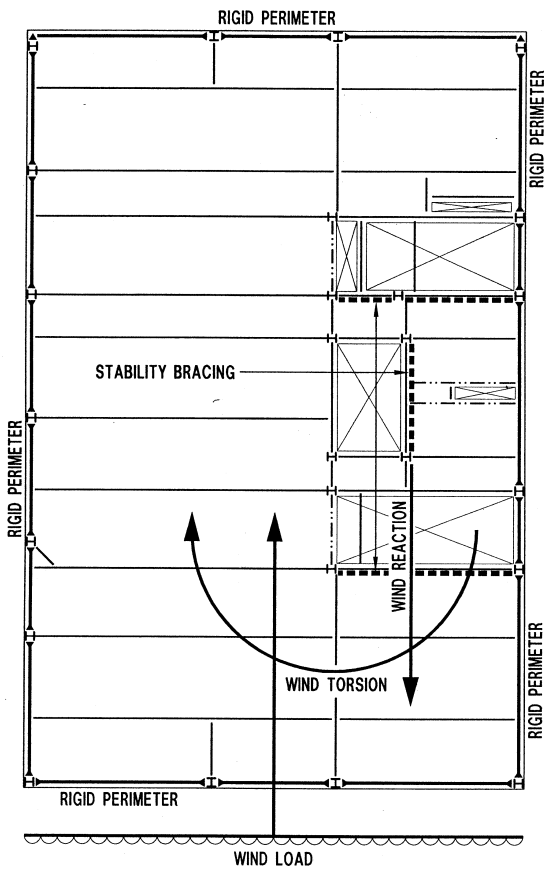

Eccentricity of lateral load action and reaction and perimeter control of resultant racking.

The mechanism of wind reaching the braced cores is:

- wind applied to cladding;
- cladding reacting on floor plates;
- floor plates reacting on bracing.

There is a need for cores to provide vertical circulation (lifts and stairs) for people and for all the vertical service risers supplying the floors, hence there is significant penetration of the floor plate within cores often adjacent

to walls. It is important therefore to check that adequate connection is maintained between the floor plate diaphragm transferring the lateral load and the braced wall that ultimately resists this.

Portalising the frame with rigid joint beam to column connections is an alternative way to provide the stiffness to resist lateral loads but this is less efficient in material use than braced walls, and it imposes fixity on the plain beam and column sections, increasing the beam sizes that would otherwise have been sized compositely as well as adding complexity to the connections. It can occur however that architecture requires a close centre perimeter column arrangement of say 3 m centres, and it would then be opportune to portalise this to provide a stiff perimeter to resist lateral loads. It is always important to keep an open mind and examine the best opportunities arising from each design at concept stage. Whichever solution is adopted it is important to design the stability system to limit the lateral drift of the building to avoid high consequential cost on other components like non-structural walls and façade cladding where movement joints need limiting for both aesthetic and functional reasons. Limits in common use are $1/300 \times$ storey height and an overall maximum at roof level of 50 to 75 mm, but this is variable dependent on the individual building location and circumstances.

Whilst the above refers to steel stability systems, there has been a return in recent years, particularly in centre core buildings, to providing the stability stiffness by using reinforced concrete cores constructed by slip or jump form techniques. Whilst these can sometimes be advantageous, a careful appraisal of the time cost taken by devoting the site initially to reinforced concrete construction which later supports the steel is important, particularly when compared to the rapid progress opportunities available from raising steel from single piles with plunged stanchions, as previously noted under 'Foundations' and 'Substructure'.

8 Robustness

As well as providing safe and sound solutions for the applied design loads whilst being mindful of the use of society's resources, the engineer is to conceive a solution that has the assembly of parts well integrated one to the other, such that they are united in providing a robust whole.

In London in 1968, the partial collapse of the multi-storey residential building known as Ronan Point illustrated the need and importance of an integrated and united whole. In response to post-war housing needs, the building was formed from a standardised prefabricated building system using precast concrete elements. A domestic gas explosion from a kitchen on the sixteenth floor produced an explosive force that

blew out the enclosing load-bearing external wall panel supporting the floor above, together with other similar load-bearing panels up to roof level. The collapse progressed to roof level and the weight and impact of this material on the floors below the explosion floor caused them to collapse also, and the event saw the total collapse of the corner of the building between ground and roof.

The consequence of a relatively small event was a disproportionate collapse, which was identified in having its root cause in a lack of unity between the precast walls and floors at their junction. This resulted in amendments to Building Regulations and Codes to ensure that a sensible degree of unity and robustness of the whole is achieved. Obviously such regulatory requirements are limited to a sensible degree of protection and with the advent of terrorist bombings, there may be some building users that seek more than the statutory minimum.

Distilling the requirements of the regulations they essentially require that the robustness be achieved by the provision of ties designed to prescribed forces to unite all the structural frame parts together. Taking as an example a simple compression member like a stanchion, the requirement is that at a splice there is the capability to achieve a prescribed tension such that if a column storey was removed, those above could hang from the network of beams and columns without collapse, albeit with significant distortion and catenary action of the remaining parts. Where an unusual design makes such tying difficult or impossible to achieve, there is an alternative, more rigorous route to design the elements and assembly to prove adequacy in sustaining prescribed forces.

The current generation of composite steel frames inherently provide much of what is required in respect of ties. In the vertical members the bolts used in standard splices often suffice, and where they do not, there is little economic impact from providing more. On the horizontal floor plate, the beam end connection bolts again usually provide the prescribed ties. Furthermore, the mechanical connection of the steel deck through shear studs and the mesh reinforced overdeck slab provide a superb unification of all the steel parts through the in situ poured concrete slab diaphragm. Whilst currently less common, any designs using precast concrete floors do not have the benefit of the in situ diaphragm and tie forces are best achieved at the steel to steel connections. Fortunately the frequency of gas explosions like Ronan Point, which was seminal in formulating the UK's prevention of progressive collapse requirements, is rare. Unfortunately the threat and reality of terrorist explosions is increasing and the current rules have served the UK well; other countries and international codes are now making similar tying rules mandatory. The writer notes that with responsibilities on buildings in close proximity to the

Bishopsgate bomb, it was noticeable that the composite steel buildings fared relatively well, and attributed this to the benefits afforded by a light and well unified whole, and the malleability of steel to function relatively well with large distortions, compared to the brittleness of concrete.

9 Cladding

Whilst by definition cladding is a non-structural component on multi-storey framed buildings, it does have an impact on several important aspects of conceptual and detailed structural design. The external wall is the important element that keeps wind and weather from the users within and the fabric forming the building. It can range from being a heavy component of brick or stone to lightweight metal and glass, and on multi-rise framed buildings is usually carried at each floor of the frame, either bearing on the floor below or hanging from the floor above.

Conceptually the best overall economy is usually achieved where the cladding cloaks the building outboard of the whole frame, thus avoiding detailing interfaces from complexities of shape between the cladding and structure, thus protecting both the people within and the frame supporting them. Exceptions do exist and good economies of frame and cladding have been achieved on buildings where the frame is expressed totally outboard of the façade with simple repetitive penetrations of the structure through the façade, as illustrated.



Mid City Place, Holborn with fabricated external box columns with rigid box beam spigots through the cladding spliced internally to floor beam.



Fleet Place, Holborn with simple rectangular spigots penetrating cladding with joint to floor beams inside the cladding.

It has evolved that the most useful planning grid for most commercial buildings is 1.5 m and the structural grids respect this at multiples of 1.5 m, with floor beams usually set out at 3 m centres, and columns commonly ranging from 6 m to 9 m on the façade and 9 m to 18 m internally. Potential sub-division of the internal space by partitions to give cellular office space is most common at 3 m and 4.5 m. It follows that the perimeter offices that about the façade cladding create the need for the façade mullion module to also be considerate of the 1.5 m planning module such that potential partition lines neatly about this. Cladding, whatever the external façade material, is now commonly prefabricated and designed at a multiple of 1.5 m. It is the writer's view that the best quality cladding system is where panels extend the full bay between column grids. Doing so minimises the number of site sealed weathering joints and locates them where minimal vertical structural movement exists. As illustrated, panels of 9 m width are often used and have been found to be readily transportable from European suppliers.



10 Gresham Street 9 m wide 4 m high finished cladding delivered from Germany. Rigid units bearing on slab adjacent the stanchions.

However easier transport logistics, and economies of cladding manufacture can mean that smaller component systems are more affordable. "Stick" systems are one such alternative, where a 9 m façade bay would be enclosed with 6 No 1.5 m wide "sticks", each bearing on the perimeter structure with each stick having differential vertical movement to its neighbour due to structural deflection. In so choosing, the designer and client must balance the difference in cost between these systems and the value including design life between them.

Whatever system is chosen it is imperative that all the design movements expected from the structure are provided to the cladding company; the major deformations being:

- deflection of perimeter beams
- shortening of perimeter columns
- lateral movement from horizontal loads

Design of the perimeter structure should respect the fact that it is far more economic, more aesthetically pleasing, and less risk to long term cladding performance to stiffen the supporting structure rather than attempt to design the cladding to absorb large movements. It may also be appropriate that a more economic or more movement prone cladding system requires a stiffer structural perimeter than a full-bay panel solution.

On a fast running project, attachment of the cladding to the perimeter structure can be a difficult information supply interface where preparation of steel fabrication drawings can be many months in advance of detailed information being available from the cladding supplier. Many interface difficulties can be avoided in the construction industry, and in this case a decision to design and fix the cladding to the concrete slab buys several months of design and detail time for the cladder and avoids this critical steel-to-cladding interface. The manner by which the cladding bears on the structure can be most important in avoiding torsion being applied to the perimeter beams. The basic principles of the attachment should be set at scheme design and the cladding load should be applied concentrically to the underlying edge beams.

10 Buildability

Buildability is a word having many meanings, depending on whom you talk to! Designers should only design that which can be built, and with today's knowledge virtually anything can be, but often at some detrimental cost to the important aims we subscribe to, namely: quality, cost, programme, and safety.

What should really be sought is the best of the above aims by "thinking smart" in how design may be constructed with inherent ease. The modern

construction site is now very much an assembly place for prefabricated parts, and this should continue to be further maximised. The modern composite steel frame design is very much an example of this in the manner by which it totally avoids the need of on-site construction to build wasteful temporary works involving man hours and materials to achieve the permanent product. By considering the earlier headings in this chapter, the ideas and methods described go a long way towards making our multi-storey buildings more "buildable" than they previously were.

Examples include:

- Frames that avoid materials and man hours constructing temporary works.
- Stanchions placed by plunging into piles to start steel erection soonest, and bypass the more complex, time-consuming substructure.
- Use of three storey column sticks for fast upward progress.
- Larger spans giving fewer parts for an improved piece count.
- The simplest connections associated with simply supported designs.
- The provision of the permanent staircases at the lead of steel erection for all the workforce to gain safe and sound access to their workplace.
- Steelwork painted at works with intumescent fire protective paint to eliminate fire protection as a programme item in the site works.
- Steel beam solutions like "Fabsec" giving asymmetric answers with a generous provision of service holes avoiding a precise tailor-made answer.
- Solutions that avoid transfer structures.
- Best degree of repetition possible by grid planning and rationalisation.
- Leave decking across floor service holes after concreting to be removed at start of services installation.
- Designing for more realistic lower imposed loadings.
- Minimising by design the depth of sub-structures.

The above improves quality and safety, and enables the frame to reach roof soonest to commence work on roof plant and lift motor rooms at the earliest opportunity.

Having reached the roof soonest, the buildability continues with full-bay panelised cladding fixed onto the slab from operatives working safely and efficiently inside the building, whilst below ground the conceptual substructure framing has minimised the depth to formation of the lowest basement.

What further improvements can be made? The writer suggests that for each element being specified and before committing the answer for that element, designers consider whether or not they have achieved the collective optimum of quality, cost, programme, and safety; can it be created off site for further improvement; and can it be further refined to improve buildability at site.

In summary, a well conceived modern, high strength-to-weight ratio, composite steel frame gives in the widest sense a quality answer enabling affordable adventurous design forms to be built. Adopting well-thought-out construction processes into the design concept achieves build costs that are hard to beat. The off-site fabrication with well-conceived, simple on-site assembly permits an unmatched construction rate with less exposure to risks – both time and safety.

This chapter has been written as a generic and philosophical approach to design where the writer considers the greatest worth lies, rather than being analytical and figurative where much guidance currently exists. Whilst much of the content is derived from the "cut and thrust" of designing commercial buildings it applies equally to other building uses, ie hotels, hospitals, residential buildings etc.

High quality achieved at least cost and delivered quickly and safely is the result, and will always be the demand from our clients, and we should continue to strive for further improvements on today's best.

"It is not cheaper things that we want to possess but expensive things that cost a lot less".

John Ruskin 1819-1900

CHAPTER 5

Design of Connections

By Richard Stainsby, Chartered Structural Engineer

1 Introduction

1.1 Concept

Connection Design is defined in the National Structural Steelwork Specification (NSSS) as "*The design of bolts, welds, cleats, plates and fittings required to provide an adequate load path between the end of a member and the component it connects to*". The connection may be therefore as simple as a profile weld where one component connects to another, but more often will be:

- a plate gusset as in a truss or bracing system or,
- the plate or angle cleat elements which, with connecting bolts or welds, form the means of transferring forces between frame members as in a beam-to-beam or beam-to-column connection or,
- the plate elements used with bolts or welds to connect two shorter components end-to-end to form a longer component, as in a beam or column splice or,
- the plate elements used with welds and bolts to transfer forces into walls and foundations, as used in a column base connection and may include,
- the plate elements used with welds to *stiffen* a component which would otherwise be overstressed in the immediate area of the connection, as column flange stiffeners in a portal frame eaves connection.

An adequate load path for a connection depends upon the design of the component. Where only shear and axial forces have to be transferred between components, and there are no stability requirements, the connection is often referred to as *simple or pinned connection*. However, if bending moments have to be transferred or if the frame analysis depends on continuity of all the mechanical properties of the member, then a *moment connection* will be required.

It must be remembered that the geometry of the connection may have the effect of reducing the capacity of the component it connects. Thus bolt holes in members designed for axial tension reduce the area of the member and therefore its carrying capacity unless some special provision is made. On the other hand struts intended for axial compression are designed to resist buckling at the

mid point of a member, remote from the bolt holes which have no effect on the capacity. When the end of a member has to be notched to facilitate the connection being made it may be necessary to check the remaining section for the forces occurring in the notched portion of the member.

The component design will probably be based upon ideal intersection of centrelines of members. If the connection design introduces an eccentricity between member centrelines the induced moments may have to be taken into account in the connection.

Connections may be required to resist additional temporary forces during erection. Steel frames which are designed to receive stability by walls and floors in the finished structure may require the connection design to take account of stability forces unless temporary bracing members are provided.

1.2 Bolting and Welding

Assemblies made in the workshop can be fabricated using bolted or welded connections, there is little difference in the cost, but some steelwork contractors have a preference for a particular system and this may be reflected in their quotation. If the finished structure is to be highly visible then aesthetics may also be part of the design decision.

Erection of components is generally made using bolted connections because welding on site is difficult when:

- weather conditions cannot be relied upon to ensure the correct environment for successful welding and subsequent testing,
- correct fit-up for welding must take account of erection tolerances as well as fabrication tolerances,
- site conditions make it more difficult to hold components prior to welding,
- some welds in restrained positions will be more liable to fracture unless special steels or welding techniques are used.

It is good practice to use standardised connections where possible. When used, they can be prepared with little calculation, approval is simplified and short cuts to preparing fabrication information can be adopted. Standard

connections for beam-to-beam and beam-to-columns can be found in three BCSA/SCI publications:

- Joints in Steel Construction - Simple Connections (Publication 212)
- Joints in Steel Construction - Moment Connections (Publication 207)
- Joints in Steel Construction - Composite Connections (Publication 213).

These publications show design procedures in detail and give comprehensive worked examples of the design of connections. However, the steps in design procedure for some common connections are given here in section 5.

Other BCSA/SCI publications providing a wide range of data used by the connection designer are:

- Handbook of Structural Steelwork (Publication 201)
- Steelwork Design Guide to BS 5950-1: 2000, Section properties and member capacities (Publication 202)
- Section Properties and Member Resistances to Eurocode 3 (Publication 158)

The NSSS includes the basis for essential specification requirements for steelwork connections in bolting, welding, inspection and other fabrication matters. In its first section, guidance is provided on essential information required for steelwork contracts including that needed to prepare the design of connections.

2 Connection Design

Typical connections are shown in Fig 1; the illustrations show beam/column connections in steel-framed structures. Design procedures for some of these connections are given in section 5 which are in accordance with the recommendations of BS 5950-1. For simple connections, use is made of the Simple design method described in clause 2.1.2.2. of the code.

The analysis of the forces on the connections is made using factored forces. Note that special 'blind fastenings' are needed for bolting to RHS columns. Details of these can be found in Joints in Steel Construction - Simple Connections.

Connections may be designed on the basis of any realistic assumption of the distribution of internal forces, provided that those forces are in equilibrium with the externally applied loads. Keep in mind that an easily understood connection design results in fewer errors and aids efficiency in information preparation, material preparation, assembly, despatch and erection of components. The following rules will help promote this:

- Ensure the design takes account of connections, and see that the design team all work to the same rules.
- The centroidal axes of the connected members should meet at a point; otherwise the effect of the eccentricity of the connection should be taken into account in the design of the members.
- Bolts and welds in splice connections should be designed to carry all forces, except where provision is made for direct bearing where compressive forces are to be transferred by direct contact.
- Rationalise member reactions on design drawings, but make sure that they are commensurate with the member sizes and that forces are in equilibrium at each joint.
- As far as possible only one size and grade of bolts should be used on a project.
- Structures supporting dynamic forces may need full penetration welds; other structures do not.
- The local ability of the connected members to transfer the applied forces should be checked and stiffeners provided where necessary.
- Avoid moment connections which are not concentric with member axes.
- Bolts should generally be bright zinc plated, sherardized, spun galvanized or otherwise pre-treated to be compatible with the paint protection system for the steel frame.
- Where dissimilar metals are likely to be in contact in a moist environment, suitable isolators such as neoprene washers and sleeves should be incorporated to prevent bimetallic corrosion.
- Ensure that the design is complete when the steelwork contract is placed, or provide time for design development.
- 'One-off' specifications cost money. Use the NSSS.

3 Recommended Material and Detail for Connections

The material, bolts and welds commonly used are shown in Table 1. Although member design may often be made using higher grade steel (S355) it is recommended that S275 steel is used for fittings for the connection design. Flats and angles are more easily obtainable in the lower grade steel and material grade errors can be avoided.

Bolts used most frequently are termed 'ordinary bolts'. They are the non-preloaded type and the strength grade generally adopted for main connections is 8.8 with grade 4.6 used for connecting secondary members such as purlins or sheeting rails. They are used in holes with 2mm clearance except for stanchion bases where the greater clearance as shown in Table 1 is used.

Bolts threaded for their full length (which are known technically as screws) are commonly used. They can be provided longer than necessary for a particular connection and can therefore dramatically reduce the range of bolt lengths specified. For example, the M20 x 60mm long grade 8.8 fully threaded bolt has been shown to be suitable for 90% of the connections in a typical multi-storey frame. Table 1 indicates the bolt sizes and lengths regularly used.

Preloaded high strength friction grip bolts should only be used for special cases such as when 'joint slip' between connections must be avoided. They are more expensive and need careful supervision when being installed.

All the welds described in this section are simple fillet welds made by a metal arc process. The standard leg length is 6mm or 8mm, which can easily be laid in a single run. Fillet welds of this size are generally recognised as being extremely reliable and will normally need little testing beyond the mandatory visual inspection.

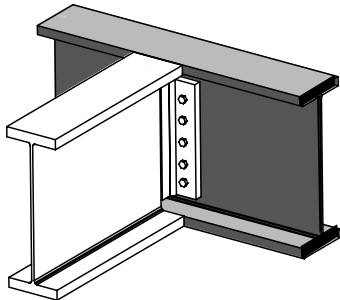

Beam-to-beam Flexible End Plate

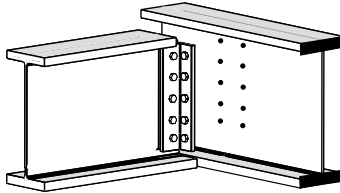

Beam-to-beam Web Cleats

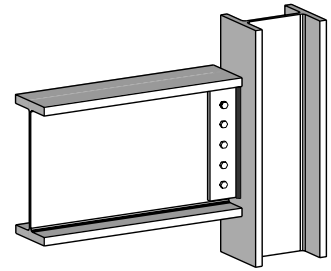

Beam-to-column Fin Plate

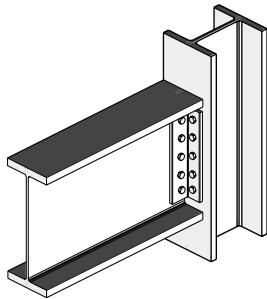

Beam-to-column Web Cleats

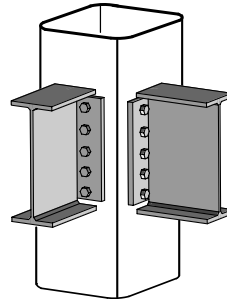

Beam-to-RHS Column Flexible End Plate

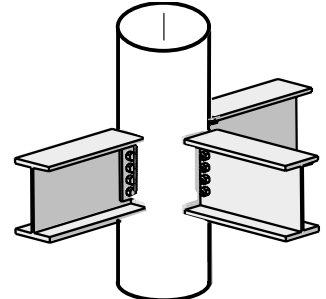

Beam-to-CHS Column Fin Plates

(All the above are designated as Simple Connections)

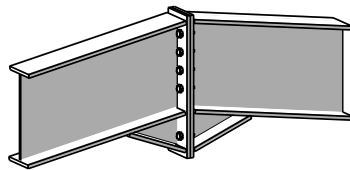

Portal Apex Moment Connection

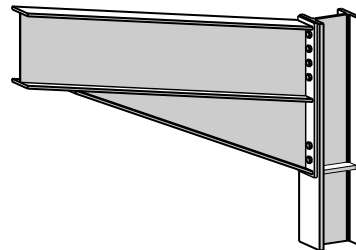

Portal Eaves Haunch Moment Connection

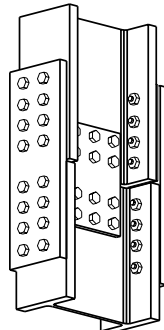

Column Splice

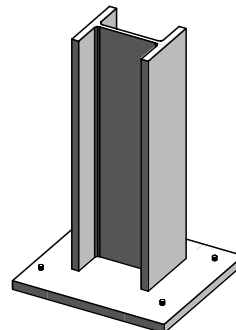

Base Connection

Fig 1 Typical Connections

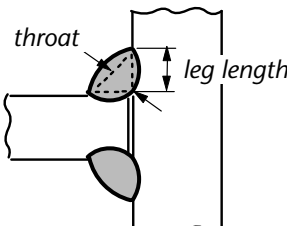
Table 1 Recommended material and detail for connection components		
Component	Preferred Option	Sizes most used
Fittings	Material of strength grade S275	Flats: 100mm to 200mm wide and 8mm or 10mm thick Equal Angles: 90mm x 90mm x10mm thick Unequal Angles: 150mm x 90mm x10mm thick
Bolts	Grade 8.8 Bolts for most common connections Grade 4.6 Bolts for connecting components thinner than 5mm Grade 8.8 Bolts for connecting components of thickness between 5mm and 8mm Grade 8.8 Bolts for connecting components thicker than 25mm Grade 4.6 Bolts for Foundation bolts	Diameter: 20mm Length: 45mm or 60mm (Designated M20 - 8.8 bolts) Diameter : 12mm Length: 25mm (Designated M12 - 4.6 bolts) Diameter : 16mm Length: 30mm or 45mm (Designated M16 - 8.8 bolts) Diameter : 24mm Length: 70mm, 85mm or 100mm (Designated M24 - 8.8 bolts) Diameter : 24mm Length: Sufficient to ensure that 20 x diameter is anchored in the concrete base
Holes	22mm diameter 18mm diameter 26mm diameter 30mm diameter (holes may be punched or drilled)	For M20 bolts For M16 bolts For M24 bolts For M24 bolts Foundation bolts
Welds	Fillet welds made with E35 electrodes	6mm or 8mm leg length 

4 Connection Criteria and Tables

Table 2 Bolt spacing and end distances	
Requirement	Distance
Minimum spacing	$2.5d$ (d = bolt diameter)
Maximum spacing in unstiffened plate: in direction of stress in any environment exposed to corrosion in any direction (lesser of)	$14t$ $16t$ or 200mm (t is the thickness of the thinner part)
Minimum edge and end distance: - rolled, machine flame cut, sawn or planed edge - sheared or hand flame cut edge - any end in the direction that the fastener bears	$1.25D$ $1.4D$ $1.4D$ (D = hole diameter)
Maximum edge distance: normal (greater of)	$12t$ or 150mm (reduce distance when exposed to weather)

The capacity of ordinary bolts to carry the forces should be checked using the formulae in Table 3.

Assume that the bolt threaded portion is present in the shear plane and design accordingly.

The tensile capacity in Table 3 is based on a simple method, where the bolt spacing (cross-centres) is less than 55% of the width of the connecting part. In other cases or where the designer wishes to use a higher strength, then BS 5950 clause 6.3.4.3 should be consulted.

Table 4 lists the strengths in shear, bearing and tension of both 4.6 and 8.8 grade bolts and Table 5 gives the bearing strength of the connection material. The strength of fillet welds is given in Table 6.

The calculated capacities for the bolt diameters and fillet weld sizes in regular use can be found in Tables 7, 8 and 9.

Table 3 Bolt capacity	
Required capacity	Formula
Shear capacity - P_s	$\rho_s A_s$ (ρ_s = shear strength) (A_s = shear area of bolt*)
Bearing capacity of bolt - P_{bb} Bearing capacity of ply - P_{bs}	$t_p \rho_{bb}$ $t_p \rho_{bs}$ (t_p = thickness of the ply) (ρ_{bb} = bearing strength of bolt) (ρ_{bs} = bearing strength of ply)
Tension capacity - P_t	$0.8 \rho_t A_t$ (ρ_t = tension strength of bolt) (A_t = tensile area of bolt*)
Combined shear and tension	$\frac{F_s}{P_s} + \frac{F_t}{P_t} < 1.4$ but no part to be greater than 1.0
See Tables 4 and 5 for Values of ρ_s , ρ_{bb} , ρ_{bs} and ρ_t * If not otherwise known, take shear area A_s and tensile area A_t as being the area at the root of the thread.	

Table 4 Values of bolt strengths ρ_s , ρ_{bb} , ρ_t			
		Bolt grade	
		4.6	8.8
Shear strength	ρ_s	160 N/mm ²	375 N/mm ²
Bearing strength	ρ_{bb}	460 N/mm ²	1000 N/mm ²
Tension strength	ρ_t	240 N/mm ²	560 N/mm ²

Table 5 Values of material bearing strengths ρ_{bs}			
		Steel grade	
		S275	S355
Bearing strength of steel	ρ_{bs}	460 N/mm ²	550 N/mm ²

Table 6 Design strength of fillet welds		
Steel grade	Electrode classification	
	E35	E42
S275	220 N/mm²*	220 N/mm ²
S355	220 N/mm ²	250 N/mm²*

Preferred *

Table 7 Capacities Grade 8.8 ordinary bolts in S275 steel												
Bolt diameter	Tensile stress area	Tensile Capacity at 0.8 x 560N/mm ²	Shear Capacity at 375 N/mm ² Threads in Shear Plane		Bearing capacity at 460N/mm ²							
					Thickness - mm - plate passed through							
	mm ²	kN	Single	Double	6	8	10	12	15	20	25	30
M16	157	70.3	58.9	118	44.2	58.9	73.6	88.3	110	147		
M20	245	110	91.9	184	55.2	73.6	92.0	110	138	184		
M24	353	158	132	265	66.2	88.3	110	132	166	221	276	
M30	561	251	210	421	82.8	110	138	166	207	276	345	414

Table 8 Capacities Grade 8.8 ordinary bolts in S355 steel												
Bolt diameter	Tensile stress area	Tensile Capacity at 0.8 x 560N/mm ²	Shear Capacity at 375 N/mm ² Threads in Shear Plane		Bearing capacity at 550 N/mm ²							
					Thickness - mm - plate passed through							
	mm ²	kN	Single	Double	6	8	10	12	15	20	25	30
M16	157	70.3	58.9	118	52.8	70.4	88.0	106	132	176		
M20	245	110	91.9	184	66.0	88.0	110	132	165	220		
M24	353	158	132	265	79.2	106	132	158	198	264	330	
M30	561	251	210	421	99.0	132	165	198	248	330	383	495

Table 9 Fillet weld capacities			
Weld Strengths for S275 steel E35 and E42 electrodes		Weld Strengths for S355 steel E42 electrodes	
Fillet leg length mm	Capacity at 220N/mm ² kN/mm	Fillet leg length mm	Capacity at 250 N/mm ² kN/mm
5	0.77	5	0.88
6	0.92	6	1.05
8	1.23	8	1.40
10	1.54	10	1.75

5 Typical Connections

Typical connections are described below for multi-storey buildings of simple construction which have bracing or shear walls combined with floor units to provide stability, and also for single storey buildings, including portal frames. Procedures are given for design of the connections.

Most of the connections shown here have limited rotational stiffness. With such connections, it may be necessary to provide temporary bracing, to ensure stability of the frame during its erection.

For more complete information on the design method, worked examples and standardised details, reference should be made to: Joints in Steel Construction - Simple Connections.

5.1 Column Bases

General

Column bases should be of sufficient size, stiffness and strength to transmit safely the forces in the columns to the foundations. Linear pressure distribution may be assumed in the calculation of contact pressures.

Design of base plates (slab base)

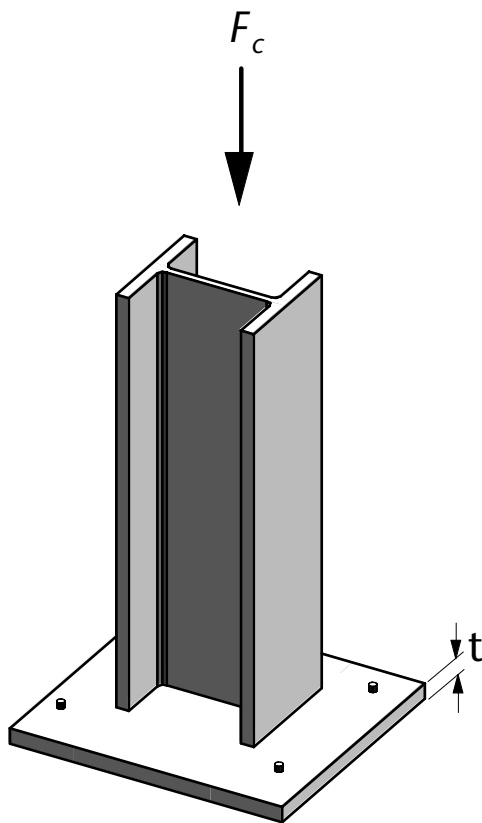

Procedure:

- (i) Choose base plate size, length, breadth, thickness.
- (ii) Choose bearing strength of concrete base/bedding.
(say concrete C25 grade $f_{cu} = 25\text{N/mm}^2$)
Bearing strength = $0.6 f_{cu} = 15\text{N/mm}^2$
- (iii) Required area of base plate is

$$A_{\text{req}} = \frac{F_c}{0.6 f_{cu}}$$
- (iv) Effective area of base plate is

$$A_{\text{eff}} = 4C^2 + (c \times \text{column perimeter}) + \text{area of column}$$
- (v) Equate A_{req} to A_{eff} to find C .
- (vi) Check that ' C ' is within chosen base size.
- (vii) Design welds to accommodate any shear or tension.
- (viii) Make provision for base shear if adequate friction is not available based on coefficient of friction steel/concrete of 0.2.

5.2 Beam-to-column and Beam-to-beam Connections in Simple Construction

Procedures are provided for three types of connection commonly used in simple construction. These are:

- Web Cleats
- Flexible End Plates
- Fin Plates

The use of seating cleats as the only method of carrying the load from beam to column is not usual as beams with such supports usually require stiffeners to prevent web buckling, however, seating cleats may be used as an erection aid.

Beam-to-column web cleats

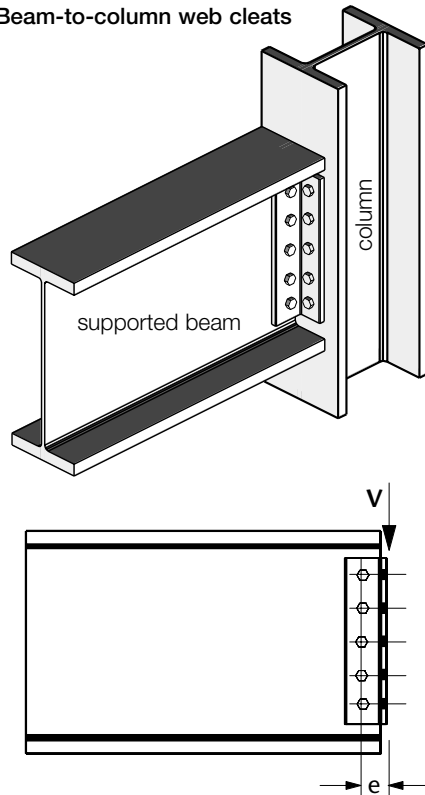

Procedure:

- Choose size of a pair of cleats with length at least 0.6 web depth.
- Calculate the size/number of bolts required in beam web to resist both shear V and moment V_e (See Table 7 or 8 for bolt capacities).
- Check shear and bearing value of cleats (both legs).
- Check shear and bearing of beam web.

Beam-to-beam web cleats

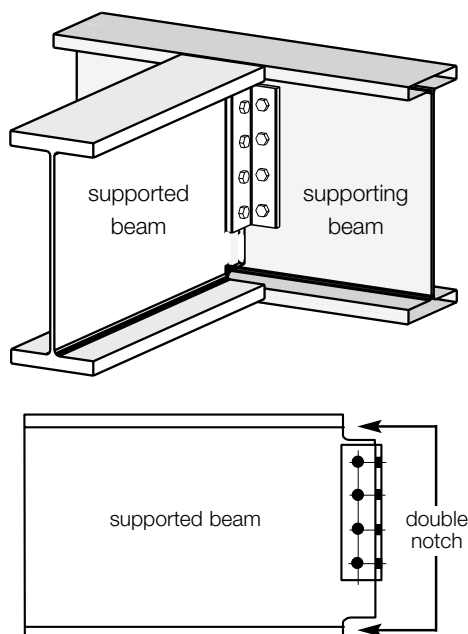

Procedure:

- Choose size of a pair of cleats with length at least 0.6 web depth.
- Calculate the size/number of bolts required in beam web to resist both shear V and moment V_e (See Table 7 or 8 for bolt capacities).
- Check shear and bearing value of cleats (both legs).
- Check shear and bearing of beam web.
- Check local shear and bearing of supporting beam web.
- Check web bending at the junction of a double notched beam.
- Check stability of web in the presence of notches.

Beam-to-column flexible end plate

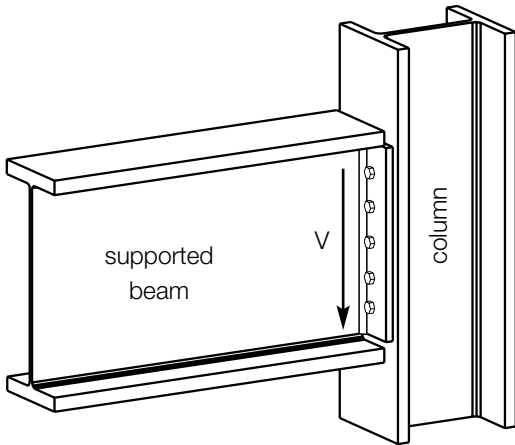

Procedure:

- (i) Choose plate of length ≥ 0.6 web depth.
- (ii) Calculate the size/number of bolts required in plate to resist shear V (See Table 7 or 8 for bolt capacities).
- (iii) Check bearing value of plate and bolts.
- (iv) Check shear and bearing of beam web.
- (v) Check shear capacity of beam web at the connection.
- (vi) Choose fillet weld throat size to suit double length of weld. (See Table 9 for weld capacities).

Beam-to-beam flexible end plates

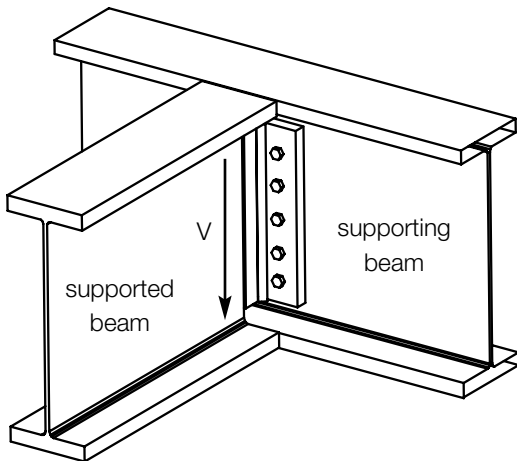

Procedure:

all as Beam-to-column connection above plus:

- (vii) Check local shear and bearing of supporting beam web.
- (viii) Check web bending at the junction of a double notched beam.
- (ix) Check stability of web in the presence of a notch/notches.

Fin Plate

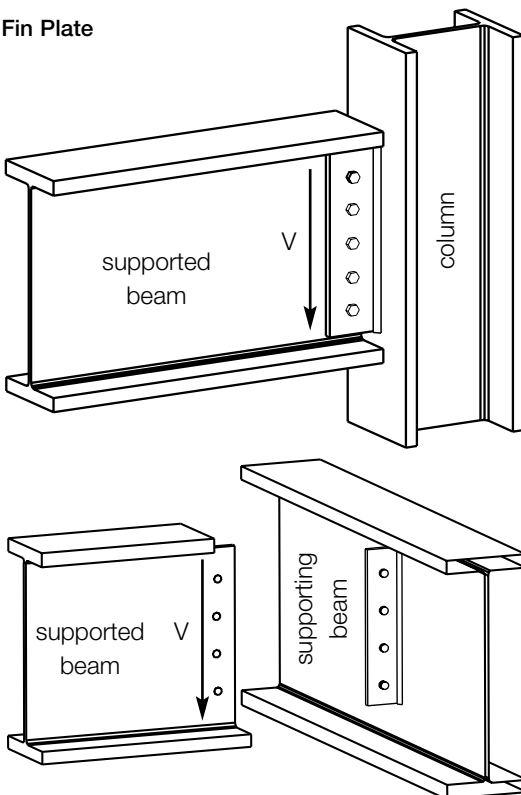

Procedure:

- (i) Choose fin plate size so that thickness is not more than half the bolt diameter and length is at least 0.6 web depth.
- (ii) Calculate the size/number of bolts required to resist both shear V and moment V_e . Use bolts of grades 8.8. (See Table 7 or 8 for bolt capacities).
- (iii) Check shear and bearing value of plate and bolts.
- (iv) Check shear capacity of beam web taking account of plain shear and block shear.
- (v) If beam is notched - check local stability of notch.
- (vi) Make the fillet weld leg length each side of plate $0.8 \times$ plate thickness.
- (vii) Check local shear capacity of supporting beam or column web for beams supported on one or both sides.

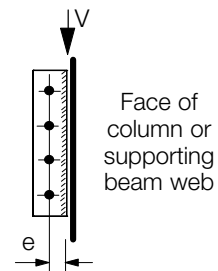

5.3 Column-to-column Splices

Column splices should be located adjacent to the floor and designed to meet the following requirements:

- (a) They shall be designed to hold the connected members in place.
- (b) Wherever practicable the members shall be arranged so that the centroidal axis of any splice material coincides with the centroidal axis of the member. If eccentricity is present, then the resulting forces must be taken into account.
- (c) They should provide continuity of stiffness about both axes, and should resist any tension.
- (d) They shall provide the resistance to tensile forces to comply with the accidental action requirements.

Bearing splices

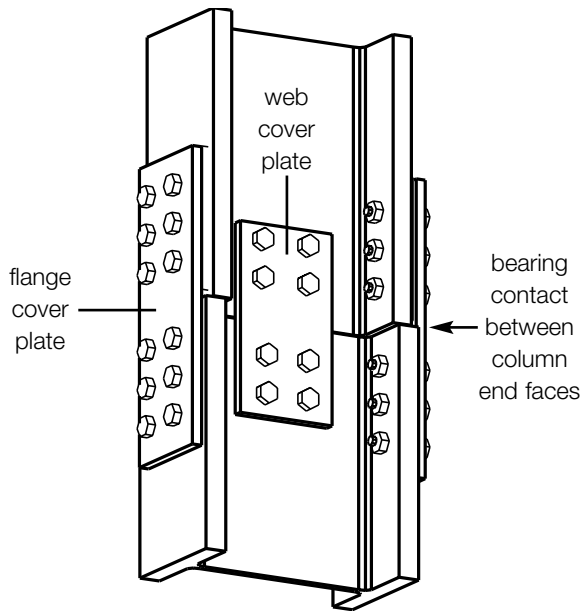

Procedure:

- (i) Flange cover plates should be of a length at least twice the upper column flange width.
- (ii) The thickness of flange cover plates should be the greater of half the thickness of the upper column flange or 10mm.
- (iii) When the upper and lower lengths are the same column serial size, nominal web cover plates may be used.
- (iv) When the upper and lower lengths are different sizes, then web cleats and a division plate should be used to give a load dispersal of 45°.
- (v) Use M24 grade 8.8 bolts for splices in columns of 305 series and above, and use M20 grade for smaller sizes.
- (vi) If the recommended sizes are adopted, no design calculations are necessary, except when moments are present, or in the case of tensile forces described in 5.3 (d) above.

Non-bearing splices

Axial loads are shared between the web and flanges, in proportion to their areas, and bending moments are deemed to be carried by the flanges.

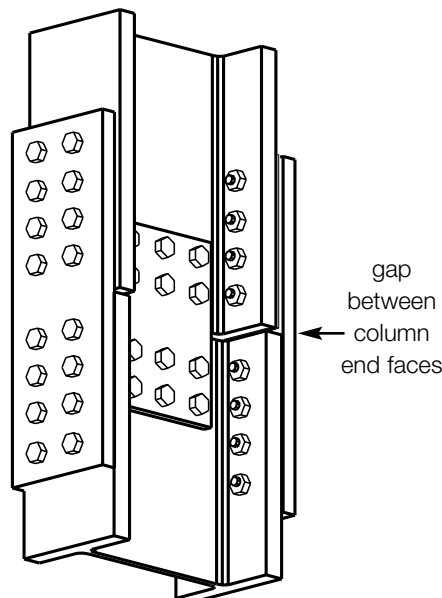

Procedure:

- (i) Choose the splice plate sizes, number and type of bolts. Use pre-loaded (HSFG) bolts in braced bays.
- (ii) Calculate forces in bolts arising from axial loads and moments.
- (iii) Check bolt strengths in single shear.
- (iv) Check the bearing stress in the flanges and splice covers.
- (v) Check the tensile capacity and shear stress in the plate across the net area after deducting the hole areas.

5.4 Portal Frame Bolted Connections

A 'rigorous' and 'hand method' of design of moment connections will be found in "Joints in Steel Construction - Moment Connections". However, an approximate, elastic distribution of bolt force method is given in paragraph (f) below.

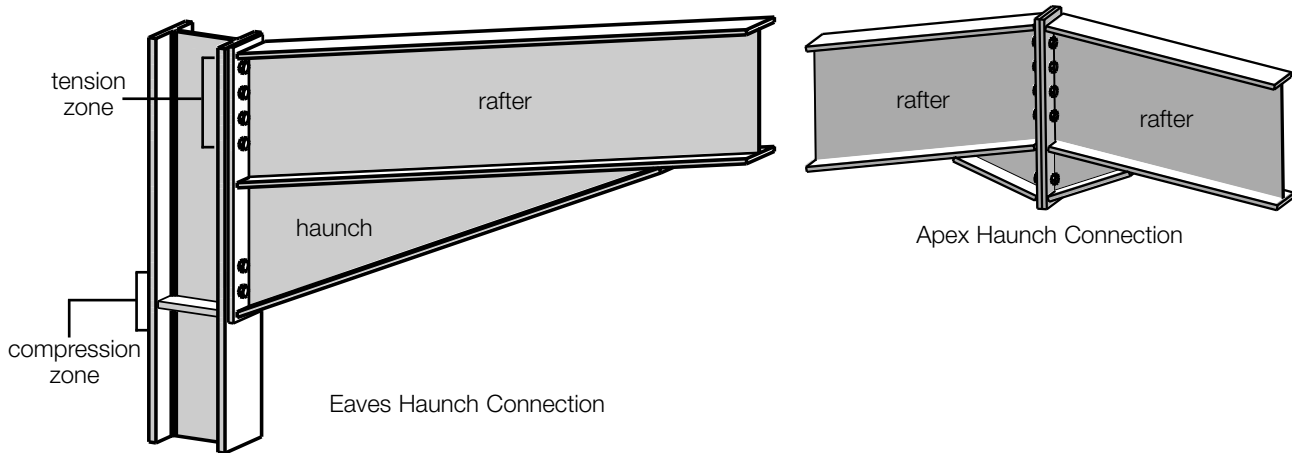

(a) Where frames are designed by the plastic method a plastic hinge may only be allowed to form in the column below the haunch, or in the rafter clear of the haunch.

(b) The depth of haunch chosen may conveniently be arranged so that two haunches may be cut from a single length of the same section as that of the rafter thus:

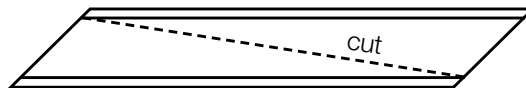

(c) In a portal eaves/valley connection it is recommended that a pair of fitted stiffeners are always provided between the column flanges, in the compression area of the connection, opposite the haunch flange.

(d) Checks should be made on the tension side of the bolted connection to ensure that the column flange can transfer the bolt tension forces to the column web, otherwise flange rib stiffeners are to be provided thus:

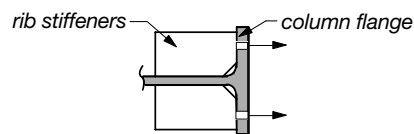

(e) Checks should be made that the column web can develop a shear force equal to the compression force developed by the connection, otherwise web stiffeners are necessary. The web stiffeners can be in the form of Morris stiffeners to provide both web and flange reinforcement thus:

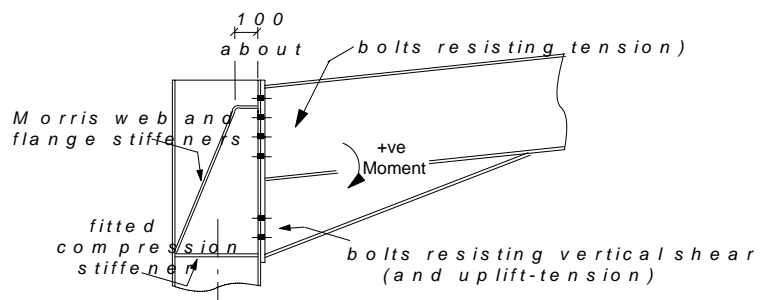

(f) The tensile bolt force distribution may be thus:

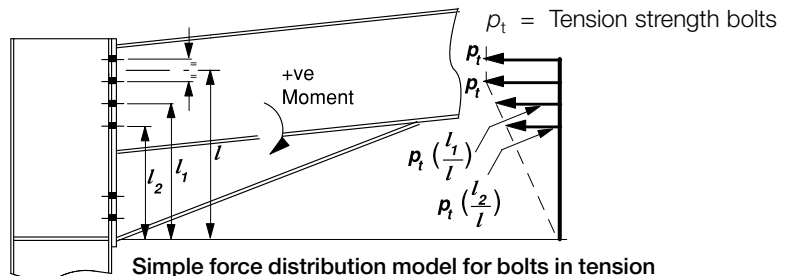

Eaves haunch

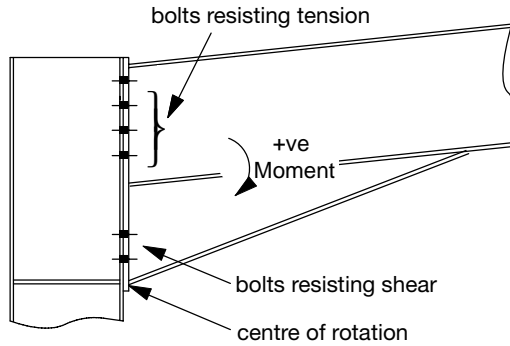

Procedure:

- (i) Assume the number and type of bolts required in tension to resist the factored bending moment, and locate them to obtain the maximum lever arm.
- (ii) Using the force distribution shown in 5.4 (f) calculate the resistance moment. If this is less than the applied moment increase the number and/or size of bolts.
- (iii) Check the thickness of the end plate required to resist the bending moments caused by the bolt tension. Double-curvature bending of the plates may be assumed.
- (iv) Check that the sum of the horizontal bolt forces in tension can be resisted in shear by the column web and provide diagonal web stiffeners or Morris stiffeners if required.
- (v) Check the bending stresses in the column flange caused by the bolt tension and provide stiffeners if found to be necessary.
- (vi) Provide bolts located near the compression zone of the connection to resist the applied vertical shear and ensure that they can act as tension bolts for reversal of moment due to wind.
- (vii) Design welds to resist the force distribution used but also to be commensurate with thicknesses eg:
 - 8mm or 10mm fillets connecting rafter top flange, and haunch flange to end plate.
 - 6mm or 8mm fillets connecting rafter web, and haunch web to end plate.
 - 6mm fillets connecting haunch web to rafter.
 - 6mm or 8mm fillets connecting rib stiffeners or Morris stiffeners.
 - 8mm fillets connecting fitted compression stiffeners to column web and flanges.

Apex haunch

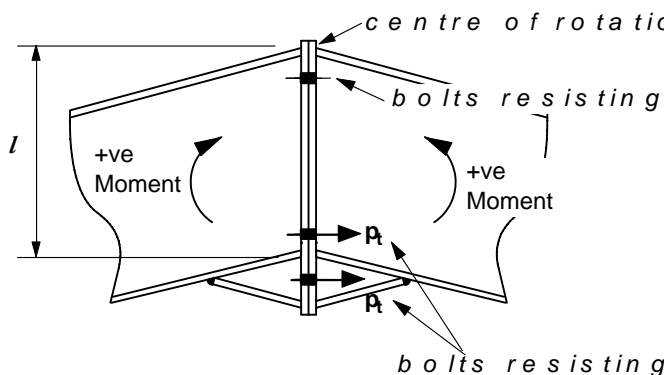

Procedure:

- (i) Assume the number and type of bolts required in tension to resist the factored bending moment.
- (ii) Calculate the resistance moment. If this is less than the applied moment increase the number and/or size of bolts.
- (iii) Check the thickness of the end plate required to resist the bending moments caused by the bolt tension.
- (iv) Check bolts located near the compression zone of the connection to resist the applied vertical shear.

CHAPTER 6

Steel Manufacture

By Alan Todd, Corus Construction & Industrial

1 The Early History

As early as 6000 years ago, early civilizations used iron ore found in meteorites to construct tools. The first iron furnaces appeared in about 1400 BC. These were very simple rounded hearths in which iron ore and charcoal were heated to very high temperatures. By reheating, ironworkers could hammer the metal to remove impurities and increase hardness. It was realised that by making high-quality iron very hot and adding a few other metallic elements an even stronger material could be produced. Small amounts of crude steel were first manufactured in eastern Africa and India as early as 300 BC. The Europeans and Chinese developed steel making processes a few hundred years later.

The industrial revolution had a major impact on steel demand for machinery, railroads, and other ambitious industrial projects. In 1855, Henry Bessemer took out a patent on his process for rendering cast iron malleable by the introduction of air into the fluid metal to remove carbon. The story of the Bessemer steel making process is a classic example of the military impetus for technological development. During the Crimean War, Bessemer invented a new type of artillery shell. The

generals reported that the cast-iron cannons of the time were not strong enough to deal with the forces of the more powerful shell so Bessemer developed his improved iron smelting process that produced large quantities of superior quality steel. Modern steel is still made using technology based on Bessemer's process.

2 Iron Making

Iron is manufactured in a blast furnace. First, iron ore is mixed with coke and heated to form an iron-rich clinker called 'sinter'. Sintering is an important part of the overall process as it reduces waste and provides an efficient raw material for iron making. Coke is produced from carefully selected grades of coal. Different grades of coal are stocked separately and blended before transfer to coke ovens. The coal is heated, or 'carbonised' in the ovens until it becomes coke. It is then removed from the oven, cooled and graded before use in the blast furnace. The coal gas produced during carbonisation is collected and used as a fuel in the manufacturing process while by-products such as tar, benzole and sulfur are extracted for further refining.

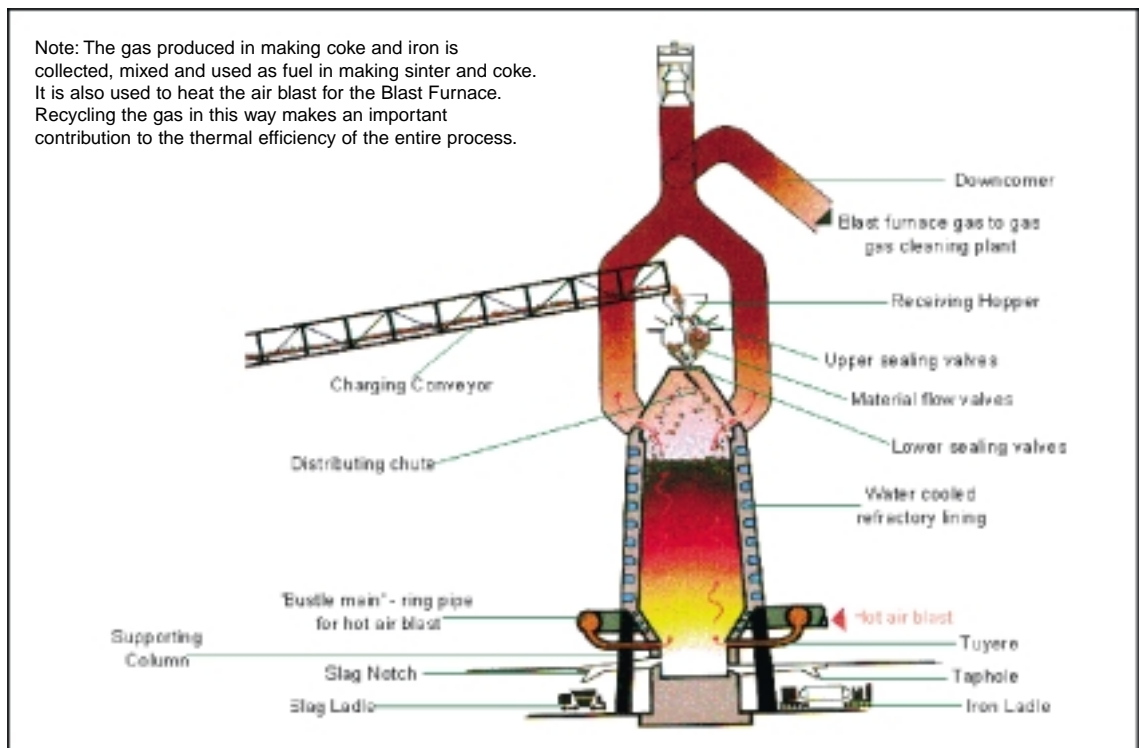

Blast Furnace

Coke, ore and sinter are fed, or 'charged', into the top of the Blast Furnace, together with limestone. A hot air blast, from which the furnace gets its name, is injected through nozzles, called 'tuyeres', in the base of the furnace. The blast air may be oxygen-enriched and coal or oil is sometimes also injected to provide additional heat and reduce coke requirements. The blast fans the heat in the furnace to white-hot intensity, and the iron in the ore and sinter is melted out to form a pool of molten metal in the bottom, or hearth, of the furnace. The limestone combines with impurities and molten rock from the iron ore and sinter, forming a liquid 'slag' which, being lighter than the metal, floats on top of it. The charging system at the top of the furnace also acts as a valve mechanism to prevent the escape of gas, which is taken off through large-bore pipes to a gas cleaning plant.

An important feature of iron making is that the process is continuous. When a sufficient quantity of molten iron accumulates in the hearth of the blast furnace, it is tapped off into ladles for steel making. As slag builds up on the surface of the molten metal it, too, is tapped off at regular intervals through a separate 'notch' or taphole. Meanwhile, the raw materials continue to be charged into the top of the furnace, and heated air blasted in at the bottom. This process goes on throughout the 'life' of the furnace, which can be 10 years or more, before the heat-resistant brick lining begins to deteriorate. The furnace is then relined.

After tapping, the molten iron is 90 to 95 per cent pure and is known simply in the industry as 'hot metal'. This hot metal has some impurities, which will vary according to the quality of the original iron ore and coking coal. The most important of these, from the steel maker's point of view, are carbon, sulfur, phosphorus, manganese and silicon. Iron contains 4 to 4.5 per cent carbon and is therefore brittle and unsuitable for forging or rolling into other products although it is used for castings, where its rigidity and machineability (which both come from its high carbon content) are important. Most iron however is further refined to make steel.

3 Steel Making

The basic raw material for steel manufacture is either the hot metal from the blast furnace, steel scrap or a mixture of both. The proportions of material used vary according to the process and the type of steel required. Steel can be described in general terms as iron with most of the carbon removed, to make it tougher and more ductile. There are many forms of steel, each with its own specific chemical analysis to meet the needs of the many different applications. Two major steel making processes are used today in the UK.

3.1 Basic Oxygen Furnace

Hot metal from the blast furnace and steel scrap are the principal materials used in Basic Oxygen Steel making (BOS). Modern furnaces, or 'converters' will take a charge of up to 350 tonnes and convert it into steel. A water-cooled oxygen lance is lowered into the converter and high-purity oxygen is blown on to the metal at very high pressure. The oxygen combines with carbon and other unwanted elements, eliminating them from the molten charge. These oxidation reactions produce heat, and the temperature of the metal is controlled by the quantity of added scrap. The carbon leaves the converter as a gas, carbon monoxide, which can, after cleaning, be collected for re-use as a fuel. During the 'blow', lime is added as a flux to help carry off the other oxidised impurities as a floating layer of slag. The quantities of scrap, hot metal and lime and other fluxes are calculated to ensure the correct steel temperature and composition. In many plants, refining is assisted by the injection of gases, including argon, nitrogen and carbon dioxide, through the base of the furnace.

After the steel has been refined and samples taken to check temperature and composition, the converter is tilted and the steel is tapped into a ladle. Typically, the carbon content at the end of refining is about 0.04 per cent. During tapping, alloy additions can be made to adjust the final composition of the steel.



BOS furnace charging

3.2 Electric Arc Furnace

The Electric Arc Furnace (EAF) uses only cold scrap metal. The process was originally used solely for making high quality steel as it gave more precise control over the composition. Today, however, it is also employed in making more widely used steels, including alloy and stainless grades as well as some special carbon and low-alloy steels. Modern electric arc furnaces can make up to 150 tonnes of steel in a single melt.

The furnace consists of a circular bath with a movable roof, through which three graphite electrodes can be raised or lowered. At the start of the process, the electrodes are withdrawn and the roof swung clear. The steel scrap is then charged into the furnace from a large steel basket lowered from an overhead travelling crane. When charging is complete, the roof is swung back into position and the electrodes lowered into the furnace. A powerful electric current is passed through the charge, an arc is created, and the heat generated melts the scrap.

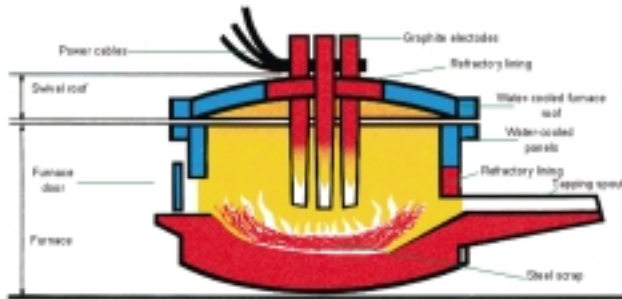

Electric Arc Furnace

Additions of lime and fluorspar are added as fluxes and oxygen is blown into the melt. As a result, impurities in the metal combine to form a liquid slag. Samples of the steel are taken and analysed to check composition and, when the correct composition and temperature have been achieved, the furnace is tapped rapidly into a ladle. Final adjustments to precise customer specification can be made by adding alloys during tapping or, subsequently, in a secondary steel making unit.

3.3 Secondary Steel Making

After the molten metal is tapped into a ladle from the BOS furnace or EAF it is often given one or more extra treatment depending upon the grade of steel required. These further refining stages are collectively known as secondary steel making, and they can include ladle stirring with argon, powder or wire injection, vacuum degassing and ladle arc heating. Some high-grade steels combine all of these treatments. These processes improve homogenisation of temperature and composition, allow careful trimming to precise compositions, remove harmful and unwanted gases such as hydrogen and reduce elements such as sulfur to very low levels.

4 Casting Steel

Before molten steel can be rolled or formed into finished products, it has to solidify and be formed into standard basic shapes called billets, blooms or slabs. Until the development of the continuous casting process, these shapes were always produced by 'teeming' (pouring) the molten steel into ingot moulds. The ingots are placed in soaking pits (ingot re-heating furnaces) to bring them up to a uniform temperature before being passed to the primary mills, which then begin to roll them into the required shapes. However, most modern steels are now continuously cast.

In the continuous casting process the molten metal is poured directly into a casting machine to produce billets, blooms or slabs. Continuous casting eliminates the need for primary and intermediate rolling mills, soaking pits and the storage and use of large numbers of ingot moulds. It also increases the yield of usable product from a given weight of steel and processes the steel into a semi-finished form nearer to that of the finished product.

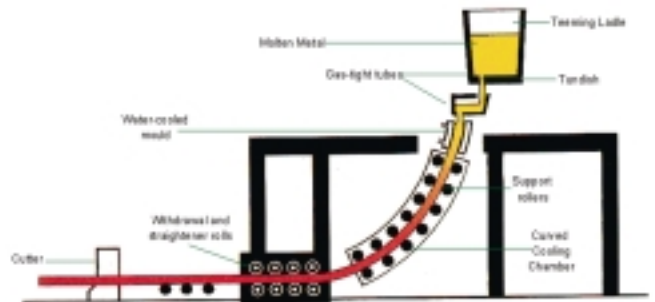

Continuous casting

A ladle of steel is brought to the continuous casting plant by overhead crane. After pre-treatment, which may involve stirring by the injection of an inert gas (argon), the open mouth of the ladle is covered by an insulating lid to reduce heat loss. The whole unit is lifted by crane onto a rotating turret. This makes sequence casting possible – the casting of a number of ladles of the same grade steel without stopping the machine. This is also an important factor in reducing costs.

Before the casting operation, a gas-tight refractory tube is fitted to the outside of the ladle nozzle. This device prevents the liquid steel from taking up excessive oxygen and nitrogen from the atmosphere. The ladle nozzle is then opened, allowing the steel to flow out of the ladle into the tundish, a reservoir supplying the water-cooled copper mould of the casting machine, through another gas-tight tube at a controlled rate.

With only its outer shell solidified, the steel is then drawn downwards from the bottom of the mould through a curved arrangement of support rolls and water sprays until it emerges horizontally as a solid steel slab from the discharge end of the machine, where it is automatically cut to the lengths required.

5 Shaping Steel

Steel is highly resistant to shaping into its finished state but this resistance lessens considerably at higher temperatures. For that reason it is generally worked hot.

The method that is most commonly used for shaping is to roll the steel, squeezing it between sets of cylinders or rolls. To change the shape of a material as strong as steel the rolls must exert forces measured in thousands of tonnes, and must also draw the steel continuously through the rolls while reducing the thickness.

The simplest production unit consists of two horizontal rolls set one above the other in an open housing. Rolling mills have one or more stands, depending on the type of rolling and the products made. Where there are only a few stands these are often arranged in a line, side by side; where there are many stands, as in some rod and bar mills, they are usually arranged in groups set in the direction of rolling.

5.1 Reheating for Rolling

At all hot-finishing mills reheating furnaces are essential to rolling operations and their performance has a big effect on the rate of working the mill. They are normally continuous in operation with several temperature control zones. In pusher furnaces, a continuous line of steel billets, blooms or slabs is pushed through the furnace on skid bars by cold steel pushed in at the charging end. Walking beam furnaces are more flexible, allowing steel to be charged as desired; gaps may be left because each piece is moved individually (it is 'walked' across the furnace floor by moving the transverse members or beams on which it rests) and the heating process is more efficient. Waste gas and heat are recovered to reduce energy costs and computer control used to check temperatures.

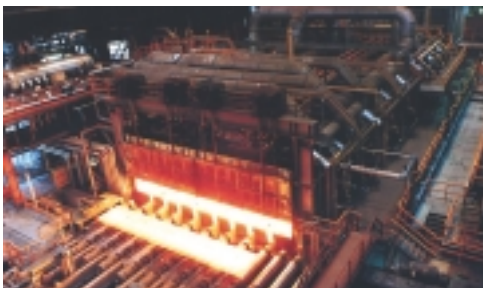

Slab re-heating prior to rolling

5.2 Section Rolling

Sections range from large beams and piling used for construction work down to smaller products including rails, rods and bars. Various types of mill are used. Heavy section and medium section mills have three or four stands with grooved rolls corresponding to the initial roughing, and the

intermediate and finishing stages of rolling. Universal beam mills include stands with both horizontal and vertical rolls bearing on the workpiece. High speed rod and bar mills are used to roll products in small sizes, sometimes square or hexagonal, as well as rounds.



Medium Section Mill



Universal Beam mill stands

5.3 Plate Rolling

Plate is generally rolled in a wide variety of thicknesses and can be up to 4m wide. A roughing stand reduces the continuously cast slab to an intermediate size by a series of reversing end-to-end passes through the mill. This intermediate slab is then rolled to final size in a finishing stand.

5.4 Tube Manufacture

Several different processes are used for making welded tube, all of which follow the basic principle of taking a flat steel plate, and forming it into a cylindrical shape before welding the edges together. The electric welding method forms the bulk of tube production in small and medium sizes, up to 400mm in diameter. Steel strip or plate is uncoiled and guided, cold, through sets of forming rolls to produce the cylindrical shape. At the point where the edges meet, a high frequency current is introduced into the edges of the strip, either by induction using an encircling coil or by contacts sliding on the surface of the strip. The electric current produces enough local heat to melt the strip edges as they are forged together. The weld is formed instantly. Pipe of wall thicknesses above 16mm and with diameters above 400mm are produced by several consecutive forming processes and electrically welded. If square or rectangular hollow sections are required, they are produced by "squaring up" a circular section of the same perimeter and thickness required.



Tube welding

CHAPTER 7

Steel Specification

By Alan Todd, Corus Construction & Industrial

1 Mechanical Properties

Steel derives its mechanical properties from a combination of chemical composition, mechanical working and heat treatment.

The strength of steel can be increased by the addition of alloys such as Carbon, Manganese, Niobium and Vanadium either during tapping or secondary steel making. However, these alloy additions can adversely affect other properties (eg ductility, toughness and weldability). Minimising sulfur levels can enhance ductility, and toughness can be improved by the addition of Nickel. The chemical composition for each steel specification is therefore carefully balanced to ensure the appropriate properties are achieved for the final application of the material.

Mechanical working takes place as the steel is being rolled or formed. The more steel is rolled, the stronger it becomes. This effect is apparent in the material standards, which tend to specify reducing levels of yield strength with increasing material thickness. However, although rolling increases strength, it also reduces the ductility.

The effect of heat treatment is best explained by reference to the various production process routes or rolling regimes that can be used in steel manufacturing, the principal ones being:

- As-rolled steel
- Normalised steel
- Normalised-rolled steel
- Thermomechanically rolled (TMR) steel
- Quenched and tempered (Q&T) steel

Steel cools as it is rolled, with a typical rolling finish temperature of around 750°C. When the steel is then allowed to cool naturally and no further heat treatment is carried out, this is termed 'as-rolled' material.

Normalising takes place when as-rolled material is heated back up to approximately 900°C, and held at that temperature for a specific time, before being allowed to cool naturally. This process refines the grain size and improves the mechanical properties, specifically toughness. It renders the properties more uniform, and removes residual rolling strains.

Normalised-rolled is a process where the temperature is above 900°C after rolling is completed. This has a similar effect on the properties as normalising, but it eliminates the extra process of reheating the material. Normalised and normalised-rolled steels have an "N" designation.

Thermomechanically rolled steel utilises chemistry to permit a lower rolling finish temperature of around 700°C. Greater force is required to roll the steel at these lower temperatures, and the properties are retained unless reheated above 650°C. Thermomechanically rolled steel has an "M" designation.

The process for Quenched and Tempered steel starts with a normalised material at 900°C. It is rapidly cooled or "quenched" to produce steel with high strength and hardness, but low toughness. The toughness is restored by reheating it to 600°C, maintaining the temperature for a specific time, and then allowing it to cool naturally ("Tempering"). Quenched and tempered steels have a "Q" designation.

2 Standards

All steel used for structural purposes in buildings should now be manufactured to a European Standard (EN). These standards are issued in the UK by BSI, with a short National Foreword (that occasionally makes minor modifications to the Standard), and consequently bear the BS EN designation before the reference number. The principal European material standards for building steelwork are:

- BS EN 10025 European structural steel products
- BS EN 10210 Hot finished structural hollow section
- BS EN 10219 Cold formed structural hollow sections

It should be noted that BS EN 10025 was first issued in 1993 but an amended edition was issued in 2003 and this includes standards for products over the whole range of structural steels including fine grain, high strength (TMR, Q&T) and weather-resistant grades previously listed in BS EN 10113, 10137 and 10155. BS EN 10210 and 10219 are being amended to align their general requirements with the amended BS EN 10025.

In the European designation system all structural steels have the prefix "S". This letter is followed by a three digit number that corresponds to the yield strength, eg 275 (in N/mm² or MPa) and by various other letters and numbers that indicate other properties or process routes:

- JR Longitudinal Charpy V-notch impact 27 J @ +20°C ("R" for "Room" Temperature)
- J0 Longitudinal Charpy V-notch impact 27 J @ 0°C
- J2 Longitudinal Charpy V-notch impact 27 J @ -20°C
- K2 Longitudinal Charpy V-notch impact 40 J @ -20°C
- H Hollow Section

- +AR Supply condition as-rolled
- +N Supply condition normalised or normalised-rolled
- C Grade suitable for cold forming
- Z Grade with improved properties perpendicular to the surface (or "through-thickness")

The BS EN standards have replaced British Standards such as BS 4360. Designers may be more familiar with the material grades of the old British Standards, so comparisons are useful, although it should be stressed that the new steels are not simply the old steels with new names – there are some differences in the production processes and properties. A comparison on the steel grades in common use in the UK building design, to the new and old standards is given in the following table.

Comparison of grades to EN10025-2 and nearest equivalent to BS 4360

EN 10025-2: 2003			BS 4360:1990
Grade	Yield (R_{eH})min Strength at t = 16mm (N/mm ²)	Tensile (R_m)	Grade
S275	275	410/560	43A
S275JR			43B
S275J0			43C
S275J2			43D
S355			355
S355JR	50B		
S355J0	50C		
S355J2	50D		
S355K2	50DD		

3 Properties

The properties of steel that are of particular importance to a building designer are:

- Yield strength
- Toughness
- Ductility
- Weldability

3.1 Yield strength

Yield strength is the most common property that the designer will need to use as it is the basis used for most of the rules given in design codes. The achievement of suitable yield strength whilst retaining other key properties has been the driving force behind the development of modern steel making and rolling processes. In the European Standards for structural steels, the primary designation relates to the yield strength, eg S275 steel is a structural steel with a nominal yield

strength of 275 N/mm². The number quoted in the designation is the value of yield strength for material up to 16mm thick. Designers should note that yield strength reduces with increasing plate or section thickness. Section 3 of BS 5950-1: 2000 states that the design strength p_y should be taken as equal to the yield strength but not greater than $U_s/1.2$ where Y_s and U_s are respectively the minimum yield strength R_{eH} and the minimum tensile strength R_m . For the common grades of steel used in UK design practice, design strengths are shown in the following table.

Design strength p_y		
Steel grade	Thickness ¹ less than or equal to mm	Design strength p_y N/mm ²
S 275	16	275
	40	265
	63	255
	80	245
	100	235
	150	225
S 355	16	355
	40	345
	63	335
	80	325
	100	315
	150	295

Note 1 For rolled sections, use the specified thickness of the thickest element of the cross-section

3.2 Toughness

It is in the nature of all materials to contain some imperfections. In steel these imperfections take the form of very small cracks. If the steel is insufficiently tough, the 'crack' can propagate rapidly, without plastic deformation and result in a 'brittle fracture'. The toughness of steel and its ability to resist brittle fracture are dependent on a number of factors that should be considered at the specification stage.

A convenient measure of toughness is the Charpy V-notch impact test. This test measures the impact energy required to break a small notched specimen, at a specified temperature, by a single impact blow from a pendulum. In the material standards, tests are specified typically to achieve a minimum energy value of 27 Joules.

Clause 2.4.4 of BS 5950-1: 2000, describes the requirements to avoid brittle fracture by using a steel with adequate notch toughness, taking account of:

- the minimum service temperature
- the material thickness
- the steel grade
- the type of detail
- the stress level
- the strain level or strain rate

In the UK, the minimum service temperature T_{min} is normally taken to be -5°C for internal steelwork and -15°C for external steelwork. For applications where the steel is exposed to other temperatures, T_{min} should be taken as the minimum temperature expected to occur in the steel within the intended design life of the structure.

The steel specification for each component should be such that its thickness t , satisfies the equation;

$$t \leq Kt_1$$

K is a factor that depends on the type of detail, the general stress level, stress concentration effects and strain conditions as tabulated below.

t_1 is the limiting thickness at the appropriate minimum service temperature T_{min} for a given steel grade and quality, when the factor $K = 1$, as tabulated below for values for steels in common use in the UK.

Factor K

Type of detail or location	Components in tension due to factored load		Components not subject to applied tension
	Stress $\geq 0.3Y_{nom}$	Stress $\leq 0.3Y_{nom}$	
Plain steel	2	3	4
Drilled holes or reamed holes	1.5	2	3
Flame cut edges	1	1.5	2
Punched holes (un-reamed)	1	1.5	2
Welded, generally	1	1.5	2
Welded across ends of cover plates	0.5	0.75	1
Welded connections to unstiffened flanges	0.5	0.75	1

Note 1 Where parts are required to withstand significant plastic deformation at the minimum service temperature (such as crash barriers or crane stops) K should be halved

Note 2 Baseplates attached to columns by nominal welds, for the purposes of location in use and security in transit, should be classified as plain steel

Note 3 Welded attachments not exceeding 150mm in length should not be classified as cover plates

Thickness t_1 for plates, flats, rolled sections and structural hollow sections

Steel Grade and Quality BS EN 10025 BS EN 10210 BS EN 10219	Maximum thickness t_1 (mm) when $K=1$ according to minimum service temperature				
	Normal temperatures		Lower temperatures		
	Internal	External			
	-5°C	-15°C	-25°C	-35°C	-45°C
S 275	25	-	-	-	-
S 275 JR	30	(15) ¹	-	-	-
S 275 J0 (H)²	65	54	30	-	-
S 275 J2 (H)²	94	78	65	54	30
S 355	16	-	-	-	-
S 355 JR	21	(12) ¹	-	-	-
S 355 J0 (H)²	46	38	21	-	-
S 355 J2 (H)²	66	55	46	38	21
S 355 K2	79	66	55	46	38

Note 1 Values in brackets are those previously permitted by BS 5950: 1990 and should be re-instated in the next revision to BS 5950: 2000

Note 2 Hot finished (BS EN 10210) and cold formed (BS EN 10219) hollow sections are commonly available in quality J0 and J2

3.3 Ductility

Ductility is a measure of the degree to which a material can strain or elongate between the onset of yield and eventual fracture under tensile loading. [It should be noted that the term ductility is separately used when toughness is assessed using the Charpy V-notch impact test as this is also referred to as measuring "notch ductility".]

The designer relies on ductility for a number of aspects of design, including redistribution of stress at the ultimate limit state, bolt group design, reduced risk of fatigue crack propagation and in the fabrication process for welding, bending and straightening. Ductility tends to reduce with increasing yield strength but this effect is not significant enough to affect the design of the majority of buildings.

The standards for steel products set requirements for ductility in terms of the elongation of standard-sized test specimens which for structural steels must elongate by typically 20% of their unstrained length. Bearing in mind that the yield strain is typically set at 0.2% proof strain, it may be seen that ultimate strain of the test specimen is some 100 times the yield strain.

Elastic design limits strain to below yield whereas plastic design takes advantage of steel's considerable extra ductility before fracture. However, although steel is noted for its ductility and tolerance of significant distortion, designers should not expect a typical structural member to tolerate 20% strain measured over its whole length before fracture, as the geometry and restraint conditions differ from the standard test specimen. If, as in seismic regions, there is a need to provide ductility in specific regions of the structure, then specific cases may need to be assessed either by physical testing or using finite element modelling.

3.4 Weldability

All structural steels are essentially weldable. However, welding involves locally heating the material, which subsequently cools. The cooling can be quite fast because the material offers a large 'heat sink' and the weld (and the heat introduced) is usually relatively small. This can lead to hardening of the 'heat affected zone' (HAZ) and to reduced toughness; the greater the thickness of material, the greater the reduction of toughness.

The susceptibility to embrittlement also depends on the alloying elements – principally, but not exclusively, on the carbon content. This susceptibility can be expressed as the 'Carbon Equivalent Value' (CEV), and the standard gives an expression for determining this value.

The latest version of BS EN 10025 sets mandatory limits for CEV for all structural steel products covered, and it is a simple task for those controlling welding to ensure that welding procedure specifications used are qualified for the appropriate steel grade and CEV.

3.5 Other Properties of Steel

Clause 3.1.3 of BS 5950-1: 2000 simply states the properties of steel to be used in design:

- Modulus of elasticity, $E = 205,000 \text{ N/mm}^2$
- Shear modulus, $G = E / [2(1+\nu)] \text{ N/mm}^2$
- Poisson's ratio, $\nu = 0.3$
- Coefficient of thermal expansion, $\alpha = 12 \times 10^{-6} / ^\circ\text{C}$ (in the ambient temperature range)

It should be noted that the value for Young's modulus is to some extent a conventional value rather than being exactly equivalent to that obtainable from tests, as the test values do vary for differing grades and conditions. The value specified for design use has been derived from interrogation of test data in the context of the design rules which rely on an assumed value, such as buckling formulae.

3.6 Specification Options

The choice of grade, ie S275 or S355, for a given section or material thickness automatically determines the ductility and weldability of the material to BS EN 10025: 2003. Subgrade selection, eg J2, is specified separately in terms of notch toughness and determines the materials resistance to fracture at low temperatures. The standard offers a number of less common "options", 28 in total are also available to the designer/specifier for consideration. These include specification relating to internal defects, surface condition, transverse testing and types of inspection document.

CHAPTER 8

Plated Beams

By Alan Pottage, Severfield-Reeve Structures Ltd

1 Introduction

Over the past several years there has been a marked increase in the use of long span solutions in commercial office developments. Developers and their professional teams, and indeed building tenants, have all recognised the benefit that column free space offers. Developers can maximise rental income as a consequence of increased lettable area due to column free space; building tenants are less constrained in arriving at their optimum office floor layouts as a consequence of the reduced number of columns.

It has also been recognised that there are advantages to be gained by incorporating the building services through web penetrations within the structural member. This approach has the effect of reducing overall storey heights, and offers the economy of reducing the cost of the building's external envelope which, in the modern signature structures, is a significant proportion of the overall project cost.



Long span plated beam with web penetrations for services

Long span solutions can be achieved by several means, most, if not all of which are designed to act compositely with the concrete floor slab, thereby taking advantage of the compressive strength of the concrete to enhance the supporting steel member's overall capacity to resist the applied forces.

Several composite beam systems are in common use, as listed below:

- "conventional" hot-rolled universal beam and column sections
- lattice trusses
- stub girders
- cellular beams (manufactured from universal beam/column sections)
- plated sections (either plain or cellular or with discrete holes).

This chapter describes the use of plated sections acting as composite beams for long span solutions.

2 Design

A plated beam comprises three constituent plate elements – the top flange, the web and the bottom flange – joined together at the web-flange interfaces by welding.

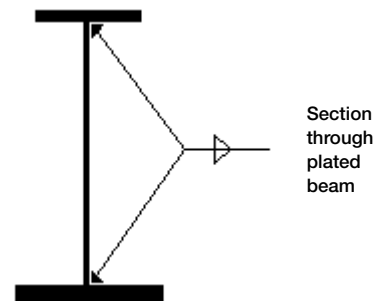

The constituent plate elements are sized on the basis of the beam being designed to satisfy the required Ultimate Limit State (ULS), Serviceability Limit State (SLS) and Fire Limit State (FLS) criteria that are stipulated in both the contract documents and the relevant codes of practice used for design. Depending on the span of the beam and the loading to which it is subject, beam design might be governed by any of the above limit states.

In the ULS, the beam must be able to withstand the bending moments and shear forces that are induced by the applied loads, the latter having been multiplied by specified load factors.

In the SLS, according to BS 5950-1, the beam must be designed to ensure that the deflections induced by the unfactored applied loads "do not impair the strength or efficiency of the structure or its components, nor cause damage to finishes". The code prescribes a further SLS limitation that the natural frequency of the beam (ie its susceptibility to occupant induced vibrations) is such as "to avoid discomfort to users and damage to contents."

For "short" span beams at ambient temperature, with or without web openings, it is generally the ULS that determines the final beam design. The SLS deflection and vibration criteria need to be checked, but these are generally satisfied by default.

For long span beams without web openings, it is generally the SLS that determines the final beam design, with beam strength at ULS then being satisfied by default. However, long span beams with web openings positioned in areas of either high shear or high bending moment may be also be governed by the ULS considerations of strength, depending on the actual hole dimensions and the loading regime.

Although the above observations regarding the governing design criteria at ULS and SLS hold true in what could be deemed the general cases, the plated beam concept offers the designer a significant advantage when confronted with a situation that requires floor depths to be minimised, perhaps in conjunction with the need to transfer a significant point load near to a support.

Within the constraints of the fabrication equipment, plated beams can be "tailor-made" to a specific depth to suit a specific application. The designer is not constrained by the finite depths of rolled sections, for example.

In addition, subject to economic constraints, the transfer of a heavy point load near to a support (eg from several column lifts above a transfer beam) can be achieved by producing a beam with a thicker web in the area of high shear force, and a thinner web elsewhere.

Equally, plated beams need not be of constant depth throughout their length. Several projects have utilised tapered beams of varying section to overcome project-specific problems (see SCI P-068).



Parallel and tapered plated beams with service penetrations

In the FLS, plated beams lend themselves to a rational fire engineering approach by virtue of the fact that the designer has the ability to investigate the use of individual plate elements when arriving at a section that will sustain the FLS forces. This is explained in more detail below.

3 Ultimate Limit State

In the context of composite construction, the design process at ULS must encompass the forces that are induced at both the non-composite construction stage and the final composite stage.

At construction stage, the beam must be able to withstand loads from, for example, the following:

- self weight of the beam
- composite floor deck
- wet concrete
- mesh reinforcement
- construction load allowance.

In general terms, if the ribs of the composite floor deck run perpendicular to the longitudinal axis of the beam, the top flange (which is subject to compression if the beam is simply supported) can be assumed to be fully restrained at construction stage, thereby inhibiting lateral torsional buckling (LTB). This is not the case if the ribs run parallel to the longitudinal axis of the beam due to the deck's lack of stiffness perpendicular to its own longitudinal axis.

Accordingly, the beam must be designed to ensure that LTB at construction stage does not occur. If, at construction stage LTB is governing initial beam design, the use of temporary compression flange restraints should be investigated. The cost of the latter's provision should be compared with that of increasing the size of the constituent plate elements to ensure that the most economic solution is achieved. In many instances, a beam that fails the construction stage design checks may actually satisfy the design checks at composite (ie hardened concrete) stage when subject to the additional loading outlined below.

(It should be noted, however, that when the deck ribs run parallel to the beam, the spanning capability of the completed deck provides permanent restraints at regular intervals along the beam in question, and LTB is not generally a problem.)

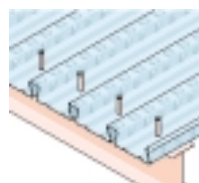

Ward Building Components' re-entrant composite floor deck

In the case of design with pre-cast concrete units, the designer must also be aware of the fact that the laying of the units on one side of the bare steel beam will induce torsional effects that need to be investigated. Again, the provision of temporary beam restraints, to resist the rotation of the beam during placing of the units, should be considered as well as providing clear instructions to the site installation team.

At composite stage, the beam must be able to withstand both the construction stage loads together with the loads that will be applied when the structure is occupied. For example:

- raised floors
- ceilings
- services
- partitions
- imposed loads

In the case of simply supported beams, BS 5950-3-1 permits the moment capacity to be taken as the plastic moment capacity of the composite section, provided that the web is not slender. The use of shear studs ensures that composite action can be utilised.

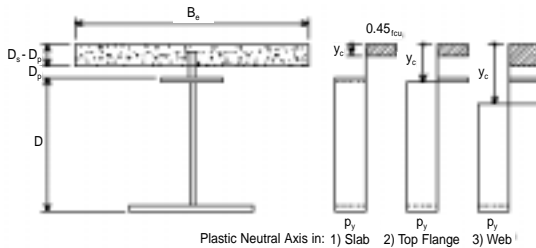

Section through composite plated beam showing plastic stress blocks

The reader is referred to the latest edition of Steel Designers' Manual for a more comprehensive overview of this method of analysis.

4 Provision for Building Services

As illustrated above, the building services can be incorporated within the web of the plated beam, with service penetrations being generally circular, rectangular or "obround" (ie elongated circular).

The structural analysis around the hole is somewhat complicated. Depending on the configuration of the holes, their spacing and the loading regime of the beam, several failure criteria need to be investigated, namely web post shear capacity, web post buckling and Vierendeel bending. In addition, if the centre of the hole is offset vertically from the centreline of the web, an additional check on the web post capacity in bending is required. Equally, if an extremity of a hole is positioned close to the top flange, then local checks on both the

axial and bending capacity of the flange-web "tee" need to be considered.

SCI Publication P-068 gives a comprehensive overview of the treatment of web penetrations.

5 Serviceability Limit State

The SLS, covering both deflection and vibration, must be satisfied and is generally the governing criterion for long span beams (subject to the caveat regarding the disposition of any web penetrations described above).

Deflections of beams of constant section, without web penetrations, can be readily calculated from the standard formulae given in the Steel Designers' Manual and many other structural engineering text books.

In a similar manner, the natural frequency of such beams can be calculated from the standard formula:

$$f = 18/\sqrt{\delta} \quad f = \text{Natural frequency} \quad - \text{Hz}$$

$$\delta = \text{Deflection}^+ \quad - \text{mm}$$

+ the deflection is calculated using elastic composite section properties (utilising a "dynamic" modular ratio) assuming the loading to consist of the dead load and 10% of imposed loading.

The designer should be aware that the calculated value of natural frequency of the beam should only be used as a general indication of the beam's susceptibility to vibration. It is now becoming common practice to consider the response of either complete floors or buildings to induced vibrations, particularly in areas which house sensitive equipment or in which critical processes take place. For more information reference should be made to specialist literature such as SCI Publication P-076.

For beams with web penetrations, and indeed tapered beams, the calculation of deflections and natural frequency is somewhat more complicated.

The calculation of deflections of beams of varying section (ie with a varying second moment of area along their length due to web penetrations/tapered section) is achieved by solving the equation of bending:

$$\frac{d^2y}{dx^2} = - \frac{M(x)}{E.I(x)}$$

Alternatively, a simpler approach can be adopted whereby an additional deflection for each web penetration can be calculated depending on its size and position within the length of the beam (see P-068).

The calculation of the natural frequency of such beams can be achieved by using an energy principle, such as Rayleigh's Method, which equates the maximum potential energy to the maximum kinetic energy of the beam under consideration (see Clough & Penzien).

6 Fire Limit State

In a majority of instances, beams that are incorporated within commercial structures such as multi-rise office developments need to be protected should they be subject to the effects of fire.

In order to ensure that the member can support the loads that are assumed to act at the FLS according to BS 5950-8, it is generally protected by materials that are designed to insulate the beam against a rapid rise in temperature. Protection materials come in the form of boards, sprays and intumescent coatings. Each material is subject to a comprehensive fire testing programme, broadly outlined in the Association for Specialist Fire Protection (ASFP) design guide or "yellow book".

As the temperature of steel increases in a fire, there is a corresponding decrease in its yield strength and Young's Modulus, as shown below. This latter reduction can be quite significant in the design of plated beams in the fire condition, since such sections can exhibit high web depth to thickness ratios, thereby falling into a shear buckling regime.

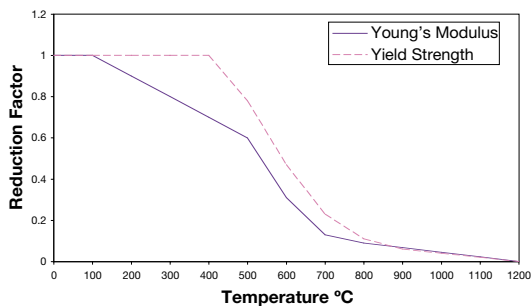

Reduction in yield strength and Young's Modulus with temperature

The heating of each individual element of a plated beam is a function of its heated perimeter to cross-sectional area ratio (H_p/A). As such, in order to inhibit the temperature rise of an element, it is beneficial to provide somewhat "stocky" elements with low H_p/A ratios. [Note: H_p/A has the same value as the ratio A_m/V also referred to in codes, where over a given length A_m is the heated surface area and V is the material volume.]

In simplistic terms, the temperature of the protected bottom flange of a plated beam significantly affects its ability to contribute to the overall bending capacity of the beam in the FLS. In a similar manner, the web temperature governs the ability to withstand shear forces.

Accordingly, the designer should aim for a bottom flange with a low H_p/A ratio, and hence lower temperature and "greater strength" when designing in the FLS, whilst also recognising that too thin a web will result in a reduced shear capacity.

The temperature distribution through a protected beam with web penetrations is significantly different than that through an equivalent plain beam. The ASFP design guide recommends that beams with web penetrations need more fire protection than an equivalent plain beam with no penetrations, and offers guidelines as to the increase in protection thickness that is required.

7 Manufacture

The efficient design and related material economies of plated beams must be accompanied by equally efficient manufacturing techniques.

In the modern fabrication process, the use of Computer Numerically Controlled (CNC) equipment plays a leading role in maintaining the overall economic viability of a plated beam solution. The CNC data that the machine uses to carry out the cutting operation is, in simplistic terms, a series of x/y co-ordinates that defines the path of the cutting head from a pre-defined origin on the plate to be cut. The required CNC data can be input into the machine either manually by the operator or downloaded from a specific file produced from a proprietary draughting software package.

Flange plates can be either standard flats or gas cut from a larger parent plate, thereby enabling several flanges of varying width to be obtained.

Web plates are generally produced by plasma cutting from a parent plate. Any pre-camber that is required can be accommodated by profile cutting the plate at the web-flange interface to a particular radius, enabling the beam to be fabricated to the profile required to allow for significant dead load deflections. Penetrations for services are also cut in this operation. It should be noted that nominally rectangular service penetrations should be detailed with radiussed corners to minimise stress concentrations.



Plasma cutting of web plate and service penetrations

The welding of the constituent plates is carried out by an automated submerged arc process (see chapter 9 and Lincoln Electric Handbook). The arc that is struck between the electrode and the work piece is covered (ie submerged) by a granular flux that crystallises due to the high temperature of the arc. The crystallised flux, which migrates to the top of the weld, serves to both shield the arc and concentrate the heat in the welded joint.

The submerged arc process produces a high quality, deep penetration weld with a throat thickness that is greater than that produced from a conventional fillet weld with the same leg length. BS 5950-1 recognises this by allowing the engineer to design the weld using this enhanced throat thickness, providing a minimum depth of fusion of at least 2 mm can be consistently achieved. With the modern equipment used today, minimum depths of fusion are invariably greater than the 2 mm specified above.

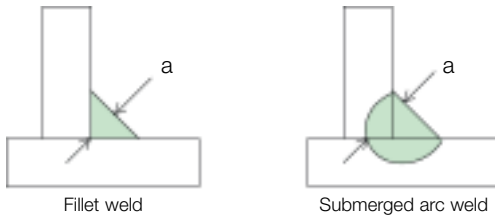

Throat thickness, a , of fillet weld and submerged arc weld

8 Design for Manufacture

The manufacturing process itself should not be viewed as an isolated operation. The fabrication process can be made more complicated by an injudicious selection of plate sizes and web penetrations as early as the structural design stage.

The designer must realise that there is considerable heat input at the flange-web interface during the welding process. Analogous to the H_p/A concept referred to above, a flange with a high H_p/A ratio (ie generally the top flange) will cool at a higher rate than one with a low H_p/A ratio. This differential cooling will induce shrinkage stresses in the beam that may cause the beam to bend. Although the fabrication process may offer some pre-heat prior to welding, efficient fabrication will be compromised should significant controlled cooling be required.

The designer needs to consider what could be termed "balanced" design, and should endeavour to ensure that the centre of gravity of the web-flange welds (which are generally the same size at each web-flange interface) is not excessively offset from the centre of gravity of the final plated section. A large eccentricity, results in an increased possibility of significant post-fabrication distortion.

Indeed, web penetrations should not be detailed too close to the web-flange interface as accelerated cooling and consequent distortion may occur. Equally, the guides to the welding head may pass over the service hole in the web plate should it be positioned too close to the flange, as these guides are supported off the web which is generally placed horizontal in the production process.

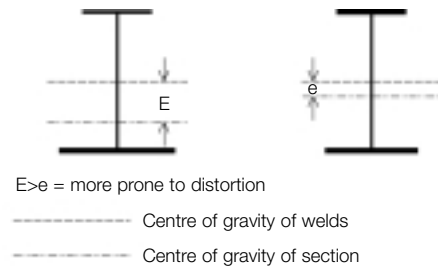

Balanced design

The designer should also recognise that the thickness of fire protection required, particularly if using intumescent coatings in off-site applications, should be such that efficient fabrication is not further compromised. Sections comprising elements with high H_p/A ratios require greater intumescent protection thicknesses, which significantly affect drying time. If the section cannot be handled after a relatively short time period, bottlenecks in the fabrication process will undoubtedly result which impinge on the cost of fabrication. *As is so often seen in structural steel design – minimum weight does not necessarily mean minimum cost.*

CHAPTER 9

Welding

By Richard Thomas, Rowecord Engineering Ltd

1 Introduction

Welding is an important joining process in steel building manufacture. Most endplates and fittings attached in the workshop are welded; in fact it is unusual to make a primary member which does not have some form of welded joint to enable other connecting members to attach. It has therefore become a familiar operation in steel fabrication workshops. Site joints are sometimes welded but the economics of site welding are such that bolted connections are invariably more cost effective.

Welding is a specialist activity and is dependent on many factors. Correct application and control are essential to assure weld integrity and achieve economic production levels. The application of welding to steel building manufacture is subject to a range of British and European standards developed to guide fabricators and engineers to best practice techniques designed to achieve structural serviceability. The aim of this chapter is to give some insight into the processes, the terminology and the applicable standards.

The National Structural Steelwork Specification for Building Construction defines the respective functions and relationships between the standards in regular use. Section 5 states that welding shall be a metal arc process in accordance with BS EN 1011 unless otherwise permitted by the Engineer. The assumption of this standard is that execution of its provisions is entrusted to appropriately qualified, trained and experienced personnel.

2 Principles of Metal Arc Welding

Welding is a complex interaction of physical and chemical science. Correct prescription of metallurgical requirements and sound practical application is a prerequisite for successful fusion welds. It is only possible to summarize some fundamental principles within the scope of this chapter.

The metal arc welding process uses an electric arc to generate heat to melt the parent material in the joint. A separate filler material supplied as a consumable electrode also melts and combines with the parent material to form a molten weld pool. The weld pool is susceptible to atmospheric contamination and therefore needs protecting during the critical liquid to solid freezing phase. Protection is achieved either by using a shielding gas, by covering the pool with an inert slag or a combination of both actions.

Gas shielded processes receive gas from a remote source which is delivered to the welding arc through the gun or torch. The gas surrounds the arc and effectively excludes the atmosphere. Precise control is needed to maintain the gas supply at the appropriate flow rate as too much can produce turbulence and suck in air and can be as detrimental as too little.

Some processes use a flux, which melts in the arc to produce a slag covering which, in turn, envelops the weld pool and protects it during freezing. The slag also solidifies and self releases or is easily removed by light chipping. The action of melting the flux also generates a gas shield to assist with protection.

As welding progresses along the joint, the weld pool solidifies fusing the parent and weld metal together. Several passes or runs may be required to fill the joint or to build up the weld to the design size.

The heat from welding causes metallurgical changes in the parent material immediately adjacent to the fusion boundary or fusion line. This region of change is known as the heat affected zone (HAZ). Common terminology used in the weld area is illustrated below.

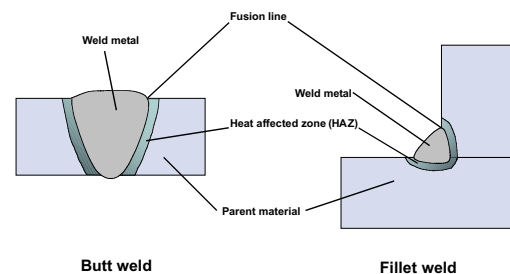

Terminology of the weld area

Welding operations demand proper procedure control delivered by competent welders to ensure that design performance is achieved, to minimize the risk of defective joints caused by poor weld quality and to prevent the formation of crack susceptible microstructures in the HAZ. The main processes in use in steel building manufacture are discussed in further detail below.

3 Types of Joint

Structural welded joints are described as either butt welds or fillet welds. Butt welds for building manufacture are normally in-line joints in sections or plates, either to accommodate a change of thickness or to make up available material to length. The positions of these joints are normally agreed at the design stage to suit material constraints or the erection scheme. Tee butt weld joints are required where there is substantial loading in bearing stiffening or transverse connections.

Butt welds are full or partial penetration joints made between bevelled or chamfered edges or ends of plates or sections. Full penetration joints are designed to transmit the full strength of the section. As noted below, reinforced partial penetration joints can also be sized to be "full strength". It is generally possible to weld these joints from one side but, as material thickness increases, welding from both sides is desirable to balance distortion effects, with an in-process backgouging and/or backgrinding operation to ensure the integrity of the root area. Single-sided butt welds with backing strips, ceramic or permanent steel, are common for joining large plate areas and where there are closed box or tube sections, which can only be accessed for welding from one side. The design throat thickness determines the depth of penetration required for partial penetration welds.

Every effort should be made to design out butt welding as far as possible due to the costs associated with preparation, welding time, higher welder skill levels and more stringent and time consuming testing requirements. In addition, butt welds tend to have larger volumes of deposited weld metal; this increases weld shrinkage effects and results in higher residual stress levels in the joint. Careful sequencing of welding operations is essential to balance shrinkage and to distribute residual stress thus minimizing distortion.

The most common joints in building structures use fillet welds either in a tee or lap configuration. They include end plate, stiffener, bearing and bracing connections to rolled sections and web to flange joints in plated structural members.

In S275 steels full strength is also developed in fillet welds and partial penetration welds with overlying fillets provided that such welds are symmetrical, made with the correct consumables and the sum of the weld throats is equal to the thickness of the element that the welds join.

The project design or detail drawings show the weld sizes. British practice has been to use leg length (z) to define fillet weld size, but this is not universal as throat thickness (a) is now used based on European practice which is becoming the basis of BS EN standards. BS EN 22553 prescribes the rules for the use of symbols to detail welded joints on drawings.

The NSSS requires joint preparations in accordance with BS EN 29692. The standard uses the term recommendations and its provisions should be applied with some flexibility to accommodate sound engineering practice. Cleanliness of the prepared edges and faces is necessary as contaminants such as oil, water, paint and rust adversely influence the welding process causing porosity and other imperfections in the completed joint.

4 Processes

The five main arc welding processes in regular use in UK building manufacturing are described below; variations of these processes have been developed to suit individual fabricator's practices and facilities. Other processes also have a place for specific applications. Process numbers are defined in BS EN ISO 4063.

The important factors for the steelwork fabricator to consider when selecting a welding process are the ability to fulfil the design requirement and, from a productivity point of view, the deposition rate that can be achieved and the duty cycle or efficiency of the process. The efficiency is a ratio of actual welding or arcing time to the overall time a welder or operator is engaged in performing the welding task. The overall time includes setting up equipment, cleaning and checking of the completed weld.

4.1 Metal-active Gas Welding (MAG) – process 135

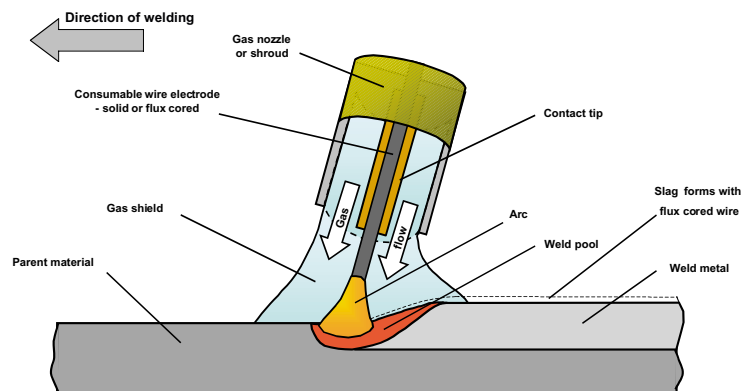

MAG or flux-cored arc welding process

This is the popular choice manually controlled process for shop fabrication work; it is sometimes known as semi-automatic, MIG or CO² welding. The principal features of the process are illustrated above.

Continuous solid wire electrode is passed through a wire feed unit to the gun usually held and manipulated by the operator. Power is supplied from a rectifier/inverter source along interconnecting cables to the wire feed unit and gun cable; electrical connection to the wire is made in a contact tip at the end of the gun. The

arc is protected by a shielding gas, which is supplied from a remote source and directed to the weld area by a shroud or nozzle surrounding the contact tip. Shielding gases are normally a mixture of argon, carbon dioxide and possibly oxygen or helium. Some fabricators use carbon dioxide as the shielding gas particularly for welding thick sections, but the increased spatter levels have persuaded many to switch to multi-purpose mixed gases. The term MIG (metal inert gas) is more correctly applied to joining materials such as aluminium where an inert gas shield is necessary. For steel welding the gas mixtures in common use perform an active role in promoting arc stability and smooth metal transfer to ensure good fusion and bead shape and, in turn, influence the weld metal properties and deposition rates.

The gas shield is susceptible to being blown away by draughts, which can cause porosity and possible detrimental metallurgical changes in the weld metal. The process is therefore better suited to indoor shop manufacture. It is also more efficient in the flat and horizontal positions as welding parameters are sufficiently high to promote the mode of metal transfer known as "spray transfer". Welds in other positions are deposited with lower voltage and amperage parameters needed for the "dip or short circuit transfer" technique and are more prone to fusion defects.

Wire sizes in regular use range from 0.8 to 1.6mm in diameter. Most fabricators select a 1.0 or 1.2mm wire for versatility in building manufacture. For each wire size there are well understood relationships between wire feed speed and current, voltage and arc length. Correct setting of parameters is essential to optimize welding conditions for the application. The introduction of advanced electronic control has enabled equipment manufacturers to develop machines capable of producing a pulsed current or voltage for special applications.

Good deposition rates and duty cycles can be expected with the process, which can also be mechanized with simple motorized carriages where there are long straight runs of fillet weld or multiple pass butt welds. Automated or robotic systems utilize this process in various forms where there is joint repeatability and in particular, for the welding of standard-sized proprietary products.

4.2 Flux-cored Wire Metal-arc Welding with Active Gas Shield (FCAW) – process 136

This process is similar to the MAG process 135, however it should be noted that the direction of travel is frequently a "backhand" or drag technique rather than the "forehand" or push technique illustrated.

The process utilizes the same equipment as MAG welding. However, the consumable wire electrode is in the form of a small diameter tube filled with a flux. The advantage of using these wires is that higher deposition rates can be used particularly when welding "in position", ie vertical or overhead. The presence of thin slag assists in overcoming gravity and enables welds to be deposited in position with relatively high current and voltage thus reducing the possibility of fusion-type defects. Flux additions also influence the weld chemistry and thus enhance the mechanical properties of the joint.

Despite the relative expense of these wires their use is becoming far more widespread because of higher deposition rates and the ability to weld in position. A process variant designed to enhance productivity is to use a metal-cored wire. The electrode consists of a tubular wire with an iron powder core. Significant productivity gains justify the increased cost, however careful procedure control is necessary to sustain the faster travel speeds for high deposition.

4.3 Submerged-arc Welding with Electrode (SAW) – process 121

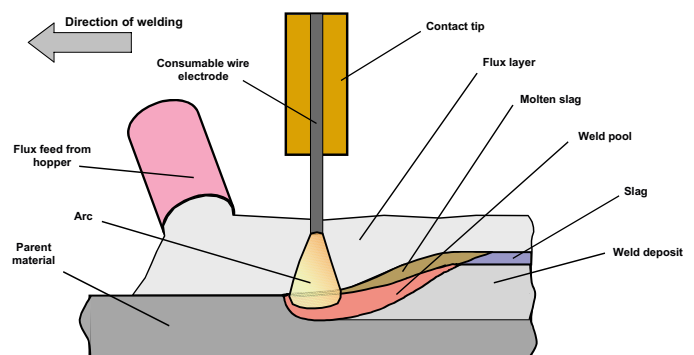

Submerged-arc welding process

Specialist fabricators of large plated structural members, such as box and I-section girders, use this process for welding web to flange fillet welds and in-line butts in thick plate to make up flange and web lengths. Thick-walled tubular sections are also joined economically provided they are straight and are mounted in motorized rollers with accurate control of travel speed. The principal features of the process are illustrated above.

The process feeds a continuous wire into a contact tip where it makes electrical contact with the power from the rectifier. The wire feeds into the weld area, where it arcs and forms a molten pool. The weld pool is submerged by flux fed from a hopper. The flux, immediately covering the molten weld pool, melts forming a slag protecting the weld

during solidification; surplus flux is re-cycled. As the weld cools the slag freezes and peels away leaving high quality, good profile welds.

Solid wires of diameters from 1.6 to 4.0mm are commonly used with agglomerated or fused fluxes. Mechanical properties of the joint and the chemistry of the weld are influenced by careful selection of the wire/flux combination.

The process is inherently safer than other processes as the arc is completely covered during welding, hence the term submerged; this also means that personal protection requirements are limited. High deposition rates are a feature of the process because it is normally mechanized on gantries, tractors or other purpose built equipment. This maintains control of parameters and provides guidance for accurate placement of welds.

The ability to exercise precise procedure control enables fabricators to take advantage of the deep penetration characteristic of the process. The cross-sectional profile of fillet welds deposited is such that to achieve a design throat thickness a smaller leg length weld is required.

Process variants include twin and tandem wire feeds and metal powder additions. These all increase deposition potential but the equipment requirements become more complex. The process is better suited to shop production but site use can be justified where applications include long runs and/or thick plate joints and the area can be weather-proofed.

4.4 Metal-arc Welding with Covered Electrode (MMA or Stick Welding) – process 111

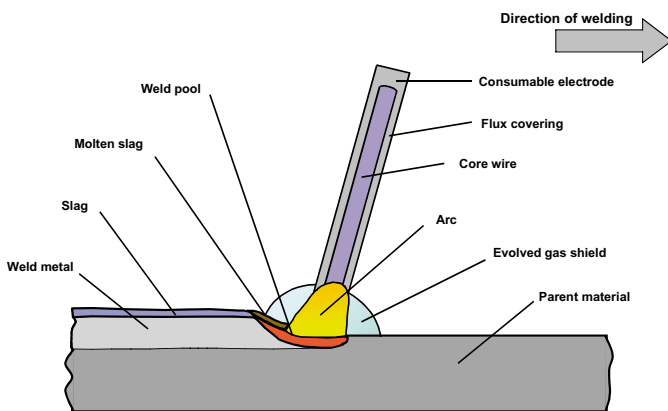

Manual metal arc welding process

This process remains the most versatile of all arc-welding processes however its use in the modern workshop is limited. The principal features of the process are illustrated above.

Alternating current transformers or DC rectifiers supply electrical power along a cable to an electrode holder or tongs. Electrical earthing is

required to complete the circuit. A flux coated wire electrode (or "stick") is inserted in the holder and a welding arc is established at the tip of the electrode when it is struck against the work piece. The electrode melts at the tip into a molten pool, which fuses with the parent material forming the weld. The flux also melts forming a protective slag and generating a gas shield to prevent contamination of the weld pool as it solidifies. Flux additions and the electrode core are used to modify the chemistry and mechanical properties of the weld.

Hydrogen-controlled basic coated electrodes are generally used for higher strength steels. It is essential to store and handle these electrodes in accordance with the consumable manufacturer's recommendations in order to preserve their low hydrogen characteristics. This is achieved either by using drying ovens and heated quivers to store and handle the product, or to purchase electrodes in sealed packages specifically designed to maintain low hydrogen levels. (Section 7 below explains hydrogen cracking.)

The disadvantages of the process are the relatively low deposition rate and the high levels of waste associated with the unusable end stubs of electrodes. Nevertheless it remains the main process for site welding and for difficult access areas where bulky equipment is unsuitable.

4.5 Shear Stud Connector Welding – process 783

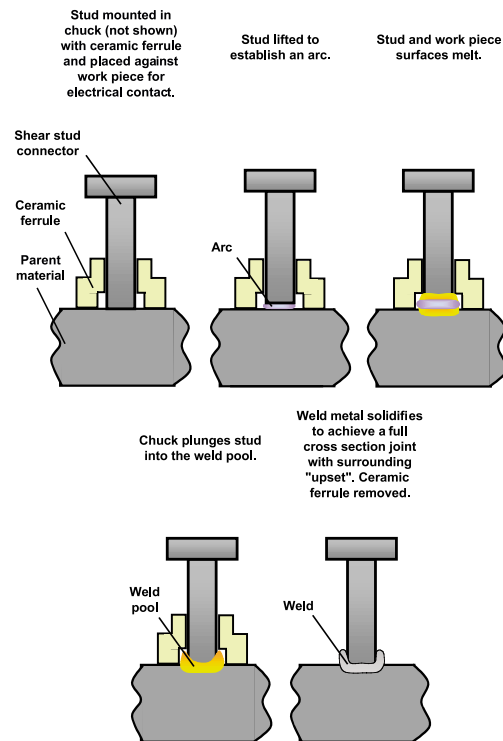

Stud connector welding process

Composite structures require the welding of shear stud connectors to members, either directly to the top flange or through permanent steel deck formwork, where steel to concrete composite action is required. The method of welding is known as the drawn-arc process and differs from the arc welding processes previously described in that there is no additional consumable filler metal, flux or separate gas shield. Specialist equipment is required in the form of a heavy-duty rectifier and a purpose-made gun. The principal features of the process are illustrated above.

Studs are loaded into the gun and on making electrical contact with the work, the tipped end arcs and melts. The arc is timed to establish a molten state between the end of the stud and the parent material. At the appropriate moment the gun plunges the stud into the weld pool. A ceramic ferrule surrounds the stud to retain the molten metal in place and to allow gas generated by the process to escape. The ferrules are chipped off when the weld solidifies. Satisfactory welds have a clean "upset" completely surrounding the stud. The NSSS defines the inspection and testing requirements.

The equipment for stud welding is not particularly portable, so if only a few studs are to be installed or replaced at site, it is more economic to use a manual process.

5 Preparation of Welding Procedure Specifications

The drawings detail the structural form, material selection and indicate welded joint connections. The steelwork fabricator proposes methods for welding each joint configuration to achieve the performance required. Strength, notch toughness, ductility and fatigue are the significant metallurgical and mechanical properties to consider. The type of joint and the welding position together with productivity and resource demands influence the selection of a suitable welding process.

The proposed method is presented on a written welding procedure specification (WPS), which details the information necessary to instruct and guide welders to assure repeatable performance for each joint configuration. An example format for a WPS is shown in BS EN 288-2.

Salient features of the WPS are:

- i) Parent material specification.
- ii) Method of preparing.
- iii) Joint preparation including material thickness, preparation angle, root gap and root face including any tolerances.
- iv) Position of welding.

- v) Consumable type and size including storage and use considerations.
- vi) Shielding gas and/or flux type.
- vii) Electrical parameters, wire feed speed and travel speed or run out length (for MMA) to prescribe the heat input.
- viii) Temperature controls including preheat and interpass temperature and any requirement for post weld heat treatment.
- ix) Welding sequence and method of backgouging where appropriate.
- x) Other information may be required where it is necessary to define the welding technique or additional process controls.

Welding procedure specifications for shop and site welds are provided for the welder and made available for scrutiny by the Engineer and the Inspection Authority prior to commencement of fabrication. It is necessary to support these submissions with evidence of satisfactory procedure trials in the form of a welding procedure approval record (WPAR). The major UK steelwork fabricators have pre-approved welding procedures capable of producing satisfactory welds in most joint configurations likely to be encountered in the steel building industry. It is therefore unnecessary to repeat the prequalification of technically similar procedures for each project.

For circumstances where previous trial data is not relevant it is necessary to conduct a welding procedure test or trial to establish and to confirm suitability of the proposed WPS.

6 Procedure Tests

BS EN 288-3 defines the conditions for the execution of welding procedure tests and the limits of validity within the ranges of approval stated in the specification. The test commences with the preparation of a preliminary welding procedure specification (pWPS). For each joint configuration, either butt or fillet weld, consideration is given to the material thickness and anticipated fit-up tolerances likely to be achieved in practice. Process selection is determined by the method of assembly, the available access and the welding position. Productivity demands and resource needs are also considered.

Joint preparation dimensions are dependent upon the choice of process, any access restrictions and the material thickness. Consumables are selected for material grade compatibility and to achieve the mechanical properties specified, primarily in terms of strength and toughness. For S355 and higher grades of steel, hydrogen-controlled products are used.

The risk of hydrogen cracking, lamellar tearing, solidification cracking or any other potential problem is assessed not only for the purpose of conducting the trial but also for the intended application of the welding procedure on the project. Appropriate measures, such as the introduction of preheat or post heat, are included in the pWPS.

Distortion control is maintained by correct sequencing of welding. Backgouging and/or backgrinding to achieve root weld integrity are introduced as necessary.

Welding voltage, current and speed ranges are noted to provide a guide to the optimum welding conditions.

Once the pWPS is satisfactorily tested using a particular set of conditions, the WPS is approved on the WPAR for use over a range of conditions that are defined as its limits of validity (eg for thinner and thicker material up to defined limits). In selecting the initial set of conditions for the test, the subsequent effect on the ranges of approval for material groups, thickness and type of joint within the specification should be carefully considered to maximize the application of the WPS.

Test plates are prepared of sufficient size to extract the mechanical test specimens including any additional tests specified or necessary to enhance the applicability of the procedure. The plates and the pWPS are presented to the welder; the test is conducted in the presence of the examiner and a record maintained of the welding parameters and any modifications to the procedure needed.

Completed tests are submitted to the examiner for visual examination and non-destructive testing in accordance with Table 1 of BS EN 288-3. Non-destructive testing techniques are normally ultrasonic testing for volumetric examination and magnetic particle inspection for surface examination and crack detection. Radiographic testing is a technique to confirm volumetric integrity, however health & safety issues restrict efficient use of this method to laboratories with specialist equipment and controlled radiation areas.

Satisfactory test plates are then submitted for destructive testing, again in accordance with Table 1. For in-line butt welds, tests specified include transverse tensile, transverse bend and impact tests to determine the mechanical performance of the joint and a macro-examination to confirm the fusion and penetration of the weld. Hardness testing is carried out on the macro specimen. On tee butt joints and fillet welds, it is normally only practicable to conduct macro-examination and hardness testing. Attention is drawn to the Notes qualifying Table 1, as careful scrutiny is needed to ascertain the precise detail of the testing requirements.

A series of further standards details the preparation, machining and testing of all types of destructive test specimen. Normally specialist laboratories arrange for the preparation of test specimens and undertake the actual mechanical testing and reporting.

The completed test results are compiled into a welding procedure approval record endorsed by the examiner. Project specific welding procedures, based upon the ranges of approval, may then be prepared for submission to the Engineer as required and described previously.

7 Avoidance of Hydrogen Cracking

Cracking can lead to brittle failure of the joint with potentially catastrophic results. Hydrogen (or cold) cracking can occur in the region of the parent metal adjacent to the fusion boundary of the weld, known as the heat affected zone (HAZ). Weld metal failure can also be triggered under certain conditions. The mechanisms that cause failure are complex and described in detail in specialist texts.

Recommended methods for avoiding hydrogen cracking are described in Annex C of BS EN 1011-2. These methods determine a level of preheating to modify cooling rates and therefore to reduce the risk of forming crack-susceptible microstructures in the HAZ. Preheating also lessens thermal shock and encourages the evolution of hydrogen from the weld, particularly if maintained as a post heat on completion of the joint.

The calculation of preheat is based upon welding heat input, carbon equivalent value (CEV) derived from the material composition, material thickness, the number of paths of heat dissipation and a determination of the hydrogen level in the consumable product. A worked example in the standard guides the reader through the calculation method.

High restraint and increased carbon equivalent values associated with thicker plates and higher steel grades may demand more stringent procedures. Low heat inputs associated with small welds may also necessitate preheating. Experienced steelwork fabricators can accommodate these requirements and allow for them accordingly.

BS EN 1011 confirms that the most effective assurance of avoiding hydrogen cracking is to reduce the hydrogen input to the weld metal from the welding consumables. Processes with inherently low hydrogen potential are effective as part of the strategy, as well as the adoption of strict storage and handling procedures of hydrogen-controlled electrodes. Consumable supplier's data and recommendations provide guidance to ensure the lowest possible hydrogen levels are achieved for the type of product selected in the procedure.

Further informative Annexes in BS EN 1011-2 describe the influence of welding conditions on HAZ toughness and hardness and give useful advice on avoiding solidification cracking and lamellar tearing.

8 Welder Approval

The NSSS invokes the requirement to approve welders in accordance with BS EN 287-1 although it does permit approval to American standards subject to the agreement of the Engineer. The BS EN standard prescribes tests to approve welders based upon process, type of joint, position and material.

Welders undertaking successful procedure trials leading to approval of a WPS gain automatic approval within the ranges of approval in the WPAR according to the standard.

Welder approvals are time-limited and need re-validating depending on continuity of employment, engagement on work of a relevant technical nature and satisfactory performance. The success of all welding operations relies on the workforce having appropriate training and regular monitoring of competence by inspection and testing.

9 Inspection and Testing

The NSSS requires three main methods of non-destructive testing. Visual inspection of all welds is mandatory and is performed by persons trained and assessed for competence in inspecting the types of welds normally expected on structural steelwork. BS EN 970 provides guidance on inspection requirements and techniques using hand-held gauges for measuring. It is sensible to conduct visual inspection to confirm weld integrity prior to any other non-destructive test.

Surface flaw detection is normally conducted by magnetic particle inspection (MPI) in accordance with the requirements of BS EN 1290. MPI is a method of testing which uses a permanent magnet or electromagnet to establish a magnetic field across the weld. A suspension of fine iron filings is dispensed on to the test area and, if flaws are present, the disruption in the magnetic field causes the filings to migrate and accumulate at the flaw. White background paint is used to enhance the viewing of the test area.

There is provision to use dye penetrant inspection in accordance with BS EN 571 where it is impractical to use MPI equipment or if the material is non-magnetic, eg for joints in stainless steel. Liquid penetrant is applied to the surface under examination. Capillary action draws the liquid into any surface breaking flaws. After a period of soaking the surplus liquid is removed by a cleaning solvent and a developer is applied. Liquid penetrant in any crack or flaw is drawn out and shows in contrast against the developer.

Sub-surface or volumetric examination is carried out by ultrasonic testing (U/S or UT) in accordance with BS EN 1714. The principle of ultrasonic examination involves transmitting a high frequency sound wave through the material using a probe. The wave is received back from a reflector, ie a boundary, such as the far side (or back wall) of the material, or any embedded flaw. The reflected signal is displayed on the screen of the flaw detector. The position of the signal against a time base confirms whether it is the back wall boundary or a flaw. The amplitude and size of the signal depends on the orientation and characteristic of the flaw. Various angle probes are used to transmit sound waves at different angles to define the size and position of any flaws.

MPI and U/S are specialist activities requiring training, experience and examination to assess competence. Various schemes operate to conduct training and examination of persons engaged in these activities. The schemes also monitor competence and issue certification.

Hydrogen cracking, if it occurs, manifests itself during the period after the weld has cooled. The elapsed time is somewhat unpredictable and it is therefore prudent to delay non-destructive testing of joints to minimize the risk of missing serious defects. The NSSS Annex A prescribes holding times normally required after weld completion before testing can take place. The times are based upon the thickness and carbon equivalent value of the material in the joint. Holding times may need increasing in situations where the joint is highly restrained or may be decreased if continuing similar production is satisfactory. The advice of a welding engineer may be needed where circumstances are new or unusual.

The NSSS does not require non-destructive testing, except for visual inspection, if all of the following conditions exist:

- The connection is fillet welded.
- The leg length is not greater than 10mm.
- The member thickness is less than 20mm.
- The material grade is S275 or S355.

The NSSS Annex B Table B defines the scope of inspection and frequency of testing where these conditions are not fulfilled. Various butt and fillet weld joint configurations are described and testing specified depending on thickness. The principle of production quality control on a weekly basis, rather than project-orientated testing, is supported provided that similar joint configurations and materials are repeated in the production cycle. Emphasis can be placed on individual welder performance to ensure consistent application of welding procedures.

The intention is to make inspection and testing activities simpler to apply and monitor. The NSSS requires three months of weekly records showing satisfactory performance applicable to each constructional detail.

Clearly the level of testing can be decreased with continuing satisfactory performance or increased or extended accordingly when problems are encountered. The Engineer may deem it necessary to increase the scope of inspection for critical joints and, if so, this must be communicated to the fabricator in the project specification.

Acceptance requirements and measurement definitions are specified in the NSSS Annex C Tables C.1 and C.2. The Commentary on the NSSS provides further explanations to assist in the interpretation of the tables. In addition Figure 5.1 in the Commentary provides a valuable insight into the common fabrication discontinuities and their causes.

The minimum mandatory scope of inspection and acceptance requirements in the NSSS are related to those established by The Welding Institute (TWI) to achieve a fitness-for-purpose quality level for static structures. The TWI acceptance requirements are set out in BS 5950-2. They should not be difficult for competent welders to achieve in normal circumstances providing joint preparation and assembly is within appropriate fabrication tolerances.

Cyclic stressing at low amplitude does occur in buildings and the permissible size of weld discontinuity has been established to ensure that defects do not grow to failure during the lifetime of the structure. It is emphasised in the text of the NSSS that the acceptance criteria specified in Tables C.1 and C.2 are not intended to apply to bridges, offshore structures or other dynamically loaded structures. In such circumstances, BS 5950-2 recommends reference to ISO 10721-2 which has tables for varying fatigue levels established by TWI on a basis that is consistent with those in BS 5950-2.

CHAPTER 10

Bolting

By Phil Williams, BCSA and Roger Reed, Thomas William Lench Ltd

1 Introduction

Whilst every steelwork designer recognises the significance of connection design, both in terms of a connection's ability to resist applied loads and in terms of its fabrication cost, detailed knowledge of the humble fastener itself is shrouded in some mystery. Even the most enthusiastic designer is forced to admit that the plethora of standards governing the dimensions, materials, coatings, design and application of fasteners is beyond his desire to comprehend.

The development of ISO Standards, of Eurocodes (firstly as ENVs and now as ENs) and of British and European material and product standards, has done little to provide greater clarity to any designer wanting to understand more about the small component that performs such a key role in transferring loads within a structure.

This section outlines some of the historical and current development of relevant standards and gives outline information on the installation of bolt assemblies (or in the new generic terminology "fastener assemblies"). It does not address the issue of corrosion protection of bolt assemblies – this is too extensive a topic to be addressed within the confines of this document.

Within the building frame market, the use of preloaded non-slip joints (with high-strength friction grip bolts or tension control bolts) is not common, but use of HSFG bolts and TCBs does occur where a non-slip connection is required. This section makes brief mention of HSFG bolts, but does not include reference to TCBs due to insufficient space within the section. Full literature on TCBs is available from the manufacturers of these fasteners.

A separate section on *Design of Connections* is also contained within this volume; it provides basic information on 'bolts and bolting' in the form of a table of commonly used bolt strengths and diameters, bolt spacings within a connection group and bolt strengths and capacities. Reference is also made to the BCSA/SCI "Green Book" series covering the design of simple, moment and composite connections. The superseded BCSA publication *Structural fasteners and their application* (the "Brown Book") is currently being updated, and will be published during the first half of 2004.

Although highlighted elsewhere, it is worth repeating that the most frequently used kind of bolts within the

steel structural frame market are 'ordinary bolts', that is non-preloaded bolts of grade 8.8 for main connections and grade 4.6 for secondary connections (purlins and sheeting rails, for example). Recognising the benefits of standardising bolt types and lengths, the sector has moved during the past ten years to the adoption of fully-threaded bolts (technically called screws within Standards); it is estimated that a M20 x 60mm long grade 8.8 fully-threaded bolt is suitable for some 90% of the connections in a typical multi-storey frame.

Whilst the initial parts of this section explain the background to the development of the complex of fasteners standards, they do little to bring greater clarity to any designer who is not a 'bolt expert'. However, it is strongly recommended that reference is made to the section on the installation of fasteners, where practical guidance is given.

2 Standards for Structural Fasteners

2.1 Development of Screw Threads

The development of the first standardised thread system, the British Standard Whitworth system, was in 1841, but did not lead to a single system; instead, two related systems were developed, the US screw and the M-system.

The ISO metric thread derives from the SI (Système International) thread system that was proposed as a result of a conference in Zurich in 1898. This was based on a thread standard already in use in France, but it was found that its small root radius gave very inferior fatigue strength, which led to a number of countries modifying the thread form; this, in turn, resulted in a variety of different SI threads. The International Standards Organisation (ISO) was founded in 1947 and the first technical committee to be created was ISO/TC1 Screw Threads. Initially ISO attempted to produce a single thread standard, but was unable to do so and was forced to accept two standards known as the "ISO Unified Inch" and the "ISO Metric". However, ISO did adopt the thread profile of the Unified system agreed by America, Britain and Canada in 1948, for all ISO (fastener) screw threads. Thus all ISO Metric and ISO Unified thread profiles are identical and their tolerancing systems are derived from similar formulae.

In 1976, agreement was reached, and America and Canada agreed to accept the ISO Metric thread system with some modifications. From this time, ISO standardisation has been on metric threaded fasteners only.

2.2 Non-Preloaded Fasteners for Use in Shear and Bearing Connections

The development of ISO metric fasteners commenced in 1949 with the production of a series of reference standards, mainly dealing with materials, mechanical properties, basic dimensions and dimensional standards. The reference standards were used by national standards organisations to produce the first ISO metric fastener standards. In the United Kingdom, these were the standards BS 3692 and BS 4190.

Within the structural steelwork industry, the most commonly used standard for bolts in shear and bearing connections was BS 4190; generally mild steel bolts of strength grade 4.6. The standard was developed, in part, for use with structural steelwork, and included short threaded bolts that enabled structures to be designed with full shank diameter in the shear plane. With changes in the design of structures, increasing use was made of high tensile strength 8.8 bolts. In an attempt to control costs, the structural steelwork industry developed a hybrid; a short-threaded bolt with coarse (black) dimensional tolerances to BS 4190 and mechanical property class 8.8 to BS 3692.

The use of these hybrid bolts continued unchallenged until the development of the 8.8 fully-threaded bolts during the 1990s, again with dimensions to BS 4190 and mechanical properties to BS 3692. This development came about with the publication of BS 5950, which included design for bolt threads in the shear plane. The number of bolt lengths required for a structure could be significantly reduced, speeding the rate of erection and resulting in lower fastener costs with the economies of scale. Increasingly, property class 4.6 bolts have been replaced with 8.8 bolts, especially where both property classes are included in the design. This is to avoid the risk of the lower grade 4.6 being used where an 8.8 bolt is required.

In 2001, a revised version of BS 4190 was published. This included the more generally used high tensile bolt property classes of 8.8 and 10.9 and their associated nut grades. The revision will meet the general structural fastener requirements until the required CEN/ISO standards are produced. The tables below are extracted, as examples, from BS 4190.

The committee CEN/TC185 was formed in 1989 specifically to address the task of converting the International Standards for fasteners to European Standards. By 1993, conversion of the majority of the most commonly used standards had been completed.

In the mid-1990s, a formal agreement was reached between the International and European Standards Organisations to produce "agreed standards" by dual voting. These are published in the UK as BS EN ISO Standards and will gradually replace the existing BS and BS EN Standards.

The changes in fastener standards from the original British Standards to International Standards are as much about the form in which they are published as the technical content. The practice with British Standards has been to publish a standard that includes all the information relating to a subject or product, whereas with International Standards each deals with one aspect of the product. As a result of this, for example, twelve International or ISO Standards replace the single document BS 3692: Precision Bolts, Screws and Nuts.

Compared with the original British Standards, the technical changes that have occurred with the publication of the BS EN ISO fastener standards cover: across flat sizes; head thickness; measurement of thread length; bolt washer-face diameter; under-head fillet radius and head chamfer. These changes may seem to be minor compared with shank diameter and thread form, but they can have a significant impact – eg whether an internally chamfered washer would be needed to ensure that the under-head fillet radius does not prevent the bolt from seating properly. They can also affect design rules if the common mode of fastener failure were to change from rupture across the thread root to, say, splitting of a narrower or thinner nut.

Dimensions for Black Hexagon Bolts and Screws to BS 419

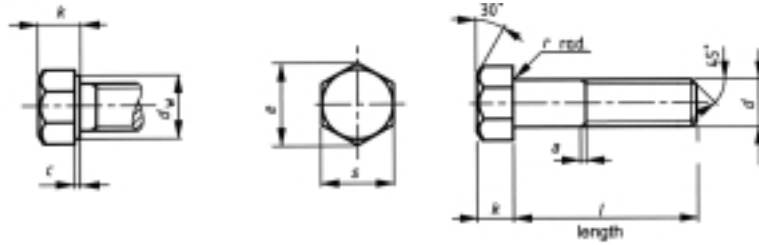

All dimensions in millimetres

Nominal Bolt Diameter	Pitch of Thread p	Diameter of Unthreaded Shank d		Width Across Flats s		Width Across Corners e		Height of Head k		Washer Face Diameter dw	Under Head Radius r	Depth of Washer Face c
		Min.	Max.	Min.	Max.	Min.	Max.	Min.	Max.	Min.	Max.	Max.
M12	1.75	11.30	12.70	18.48	19.00	20.88	21.9	7.55	8.45	17.2	1.25	0.6
M16	2	15.30	16.70	23.16	24.00	26.17	27.7	9.55	10.45	22.0	1.25	0.8
M20	2.5	19.16	20.84	29.16	30.00	32.95	34.6	12.10	13.90	27.7	1.78	0.8
M22	2.5	21.16	22.84	31.00	32.00	35.03	36.9	13.10	14.90	-	1.78	-
M24	3	23.16	24.84	35.00	36.00	39.55	41.6	14.10	15.90	33.2	1.78	0.8
M27	3	26.16	27.84	40.00	41.00	45.20	47.3	16.10	17.90	-	2.28	-
M30	3.5	29.16	30.84	45.00	46.00	50.85	53.1	17.95	20.05	42.7	2.28	0.8
M36	4	35.00	37.00	53.80	55.00	60.79	63.5	21.95	24.05	51.1	2.7	0.8

Dimensions for Hexagon Nut to BS 4190

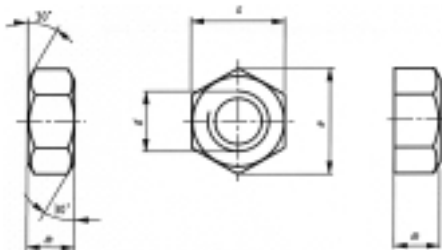

All dimensions in millimetres

Nominal Nut Diameter	Pitch of Thread p	Width Across Flats s		Width Across Corners e		Nut Thickness m	
		Min.	Max.	Min.	Max.	Min.	Max.
M12	1.75	18.48	19.00	20.88	21.90	9.55	10.45
M16	2	23.16	24.00	26.17	27.70	12.45	13.55
M20	2.5	29.16	30.00	32.95	34.60	15.45	16.55
M22	2.5	31.00	32.00	35.03	36.90	17.45	18.55
M24	3	35.00	36.00	39.55	41.60	18.35	19.65
M27	3	40.00	41.00	45.20	47.30	21.35	22.65
M30	3.5	45.00	46.00	50.85	53.10	23.35	24.65
M36	4	53.80	55.00	60.79	63.50	28.35	29.65

2.3 Preloaded Fasteners for Use in Friction Grip Connections

Batho and Bateman first proposed the development of high strength bolts for use in connections in steel structures in 1934. They reported to the Steel Structures Committee of Scientific and Industrial Research of Great Britain that bolts could be tightened sufficiently to prevent slip in structural joints. The work concluded that bolts with a minimum yield strength greater than 25 tonnes per square inch (approx 40 MPa) could be tightened to give enough preload to prevent slippage between the connected parts.

In 1938 at the University of Illinois, Wilson and Thomas reported that the fatigue strength of bolt and nut assemblies, with high preload, was at least as great as well-driven rivets. No further work was done on the concept until 1947 when the Research Council on Riveted and Bolted Structural Joints was formed. The council's work established the suitability of high strength bolts in structural joints: in 1949 the first standard for high strength bolts to ASTM A325 was approved. In 1951 the first standard for structural joints was approved, which permitted the replacement of rivets by bolts on a one-to-one basis.

During the 1950s in the USA, studies were made on installation procedures and the effect of different surface finishes on the slip values of joints. Both in the USA and Germany, studies were undertaken on the use of preloaded bolts in bridges and the behaviour of joints under repeated loadings.

In 1959 the first British Standard for preloaded bolts [BS 3139] was published. This was followed in 1960 by BS 3294, the code of practice for the use of preloaded bolts. The next major development within the UK was the production of the two metric versions of preloaded bolt standards:

BS 4395-1: 1969 General grade bolts, nuts and washers.

BS 4395-2: 1969 Higher grade bolts, nuts and washers.

This was followed in 1970 by BS 4604-1 and -2, which were the relevant codes of practice for the use and assembly of the fasteners in structural steelwork. Of particular importance was the inclusion of the three main methods for tightening of preloaded bolts (see below).

3 Strength of Fasteners

3.1 Mechanical Properties of Fasteners

The mechanical properties of bolts had, until 1999, been prescribed in BS 3692. That standard was superseded by BS EN ISO 898-1: 1999.

Amongst many changes in detail were several important changes in principle; one of these, for example, was the removal of property class 14.9 from the standard, since this is not sufficiently ductile for use in normal structural applications.

There has also been considerable debate across Europe over a number of years concerning the strength of nuts and of over-tapped nuts. It had been demonstrated that nuts could fail by thread-stripping within the nut, a dangerous form of failure since the joint appears to be correctly assembled. The revised European and ISO nut standards have increased nut thickness and hardness, selected such that, in the case of over-tightening, at least 10% of assemblies will fail in bolt breakage rather than nut-thread stripping, giving adequate warning that installation practice is not appropriate.

Further work on over-tapped nuts (to accommodate thick protective coatings) also showed that these would also fail prematurely; this has been overcome by the requirement to select the next higher grade of nut for the assembly (eg a grade 10 nut for an 8.8 bolt).

3.2 Materials for Fasteners

It is important to understand that all fastener specifications provide a wide range of potential materials for bolt manufacturers to work from, with variations in chemical composition, base material and treatment and tempering temperature. It is equally important to understand that different production methods, such as cold forming, hot forging and bar turning dictate the selection of material in the first instance, with a limited selection of materials being appropriate for any one particular production method.

BS EN ISO 898-1 states in the scope of the standard that the fasteners specified are suitable for use in conditions ranging from -50°C to $+300^{\circ}\text{C}$. However, the standard also states that the mechanical properties quoted for the different property classes are for testing at ambient temperature, between 10°C and 35°C .

Increasingly UK structural steelwork contractors are supplying products to countries where sub-zero temperatures and properties are a critical design constraint. The designer and contractor need to be aware of what materials are used to manufacture structural fasteners. Typically, the

materials used by UK fastener manufacturers to cold-form bolts in diameters up to and including M24 will meet low temperature requirements down to -50°C , and -40°C for diameters including M30. Materials for hot-forged fasteners in diameters greater than M30 will require special material selection to achieve good low temperature properties at -50°C , and this would also require special manufacture. Without particular attention to these points, few specifiers would know whether bolts were sourced from cold-formed, hot-forged or machined-bar stock.

The complex range of available materials also delivers significantly different properties at high and low temperatures, as illustrated in the paragraphs below:

High Temperature properties:

- Final material properties are dependent on both steel composition and higher tempering temperatures.
- The properties of carbon and alloy steels and their behaviour at elevated temperatures are summarised in the elevated temperature requirements table of BS EN ISO 898-1.

The effect of increasing temperature is to reduce the mechanical properties, particularly the yield stress. Extended time at elevated temperatures has an even greater effect in reducing pre-load in a bolt and nut assembly.

Property Class	Yield Stress MPa at Temperature $^{\circ}\text{C}$				
	+20 $^{\circ}\text{C}$	+100 $^{\circ}\text{C}$	+200 $^{\circ}\text{C}$	+250 $^{\circ}\text{C}$	+300 $^{\circ}\text{C}$
8.8	640	590	540	510	480
10.9	940	875	790	745	705
12.9	1100	1020	925	875	825

Low Temperature properties:

- The composition (analysis) of the steel used has a major effect on the impact properties and transition temperature obtained with carbon content having the most significant influence on these properties.
- Increasing fastener strength grades results in a reduction in ductility and, hence, impact strength.

BS EN ISO 898-1 does not specify properties at low temperature; the wide range of materials permitted result in too many variations. The transition temperature, the temperature at which failure changes from ductile to brittle, is affected by the chemical composition, particularly carbon content, as shown in the following table:

4 Installation of Fasteners

Transition Temperature $^{\circ}\text{C}$ for Materials of Property Class 8.8

Source Material Specification	BS 3111 Type 9/3	BS 3111 Type 10/2	BS 970 709 M40	BS 970 605 M36	BS 970 503 M36	BS 970 150 M36	BS 970 080 M40	BS 970 070 M55
Range of Carbon Content %	0.17/0.23	0.32/0.39	0.36/0.44	0.32/0.40	0.32/0.40	0.32/0.40	0.36/0.44	0.50/0.60
Transition Temperature	-95°C	-80°C	-74°C	-100°C	-80°C	-62°C	-30°C	$+4^{\circ}\text{C}$

4.1 Matching Combinations

Whilst the tables and the Standards referred to in the earlier paragraphs dealt with individual elements of fasteners – the bolt/screw, the nut and the washer, the table below reproduces an extract from Table 2 of BS 5950-2 – matching bolts, nuts and washers.

This table is extremely important, as it illustrates a way through the plethora of individual standards, to give a tabular summary of what combinations of bolt, nut and washer are appropriate for structural applications. The table is also reproduced in the National Structural Steelwork Specification for Building Construction.

Furthermore, in the extensive notes at the bottom of the main table, guidance and requirements for increasing the class or grade of the nut where the assembly has been specified with a protective coating is given.

As far as the designer or specifier is concerned, all the necessary knowledge and background information necessary is summarised in this table, as are the appropriate BS and BS EN ISO Standards.

4.2 Non-Preloaded Fasteners in Shear Connections with Clearance Holes

This is the typical situation for the majority of connections in ‘normal’ building frame structures, and is usually referred to as a ‘simple connection’, where the main fastener loads are in bearing and shear. The ratio of shear stress to tensile stress is approximately 62%; this value was determined experimentally with ASTM A325 and A490 bolts in the USA in 1965.

The fasteners are required to bring the structural members into contact with each other and maintain stability of the structure. Tightening of the bolt assembly is also required to ensure that loosening of the joint does not occur; this requires the maintenance of a level of tension in the joint or the provision of some preventative measure (see below). Where the fastener is relied upon to resist ‘tension’ alone, non-preloaded fasteners are not suitable for use in situations where fatigue or stress reversal occur.

Additionally, the axial tensile stress should not be high enough to result in a reduction of the shear capacity of the bolt. Some work carried out in the USA indicates that the axial tensile stress needs to exceed 20-30% before a reduction occurs in the bolt shear capacity, and thus this level of tension is satisfactory when achieving a "snug tight" condition for an assembly used in a shear/bearing mode. For these fasteners, it is generally accepted that tightening with a "podger" spanner will develop the level of tension required;

alternatively, a percussion wrench can be used up until the point it begins its 'hammering'.

In the tightened condition there should be at least one full thread and the point visible protruding beyond the nut face; in addition, the dimensions selected should ensure a minimum of one thread and the thread run-out between the loaded nut face and the full shank diameter (although it is obviously impossible to visibly check this once the assembly is tightened).

Matching Bolts, Nuts and Washers

Type of Bolts		Nuts		Washers	
Grade	Standard	Class or Grade c	Standard	Class	Standard
<i>Non pre-loaded bolts</i>					
4.6	BS EN ISO 4016 BS EN ISO 4018	Class 4 ^d	BS EN ISO 4034	100 HV	BS EN ISO 7091
	BS 4190 BS 4933 ^a	Grade 4	BS 4190	—	BS 4320 ⁱ
8.8	BS EN ISO 4014 ^b BS EN ISO 4017 ^b	Class 8 ^e	BS EN ISO 4032 ^b	100 HV	BS EN ISO 7091
	BS 4190	Grade 8 ^f	BS 4190	—	BS 4320 ⁱ
10.9	BS EN ISO 4014 ^b BS EN ISO 4017 ^b	Class 10 ^g	BS EN ISO 4032 ^b	100 HV	BS EN ISO 7091
	BS 4190	Grade 10 ^h	BS 4190	—	BS 4320 ⁱ
<i>Non pre-loaded HSFG bolts</i>					
General grade	BS 4395-1	General grade	BS 4395-1	—	BS 4320 ⁱ
Higher grade	BS 4395-2	Higher grade	BS 4395-2	—	BS 4320 ⁱ
<i>Preloaded HSFG bolts</i>					
General grade	BS 4395-1	General grade	BS 4395-1	—	BS 4395-1 ^k
Higher grade	BS 4395-2	Higher grade	BS 4395-2	—	BS 4395-2 ^k
<i>Holding down bolts</i>					
4.6	BS 7419	Grade 4	BS 4190	—	BS 4320 ⁱ
8.8	BS 7419	Grade 8 ^f	BS 4190	—	BS 4320 ⁱ
8.8 preloaded	BS 7419	General grade	BS 4395-1	—	BS 4395-1 ^k

^a BS 4933 has been declared obsolescent, but should still be used for 90° countersunk head bolts and cup head bolts until corresponding BS EN standards are available.

^b Grade 8.8 and 10.9 bolts to the strength grades of BS EN ISO 4014 or BS EN ISO 4017 but with the dimensions and tolerances specified in BS EN ISO 4016 or BS EN ISO 4018 may also be used, with matching nuts to the strength classes of BS EN ISO 4032 but the dimensions and tolerances of BS EN ISO 4034.

^c Nuts of a higher class or grade may also be used.

^d Class 5 nuts for size M 16 and smaller.

^e Nuts for galvanized or sherardized 8.8 bolts shall be class 10.

^f Nuts for galvanized or sherardized 8.8 bolts shall be grade 10 to BS 4190.

^g Nuts for galvanized or sherardized 10.9 bolts shall be class 12 to BS EN ISO 4033.

^h Nuts for galvanized or sherardized 10.9 bolts shall be grade 12 to BS 4190.

ⁱ Black steel washers to section 2 of BS 4320, normal diameter series.

^j Black steel washers to BS 4320:1968, Section 2, large diameter series.

^k Direct tension indicators to BS 7644 may also be used with preloaded HSFG bolts.

4.3 Fasteners in Preloaded Connections

In this form of connection, fastener loads are principally axial tension; the bolts should not be subject to shear and bearing stresses. The fasteners act to bring the structural members into close contact with each other; the high axial loads generate friction between the so-called "faying" or contact surfaces of the structural members, which enables shear loads to be carried through assembled connection, without slip. This results in a rigid structure that is resistant to both movement and fatigue. Use of slotted or over-sized holes may also be permitted in such connections which then allows for adjustment of dimensional fit-up to be made using such connections.

In UK practice, tightening is required to generate a final axial prestress load of at least 70% of the minimum tensile load of the bolt. However, there are initially two components of 'load' experienced by the fastener – the axial tension generated and the torsion from the wrench as the bolt assembly is tightened against the internal friction between the parts of the fastener assembly. Thus, the assembly is under its maximum load during and immediately before completion of the tightening process.

From that initial 'tightened' position, the bolt assembly undergoes some relaxation and, therefore, a loss of pretension force, which arises from:

- Elastic recovery with the removal of the tightening wrench. This ranges between 2 and 11% with a typical average value of 5%.
- A further 4 to 6% relaxation found to occur in the period from immediately after tightening to in excess of 20 days – factors contributing to this include:
 - Grip length – relaxation increases as the grip length is reduced.
 - Number of plies – increasing the number of plies for a constant grip increases relaxation.
 - Galvanized assemblies are found to have twice the level of relaxation as a self-colour assembly – thought to be due to the creep or flow of the zinc coating.

When tightened, at least one full thread and the point should be visible beyond the nut face, and dimensions should be selected to ensure a minimum of four threads and the thread run-out between the loaded nut face and the full shank diameter.

For obvious reasons, it is very important that the assembly should be correctly and fully tightened, delivering the expected amount of prestress action. This requirement demands special care

where certain bolt protective coatings are in place, as these can adversely affect the tightening process. So, for example, if the bolt and nut have zinc coatings (especially when both the threads are coated) failure to lubricate them can result in pick-up (galling) and ultimately failure by torsional shear during tightening. Lubrication may be achieved using the traditional tallow or beeswax, although any good high-pressure lubricant is satisfactory, including Molybdenum Disulfide.

5 Installation Methods for Preloaded Bolts

There are three primary methods of tightening preloaded bolts, namely:

- Torque control
- Part-turn method
- Direct tension indicator

5.1 Torque Control

This method is explained in BS 4604, but it should be remembered that the calibration required on the equipment and on the bolts is specific to each batch of bolts and nuts – a new batch should immediately require a re-calibration of the equipment and bolt assemblies.

The use of torque values from 'standard' tables is dangerous since actual conditions will vary widely between each batch of bolts and nuts, and site conditions will have a marked effect on the tightening process and torque required. Using such standard data can only be assumed to be giving reliable data when torque tension fluid is applied to both bolt and nut threads. Standard tabulated values are normally calculated on the basis of self-colour (ie untreated) bolts and nuts. The addition of any coating, zinc or otherwise, will significantly alter these values.

5.2 Part-turn Method

This method depends on the application of a 'bedding torque' – defined as that needed to bring the surfaces into good contact (and values for this torque are sometimes stipulated). At this point the relative position of the end of the bolt and the nut is identified by permanently marking (with a centre-punch mark on each), and the nut is then further rotated by a specified amount (usually half a turn, ie 180°).

The initial tightening, usually achieved with a podger spanner or a power wrench, is the greatest area of 'inaccuracy' in this method; the fixed extension of the bolt achieved by the half-turn rotation is relatively accurate. Some specifications overcome this by specifying an initial bedding torque to be applied by a calibrated wrench, but

this may or may not be sufficient to bring surfaces into adequate initial contact. Apart from this initial potential inaccuracy, this method does achieve good results, but not to the same level of certainty provided by direct tension indicators.

Zinc coated fasteners do cause difficulty, and lubrication needs to be carefully considered – both the lack of and excessive lubrication could result in bolt failure (this risk applies, of course, to other methods except the direct tension indicator method of tightening).

In the UK this method is limited to BS 4395-1 (Grade 8.8) bolts. In the USA and in European Standards both 8.8 and 10.9 grades can be tightened by this method.

5.3 Direct Tension Indicator (originally referred to as Load Indicating Washer)

BS 7644 gives the specification and assembly methods for Direct Tension Indicators – this method of achieving the required minimum shank tension is now the usual practice in the UK. The only reference to ‘torque tables’ necessary is to establish the size and capacity of the power/pneumatic wrench required to guarantee that the tension can be achieved in one tightening. The tightening method does not rely on torque, but on the measurement of shank tension through the ‘squashing’ of the indicator washers to leave a specified gap (usually 0.40mm). Lubrication is still important, as poor lubrication can result in bolt failure by torsional shear.

6 Specification and Other Issues

6.1 Specification

Section 6 of the NSSS is entitled *Workmanship – Bolting*, and in the form of standard specification clauses outlines requirements to cover all the issues highlighted above. It relies on Table 2 of BS 5950-2, splitting the single compound table of the standards into Tables 2.2 to 2.6 within the NSSS.

It is pertinent to quote just a few clauses from the NSSS4, as follows:

Clause 6.1.3: Differing Bolt Grades

Different bolt grades of the same diameter shall not be used in the same structure, except when agreed otherwise by the Engineer.

Clause 6.1.8: Bolt Tightening

Bolts may be assembled using power tools or shall be fully tightened by hand using appropriate spanners in accordance with BS 2583.

Clause 6.2.1: Fit-Up – Non-Preloaded Bolt Assemblies

Connected parts shall be firmly drawn together.

If there is a remaining gap which may affect the integrity of the joint, it shall be taken apart and a pack inserted.

Clause 6.4.1: Fit-Up – Pre-Loaded Bolt Assemblies

Connected parts intended to transfer force in friction shall be firmly drawn together with all bolts partially tightened. The joint shall then be examined and if there is any remaining gap which may affect the integrity of the joint, it shall be taken apart and a pack inserted before recommencing the tightening process.

6.2 Ductility

Reference has already been made to the importance of having adequate bolt ductility – this can only be achieved for bolt grades 4.8, 8.8 and 10.9. For structural steelwork, use of grades 12.9 and 14.9 should be avoided due to lack of ductility and the consequent increased likelihood of fracture. Indeed, BS 5950-2 makes no allowance for the use of grades 12.9 and 14.9.

Equally important is the issue of bolt length – both the number of threads protruding beyond the end of the nut **and** the number of threads in the ‘stressed length’ (ie between the thread run-out and the nut face). Ductility of the bolt is improved greatly by having sufficient threaded length in the stressed portion of the bolt; this is not a problem with fully-threaded bolts, which are ideally suited to connections where maximum ductility is a requirement.

This issue is covered in Advisory Desk item AD 268, in the November/December 2003 issue of *New Steel Construction*.

6.3 Vibration

Joints required to have non-slip characteristics under cyclical or fatigue loading have to employ pre-loaded friction grip bolts. However, many other kinds of ‘ordinary’ connection are subject to vibration from machinery etc that might cause the assembly to become loose. In considering whether it is appropriate to use pre-loaded HSFG bolt assemblies to obviate this problem, it is generally not economic to do so as a much simpler solution will suffice.

Clearly, the bolt assembly must remain intact without the nut coming loose due to the vibration to which it is subjected. This can easily be achieved by considering the use of a ‘locking system’, to prevent the nut from loosening – this can be in the form of a second nut, a thinner ‘lock-nut’, or a ‘pal-nut’. Other possibilities are spring washers, proprietary ‘nylocs’ (nuts with an integral nylon washer that grips the bolt thread). In some applications a measure of pre-load sufficient only to overcome the tendency to loosen might suffice.

CHAPTER 11

Fabrication

By Roger Pope, BCSA Technical Consultant

1 Introduction

Fabrication of structural steelwork consists of cutting pieces of steel to shape and connecting them together to form a framework. The cutting processes used include sawing and burning; the connecting processes are generally either welding or bolting.

Traditionally the cutting processes have been guided by templates that provided a model for the shape required. Nowadays most cutting is computer controlled using "virtual templates" provided by a fabrication detailing application.

Shop assembly is mostly by welding, whereas site assembly is mostly by bolting. Assembly (or "plating") and welding relies heavily on the skills of the fabricator as it is rarely automated. The large size of many structural steel components has militated against the widespread use of robots for welding, although automatic control of welding is used for manufacture of large plate girders.



This chapter draws on the wider advice given in the Design for Manufacture Guidelines (see chapter references).

2 Costs

There are three main factors that contribute to the cost of fabrication:

- Materials used
- Processing and handling
- Assembling and welding
- Type of structure

Production of economic fabrications requires designers and detailers to pay attention to the balance between these cost factors, as follows.

2.1 Materials Used

Rarely will a minimum weight design produce the most economic fabrication. The trade-off between workmanship and material is approximately one man hour in the shop to 16 kg of steel. Thus if steel sizes are minimised and this results in an increased need for stiffeners in the connection zones, the cost will increase as even small stiffeners can take more than an hour to prepare, fit and weld.

The steel specified on a given structure should be rationalised in terms of using relatively few section sizes and a common grade. This leads to economies and programme benefits in terms of purchasing, handling and general repetition.

With care, it is often possible to gain benefit from using grade S355 steel products as these are up to 30% stronger than the S275 grade whilst often costing less than 10% more. The exceptions are where deflection governs selection, or where the choice would lead to only small quantities of S355 material being needed as these can be difficult to resource.

If consideration is being given to specifying "special" grades (eg S460) then it is always wise to check with a steelwork contractor about the availability and any potential fabrication cost premium.

Generally the designer specifies the materials to be used for the structural members, leaving the steelwork contractor's detailer to undertake the connection design. The choice of materials to be used in the connections should be left to the detailer wherever possible.

2.2 Processing and Handling

The benefits of fabrication automation have been most marked in terms of processing and handling materials during preparation. Sawing, drilling, punching, are surface blasting are generally all numerically-controlled processes with extensive mechanical conveyors used to move material from one work station to the next.



Efficient and economic processing occurs when the materials do not require handling by overhead cranes or other non-automatic methods. After processing batches of prepared materials are delivered to the location where the assembly and welding processes take place.

Ideally connections should be selected to avoid mixing welding and drilling on any one member as this reduces the amount of handling needed. Significant extra costs arise if the materials have to be diverted or re-handled - for example, if a late change order is issued. Hence, most steelwork contractors will only issue steel for fabrication when the detailed fabrication drawings are complete and approved. If a subsequent change order is issued, they will generally only implement this after the component has completed its passage through the workshop – perhaps waiting until it reaches site to avoid disrupting the pre-planned delivery sequence.

The implications of such changes are thus potentially disruptive to progress and costly out of proportion to their apparent importance. To drill a hole on site would typically cost 10 to 100 times as much as one executed on automatic machinery in the workshop.

2.3 Assembly and Welding

Assembly and welding requires skilful operatives and will generally be the largest element of the fabrication costs. The skills needed are:

- To fabricate compound members such as plated girders and lattice trusses.
- To fit connections onto main members so that they can be joined on site.

As illustrated, accurate 3D fit-up on site will depend fundamentally on the assembly and welding skills deployed during fabrication.



To be economic, welded connections need to be readily accessible for welding and inspection. Having to execute a weld in the overhead or vertical positions will also increase the cost per run considerably. Generally fillet welds are preferred up to 12 mm leg length, and for a tee-butt, two suitably-sized symmetrically-placed fillets are cheaper than a full penetration butt weld.

2.4 Type of Structure

Different types of building structure involve different mixes of work. The following table illustrates what affects costs for typical structural types.

Structural Type (based on RQSC categories)	Rough Guide to Mix of Fabricated Rate per Tonne				Total
	Material	Processing & Handling	Assembly & Welding		
			Compound Members	Connections	
Heavy industrial plant structures	300	150	250	100	800
High rise buildings	350	150	50	150	700
Large span portals	350	150	50	100	650
Medium/small buildings	300	200	0	100	600
Large span trusswork	300	150	200	100	750
Major tubular trusswork	450	150	250	150	1000
Towers	300	200	0	100	600
Frames for machinery & conveyors	300	200	50	150	700
Grandstands & stadia	350	150	100	150	750

Modern buildings often utilise composite action between steel beams and in-situ concrete slabs. Designs that use plain beams in such a way are usually more economic than truss designs. Most lattice frames are "joint-critical" such that their chord and internal sizes may be constrained by

design of their joints – especially if these are to be detailed without expensive stiffening.

Special equipment is needed for preparing CHS truss members, but tubular trusses using RHS or SHS can be detailed with straight cuts only.

3 Material and Components

The materials used in fabrication are of four main types:

- Steel products, mainly sections and plate rolled to BS EN 10025 (see chapter 7).
- Fasteners, mainly bolt assemblies (see chapter 10).
- Weld metal (see chapter 9)
- Specialist items such as tie bars, machined connectors and other machined components.

Steel products are only sourced direct from the rolling mill if the quantity of a given size and grade is sufficient. Otherwise they are sourced through steel stockholders who offer a wide range of "off-the-shelf" profiles. As these are generally in standard lengths there may be some additional cutting wastage, but a steelwork contractor may have a long-term partnering arrangement with a stockholder whereby:

- The stockholder takes the risk of cutting wastage by delivering materials that are cut-to-length.
- The materials are delivered to the fabrication works on a "just-in-time" basis to reduce the steelwork contractors need for working capital.
- The materials may be pre-treated or pre-prepared in other ways (eg plates profiled and drilled).



Fasteners are sourced from specialist stockholders who generally offer fasteners to the whole range of mechanical engineering industries. Structural fasteners are at the heavy end of the range and are provided to particular product standards. It should be noted that fasteners made for other mechanical engineering applications may be inappropriate for structural use (eg the surface treatment used on the fastener may cause changes that are detrimental).

Weld metal is sourced from another set of specialist suppliers who generally supply the whole range of welding equipment. Matching of the welding consumables to the equipment is important as mismatching can cause welding quality defects.

Many prestige structures (such as the Cardiff Millennium Stadium illustrated below) are fabricated

with connections or members that are aesthetically important. For example, cast steel nodes or stainless steel tie bars may be used. The sources of these specialist components are generally precision engineering workshops with sufficiently large lathes, milling machines etc. To ensure that suitable equipment is available, designers need to open a dialogue as early as possible with steelwork contractors who know such firms.



4 Preparation

Processes used to cut and shape steel components prior to assembly either cut by mechanical means (eg sawing) or by chemical means (particularly burning). Burning is generally cheaper and has traditionally been less accurate than mechanical methods. However, burning using an oxy-gas flame is giving way to more accurate thermal methods such as plasma and laser cutting, and these can produce cut surfaces that are more accurate, smoother and less hard. As illustrated burning is now undertaken by accurate CNC machines.



The following illustrations show the most common mechanical processes used: sawing, drilling and punching/cropping. Recent changes to BS 5950-2, the execution standard for steel structures, have allowed punching and cropping to be used for a wider range of thicknesses and this has improved the economy of fabrication. Fittings for connections are more efficiently

produced if the range is rationalised by using a limited range of flats and angles. Adopting the standard details given in the "Green Books" will assist considerably with rationalisation.

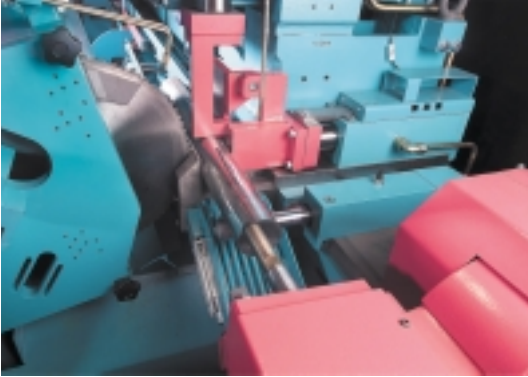

4.1 CNC Equipment

Modern CNC fabrication equipment is more effective with:

- (i) Single end cuts, arranged square to the member length. This eliminates the set up time that would be needed when changing to another angle of cut.
- (ii) One hole diameter on any one piece (eg 22 mm for M20 bolts). This avoids the need for drill bit changes.
- (iii) Alignment of holes on an axis square to the member length, holes in webs and flanges aligned. This reduces the need to move the member between drilling operations.
- (iv) Web holes having adequate side clearance to the flanges for the drill chuck.



4.2 Bending

Prior to final assembly there may be a need to undertake other preparation processes, such as bending. Curved metal members were first used in the mid 19th Century for railway stations and shopping arcades. These were generally made from wrought iron although some members were cast to achieve a curved shape. In the early 1980's there was a return to the use of curved steel in construction as the bending techniques to curve universal beams about the strong axis were developed. As in the 19th Century, the demand is for the structure to express aesthetic features, and this occurs where people congregate in airport terminals, superstores, and leisure facilities.

The design allowances to be made when using curved members are explained in the *Design of Curved Steel* and copies are available from the principal bending companies, Barnshaw Steel Bending Group and The Angle Ring Company Ltd. This publication covers the theory and also gives examples of curved steel in use including:

- Members curved in elevation, eg curved roof beams, three pin arches
- Portal frames with curved rafters
- Ellipse shapes in elevation
- Members curved in plan, eg curved balcony members
- Two pin curved lattice arch structures.

The use of curved members in a structure can greatly enhance its appearance. For example, in portal frame sheds curved rafters eliminate the need for fabricated apex jointing and also roof cladding capping details which both offset the small

additional cost of curving the rafters. Generally speaking if curved roofs are kept over 35m radius trapezoidal sheeting will follow the roof profile without any special curved sheet requirement.

All universal beams supplied by Corus and also Euronorm profiles can be curved as well as most CHS, RHS and SHS profiles. Bending can also be used for plates, eg for tubular mast structures. Plates are either press-braked shapes or rolled as cylinders and can reduce the amount of expensive welding. Advice can be obtained from the bending companies and the minimum radii possible are listed on Barnshaw's web site.



5 Assembly and Welding

As explained in the historical section, assembly of structural steel fabrications evolved during the steam age from the manufacture of boilers and ships. As these were assembled from a series of plates, the term "plating" was retained to describe the process – even when applied to a truss made nearly entirely of sections not plates.

The processes used in welding of structural steelwork are described in chapter 9. There are two key skills needed to ensure successful fabrication:

- Control of distortion during welding.
- Elimination of welding defects.

5.1 Distortion Control

When metal is heated it expands and as it cools it shrinks, but it will not in general shrink back to its exact original shape as the rate of cooling will differ locally from the rate of heating. Thick plates heat up slowly and act to restrain the shape changes of thinner attached plates as they heat up and cool in turn.

For this reason, the plater sometimes has to incorporate presets into the assembly process to counter later distortion from shrinkage after welding. This will be the case for complex plated weldments (eg connections needing extensive local stiffening) or for heavily welded sections (eg joints in trusses made from CHS).

The effect of distortion is far less significant with simple connections used in medium/small beam-and-column and portal-framed structures. Also, such work is repetitive and hence experience may be learned and transferred, and any allowances needed quickly become part of the process. The outcome is that the fabricators can offer standard tolerances for such work in the form of permitted deviations for accuracy of fabrication given in the NSSS. The NSSS characterises the "process capability" of the industry. The limits set are also generally sufficient to allow erection to be completed within the necessary accuracy specified in the NSSS for structural stability (see chapter 14 for further information on as-erected tolerances).

Control of distortion in more complex weldments and heavily-welded sections may require prior analysis, particular sequencing of welding operations and even changes of details. Detailed advice is available from Lincoln Electric's "bible", The Procedure Handbook of Arc Welding. Although that reference gives empirical formulae for transverse shrinkage, angular distortion and longitudinal distortion, some uncertainty about the outcome may remain. For this reason, it is a wise precaution to carefully measure the effects on the first example when, say, several similar trusses are to be produced. Mock-ups and trials can also be used to reduce the chance of excessive distortion occurring late in the production sequence.

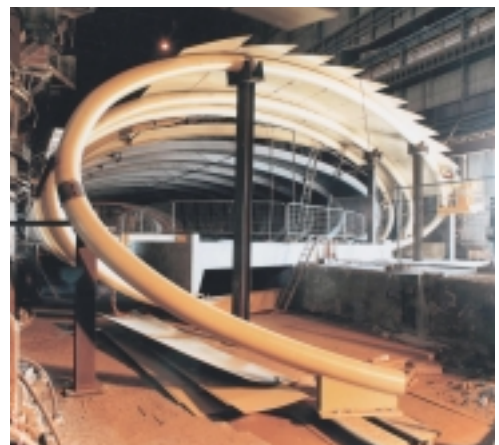

5.2 Welding Defects

The nature of welding is that it is likely to include "imperfections". The skill is to ensure that these imperfections are sufficiently minor as not to become "defects", whereby they would impair the performance of the welded joint. Chapter 9 explains the procedures that are used in this regard, namely prior approval of welder competence and the welding specifications to be used. In the end acceptance criteria are needed to determine when an imperfection has become a defect.

With the exception of buildings that house cranes or other large items of mechanical plant, there is rarely a concern that dynamic loading in welded joints could lead to premature fatigue failure of components in building structures. Similarly, small holes leading to porosity in welds are important when welding containment vessels but have far less of an effect in a welded structural joint. To parameterise the acceptance criteria for structural welds to the required structural performance, the BCSA commissioned the Welding Institute [TWI] to establish fitness-for-purpose criteria for production welds. These were first published in the earlier editions of the NSSS and are now included in BS 5950-2.

Even if a defect has been assessed as being outside the criteria for acceptance, it may not always be necessary to repair the weld or scrap the piece. The tables in the NSSS and BS 5950-2 identify what remedial action is necessary; repairs are advised in 12 cases whereas three cases suggest "refer to Engineer". Two of these cases are errors in weld type and linear alignment which could be re-assessed by calculation as acceptable. The other is where lamellar tears have been identified and this may related to the specification and behaviour of the parent material around the weld.

Lamellar tearing is relatively rare these days, whereas in the early days of offshore development in the North Sea it presented some major difficulties. The reason for the improved performance is that weld details were developed that were less prone to tearing, stronger steels are used instead of thicker materials, steel manufacture has reduced the susceptibility of the material to tearing (by reduced sulfur content in particular), and steels can now be specified with enhanced "through-thickness" performance if needed. Advice on how to avoid lamellar tearing by material specification and weld design is available in EC3 Part 1.10. That Part of EC3 also includes rules for selecting steel materials that avoid brittle fracture.

6 Surface Treatment

Chapter 12 gives a detailed review of how corrosion protection may be ensured for structural steelwork. Most steelwork is used internally in buildings in which the atmosphere has very little corrosive effect. The exception in a typical shed might be the posts and frame immediately around an access door that is kept opened frequently in rainy weather; these might require special attention.

Generally, the emphasis is on simple systems that are easy to apply involving spray application after automatic blasting. Many fabrication shops have internal atmospheres that enable the steel to be blast cleaned before fabrication and surface coated afterwards. In such cases the weld areas would require attention before coating, and components that are not too bulky can be re-blasted by passing them through the machine on a slack conveyor. As with the need to reduce double handling, it makes economic sense to keep some components with no welding as these would not require re-blasting.



Access for painting is difficult for double angle or double channel members and these types have now been largely superseded by using SHS/RHS members that reduce the painted area and provide fewer locations for corrosion traps to form.

7 Transport

When considering the design of long, wide and bulky steel components it is always necessary to check the limits on transport first. Otherwise the component may have to be broken down for transport to site and then site-assembled by bolting or welding.

Transport limits on components for shipping long distances abroad are generally set by the capacity of the standard containers that dominate sea-borne traffic routes. Piece-small for site bolting is often the only economic way. Portal rafters and long-span beams can even be given bolted splices to reduce their length for shipping in a 60-foot container. Having split the length it often becomes economic to consider galvanizing when shipping overseas as it has the added advantage of being more robust against damage than equivalent painted coatings.

In the UK there are three transport regimes:

- No notification required – easy.
- Police notification and escort required – difficult.
- Advanced notification required to Ministry – nearly impossible.

7.1 Easy Regime

To ship steelwork without police impediment is easier for long items than wide ones. Lengths up to 18.3 m on the bed of, say, an extendible 60-foot trailer are no problem. Width is no problem up to 2.9 m (except occasionally through Motorway roadworks when lane width has been restricted). These are limits set by the police and are related to manoeuvrability of the delivery vehicle in traffic and the effect on other traffic.

The general height limit is 4.975 m but the trailer bed is usually about 1.7 m high so that leaves only 3.175 m for the load above. This limit is imposed by the physical size of bridges en route rather than any problem with manoeuvrability in traffic. Some Motorway routes were built with enhanced height clearance (eg M62 to Liverpool to facilitate the export of large assemblies), but more probably the height would be more not less restricted than 3.175 m by the off-Motorway links between shop and site. It is wise to ask the steelwork contractor to check this at an early stage as otherwise suspended cables may need re-routing or long diversions arranged. Similarly, there is a need to check on any Motorway roadworks lane-width restrictions.

Triangular space frame truss assemblies are the most difficult to ship - and often their architectural importance will eliminate the possibility of inserting site bolted splices resulting in the need for expensive and time-consuming site welding.

7.2 Difficult Regime

Police notification is required at least two days in advance for long loads beyond 18.3 m up to 27.4 m (90 feet), and wide loads beyond 2.9 m up to 5.0 m. Often the police will not insist on escorting loads that are long and not wide as these cause far fewer manoeuvrability problems.

They will nearly always insist on escorting wide loads, and the notification/escort arrangements must be separately agreed with every police force en route! It is not unknown to be taken so far by one force then held for hours if the next force has an emergency that intervenes. Similarly, most forces will only move escorted loads during the day, but the Metropolitan Police will generally only move loads at night (which would seem more sensible generally). Hence, not only can loads take several days to move from a fabrication works in a more remote area into London, but the timing can be unpredictable. This can cause major expense and contractual wrangling if special cranes are waiting to lift the large load into place.

In simplest terms, try to avoid triangular trusses, design shop-assembled trusses to within 2.9 m depth and never exceed 5.0 m depth. Always

remember that these dimensions are not boom centre-to-centre dimensions, they are overall - including cleats for attachments. The police do measure and if there is a problem of even a few millimetres the load could be stopped until the offending cleat is removed.

Roll-on/roll-off ferries are generally used when shipping to or from France and elsewhere in Europe. The choice of ferry route (and the particular ferry or ro-ro berth) may set further restrictions. When moving through France, the system is centralised and "licensed contractors" book transport movements in advance. Once you have bought one of these slots, the loads are generally self-escorted by the licensed contractor and through-movement is much quicker as it is not held up at police force boundaries.

7.3 Nearly Impossible Regime

Permission to move a load beyond these length and width limits can be sought at least eight weeks in advance from the Ministry. They will usually refuse unless there is a compelling reason why the structural component cannot be broken down. As this is very rarely the case with a structure (cf a works-tested pressure vessel), it is rarely worth even applying. Furthermore, even if permission is given the restrictions on timing may prove impossible for the fabrication shop to comply with - given the uncertainty about weld testing results etc.

In simplest terms, never design a load that needs Ministry permission to move it. In extremis, other methods can be found, and an example of this is the use of a nearby assembly yard and movement between yard and site that does not require the use of public roads - by means of floating crane or barge perhaps for waterside sites (as illustrated).



CHAPTER 12

Corrosion Protection

By Chris Dolling and Roger Hudson, Corus Plc

1 Introduction to Corrosion

1.1 Corrosion Reaction

The corrosion of steel is an electrochemical process that can be represented the following equation:

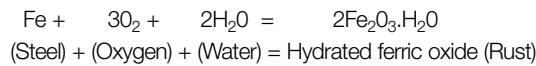

The process requires the simultaneous presence of water and oxygen. In the absence of either, corrosion does not occur.

1.2 Corrosion Rates

The principal factors that determine the rate of corrosion of steel in air are:

'Time of wetness'

This is the proportion of total time during which the surface is wet, due to rainfall, condensation etc. For unprotected steel in dry environments (eg inside heated buildings), corrosion will be negligible due to the low availability of water. The requirement for the application of paints or coatings becomes unnecessary other than for appearance or fire protection purposes.

'Atmospheric pollution'

The type and amount of atmospheric pollution and contaminants (eg sulphates, chlorides, dust etc)

- Sulphates
These originate from sulphur dioxide gas that reacts with water or moisture in the atmosphere to form sulphurous and sulphuric acids. Industrial environments are a prime source of sulphur dioxide.
- Chlorides
The highest concentration of chlorides is to be found in coastal regions and there is a rapid reduction moving inland. In the UK there is evidence to suggest that a two kilometre strip around the coast can be considered as being in a marine environment.

Both sulphates and chlorides increase corrosion rates. They react with the surface of the steel to produce soluble salts of iron, which can concentrate in pits and are themselves corrosive.

Within a given local environment, corrosion rates can vary markedly, due to effects of sheltering and prevailing winds etc. It is therefore the 'micro-climate' immediately surrounding the structure, which determines corrosion rates for practical purposes.

Atmospheric corrosivity categories and examples of typical environments (BS EN ISO 12944-2)

Corrosivity category and risk	Low-carbon steel thickness loss in microns per year	Examples of typical environments in a temperate climate (informative only)	
		Exterior	Interior
C1 very low	<= 1.3	-	Heated buildings with clean atmospheres, eg offices, shops, schools, hotels.
C2 low	> 1.3 to 25	Atmospheres with low level of pollution. Mostly rural areas.	Unheated buildings where condensation may occur, eg depots, sports halls.
C3 medium	> 25 to 50	Urban and industrial atmospheres, moderate sulphur dioxide pollution. Coastal areas with low salinity.	Production rooms with high humidity & some air pollution, eg food-processing plants, laundries, breweries, dairies.
C4 high	> 50 to 80	Industrial areas and coastal areas with moderate salinity.	Chemical plants, swimming pools, coastal, ship and boatyards.
C5-I very high (industrial)	> 80 to 200	Industrial areas with high humidity and aggressive atmosphere.	Buildings or areas with almost permanent condensation and high pollution.
C5-M very high (marine)	> 80 to 200	Coastal and offshore areas with high salinity.	Buildings or areas with almost permanent condensation and with high pollution.

1. The thickness loss values are after the first year of exposure. Losses may reduce over subsequent years.
2. The loss values used for the corrosivity categories are identical to those given in ISO 9223.
3. In coastal areas in hot, humid zones, the mass or thickness loss can exceed the limits of category C5-M. Special precautions must therefore be taken when selecting protective paint systems for structures in such areas.
4. 1 micron = 0.001mm.

Because of variations in atmospheric environments, corrosion rate data cannot be generalised. However, environments can be broadly classified, and corresponding corrosion rates are broadly classified in BS EN ISO 12944-2 and ISO 9223, as illustrated in the table on the previous page.

2 The Influence of Design on Corrosion

In external or wet environments design can have an important bearing on the corrosion of steel structures.

In dry heated interiors no special precautions are necessary. The prevention of corrosion should therefore be taken into account during the design stage of a project. BS EN ISO 12944-3 provides details of designing for the prevention of corrosion. The main points to be considered are:

2.1 Entrapment of Moisture and Dirt

Details that could potentially trap moisture and debris should be avoided where possible. Measures that can be taken include:

- Avoid the creation of cavities, crevices etc.
- Welded joints are preferable to bolted joints.
- Lap joints should be avoided or sealed where possible.
- HSFG faying surfaces should be edge sealed after connection.
- Provide drainage holes for water, where necessary.
- Seal box sections except when they are to be hot-dip galvanized.
- Provide for a free circulation of air around the structure.

2.2 Contact with Other Materials

- Avoid, where practical, bimetallic connections or insulate the contact surfaces if necessary – see BS PD 6484.
- Provide adequate depth of cover and correct quality of concrete – see BS 8110.
- Separate steel and timber by the use of coatings or sheet plastics.

2.3 Coating Application

Design should ensure that the selected protective coatings can be applied efficiently. Access to all surfaces to provide both the initial surface treatment, and subsequent maintenance painting is essential. Narrow gaps, difficult to reach corners, and hidden surfaces should be avoided wherever possible. Similarly, clearance between connecting members at junctions should allow access for

coating and inspection. (Note that large flat surfaces are easier to protect than more complicated shapes).

- Lifting lugs or brackets should be provided where possible to reduce damage during handling and erection.
- Avoid using channels with toes upward.
- Arrange angles with the vertical leg below the horizontal.
- Hot-dip galvanizing should not be used for sealed components. Such items should be provided with vent holes and drain holes – see BS EN ISO 14713.
- Adequate access should be provided for paint spraying, thermal (metal) spraying etc see BS 4479-7.

3 Preparing for Corrosion Protection

Surface preparation is the essential first stage treatment of a steel substrate before the application of any coating, and is generally accepted as being the most important factor affecting the total success of a corrosion protection system.

The performance of a coating is significantly influenced by its ability to adhere properly to the substrate material. Residual millscale on steel surfaces is an unsatisfactory base to apply modern, high performance protective coatings, and is therefore removed by abrasive blast cleaning. Other surface contaminants on the rolled steel surface, such as oil and grease, are also undesirable and must be removed before the blast cleaning process.

The surface preparation process not only cleans the steel, but also introduces a suitable profile to receive the protective coating.

3.1 Surface cleanliness

Various methods and grades of cleanliness are presented in ISO 8501-1 = BS 7079-A1. This standard essentially refers to the surface appearance of the steel after hand/power tool cleaning, abrasive blast cleaning and flame cleaning and gives descriptions with pictorial references of the grades of cleanliness.

Hand and Power Tool Cleaning (St Grades)

Surface cleaning by hand tools such as scrapers and wire brushes is relatively ineffective in removing mill scale or adherent rust. Power tools offer a slight improvement over manual methods and these methods can be approximately 30% to 50% effective but are not usually used for new steelwork fabrications. Where it is not possible to clean by abrasive blasting, hand and power tool methods may be the only acceptable alternative methods.

Abrasive Blast Cleaning (Sa Grades)

By far the most significant and important method used for the thorough cleaning of mill-scaled and rusted surfaces is abrasive blast cleaning. This method involves mechanical cleaning by the continuous impact of abrasive particles at high velocities on to the steel surface either in a jet stream of compressed air or by centrifugal impellers. The abrasives are recycled with separator screens to remove fine particles. This process can be 100% efficient in the removal of mill scale and rust. The standard grades of cleanliness for abrasive blast cleaning are:

- Sa 1 - Light blast cleaning
- Sa 2 - Thorough blast cleaning
- Sa 2½ - Very thorough blast cleaning
- Sa 3 - Blast cleaning to visually clean steel

A wide range of abrasives is available. These can be non-metallic (metal slags, aluminium oxide etc) or metallic (steel shot or grit etc). However, the use of sand for blast cleaning is not recommended, and is illegal in the UK, for health and safety reasons.

Other Methods

Other methods of surface preparation include flame cleaning and acid pickling. However, flame cleaning is rarely used and acid pickling is normally only used for structural steel intended for hot dip galvanizing.

3.2 Surface Profile/Amplitude

The type and size of the abrasive used in blast cleaning have a significant effect on the profile or amplitude produced. For example, shot abrasives are used for thin film paint coatings such as pre-fabrication primers, whereas thick or high build paint coatings and thermally sprayed metal coatings need a coarse angular surface profile to provide a mechanical key. The difference between these two examples of blast cleaned surfaces is illustrated below.

The surface treatment specification should therefore describe the surface roughness required, usually as an indication of the average amplitude achieved by the blast cleaning process.

3.3 Surface Dust

The blast cleaning operation produces large quantities of dust and debris that must be removed from the abraded surface. Automatic plants are usually equipped with mechanical brushes and air blowers. Other methods can utilise sweeping and vacuum cleaning. However, the effectiveness of these cleaning operations may not

be readily visible and the presence of fine residual dust particles that could interfere with coating adhesion can be checked by using a pressure sensitive tape pressed onto the blast cleaned surface. The tape, along with any dust adhering to it, is then placed on a white background and compared to a pictorial rating. This method is described in ISO 8502-3 = BS 7079-B3.

3.4 Surface Condition Immediately Before Coating

After the preparation of the surface to an acceptable standard of cleanliness and profile, it is important that the steelwork is not allowed to deteriorate. Re-rusting can occur very quickly in a damp environment and unless the steel is maintained in a dry condition coating of the surface should proceed as soon as possible. Any re-rusting of the surface should be considered as a contaminant and be removed by re-blasting.

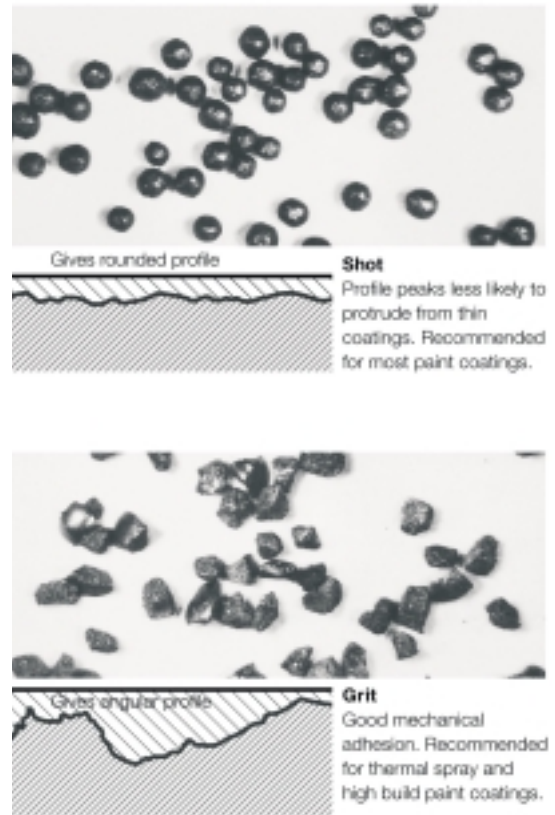

Blast cleaning abrasive particles and steel surface profiles

3.5 Additional Surface Treatments

After abrasive blast cleaning, it is possible to examine for surface imperfections and surface alterations caused during fabrication processes, eg welding, sawing, and flame cutting. Depending upon the specific requirements of the structure, it may be necessary to remove general surface imperfections on welds and cut edges to produce an acceptable surface condition for painting.

Welds must be continuous and free from pinholes, sharp projections and excessive undercutting. Weld spatter and residual slags should also be removed. Sawn and flame-cut edges introduce a localized increase in hardness and roughness that may require removal to ensure that the coating adheres and is of sufficient thickness. Guidance is being drafted in the form of a new standard, ISO/DIS 8501-3.

Soluble Iron Corrosion Products

Depending upon the condition of the steelwork prior to blast cleaning, there may be surface contaminants present other than mill scale and rust. Initial steel surface conditions of the majority of new steelwork are unlikely to be affected, however steelwork that is pitted could contain contaminants within the pits that may not be removed by the dry blast cleaning process, but this is rarely encountered on new works. Methods to remove soluble salts include wet abrasive blast cleaning, and ultra-high pressure water jetting.

4 Paint Coatings

Painting is the principal method of protecting structural steelwork from corrosion. Paint systems for steel buildings have developed over the years in response to technological advancements that have brought improved performance, and more recently to comply with industrial environmental legislation.

4.1 Composition of Paints & Film-formation

Paints are made by mixing and blending three main components: a pigment, a binder, and a solvent. Pigments are finely ground powders, which provide colour, opacity, film cohesion and sometimes corrosion inhibition. Binders are usually resins or oils, but can be inorganic compounds such as soluble silicates. The binder is the film-forming component in the paint. Solvents are used to dissolve the binder and to facilitate application at the paint. Solvents are usually organic liquids or water.

The application of paint to steel surfaces produces a 'wet film'. As the solvent evaporates, film formation occurs, leaving the binder and pigments on the surface as a 'dry film'. Both the wet film and the dry film thickness can be measured, and the relationship between them is determined by the percentage of volume solids in the paint. In general, the corrosion protection afforded by a paint film is directly proportional to its dry film thickness.

4.2 Classification of Paints

Since paint consists of a particular pigment, dispersed in a particular binder, dissolved in a particular solvent then the number of generic types of paint is limited. The most common methods of classifying paints are either by their pigmentation or by their binder type.

4.3 Painting Systems

Paints are usually applied one coat on top of another, and each coat has a specific function. The primer is applied directly onto the cleaned steel surface. Its purpose is to wet the surface, to provide good adhesion for subsequently applied coats, and also usually to provide corrosion inhibition. The intermediate coats (or undercoats) are applied to 'build' the total film thickness of the system, and thus increase the durability of the system. The finishing coats provide the first line of defence against the environment and also determine the final appearance in terms of gloss, colour etc.

The various superimposed coats within a painting system have to be compatible with one another. Therefore, all paints within a system should normally be obtained from the same manufacturer. Designers should specify the generic type of paint and performance criteria, and leave the steelwork contractor to decide which proprietary paint to apply. Many steelwork contractors prefer a single supplier for all their paints.

4.4 Main Generic Types of Paint and their Properties

A summary of the main generic types of paint and their properties is shown on the following page.

Main Generic Types of Paint and their Properties

Binder	System Cost	Tolerance of Poor Surface	Chemical Resistance	Solvent Resistance	Water Resistance	Overcoating After Aging	Comments
Black Coatings (based on tar products)	Low	Good	Moderate	Poor	Good	Very good with coatings of the same type	Limited to black or dark colours. May soften in hot conditions
Alkyds	Low – Medium	Moderate	Poor	Poor - Moderate	Moderate	Good	Good decorative properties. High solvent levels
Acrylated Rubbers	Medium – High	Poor	Good	Poor	Good	Good	High build films that remain soft & are susceptible to sticking
Epoxy Surface Tolerant	Medium – High	Good	Good	Good	Good	Good	Can be applied to a range of surfaces and coatings
Epoxy High Performance	Medium – High	Very Poor	Very Good	Good	Very Good	Poor	Susceptible to 'chalking' in UV light
Urethane & Polyurethane	High	Very Poor	Very Good	Good	Very Good	Poor	Can be more decorative than epoxies
Organic Silicate & Inorganic Silicate	High	Very Poor	Moderate	Good	Good	Moderate	May require special surface preparation

4.5 Prefabrication Primers

These primers are also referred to as blast primers, shop primers, temporary primers, holding primers etc. They are used on structural steelwork, immediately after blast cleaning, to maintain the reactive blast cleaned surface in a rust free condition until final painting can be undertaken. They are mainly applied to steel plates and sections before fabrication, and must be compatible with the intended paint system. Many proprietary prefabrication primers are available but they can be classified under the following main generic types:

- Etch primers (less commonly used)
- Epoxy primers
- Zinc epoxy primers (less commonly used)
- Zinc silicate primers

4.6 Application of Paints

The method of application and the conditions under which paints are applied have a significant effect on the quality and durability of the coating. The standard methods used for applying paints to structural steelwork are brushing, roller, conventional air spray and airless spray, although other methods (eg dipping) can be used. Airless spraying has become the most commonly used method of applying paint

coatings to structural steelwork under controlled shop conditions. Brush and roller application are more commonly used for site application, though spraying methods are also used.

The principal conditions that affect the application of paint coatings are temperature and humidity. These can be more easily controlled under shop conditions than on site.

4.7 Environmental Protection

The specification for paint coatings should comply with the Environmental Protection Act (1990), and the Secretary of State's Process Guidance Note PG6/23 'Coating of Metal and Plastic'. Further guidance is available from paint manufacturers' data sheets.

5 Metallic Coatings

There are four commonly used methods of applying metal coating to steel surfaces. These are hot-dip galvanizing, thermal spraying, electroplating and sherardizing. The latter two processes are not used for structural steelwork but are used for fittings, fasteners and other small items. In general the corrosion protection afforded by metallic coatings is largely dependent upon the choice of coating metal and its thickness and is not greatly influenced by the method of application.

5.1 Hot-dip Galvanizing

The most common method of applying a metal coating to structural steel is by hot-dip galvanizing.

The galvanizing process involves immersing the steel component to be coated in a bath of molten zinc after pickling and fluxing, and then withdrawing it. The immersed surfaces are uniformly coated with zinc alloy and zinc layers that form an integral bond with the substrate as illustrated here.

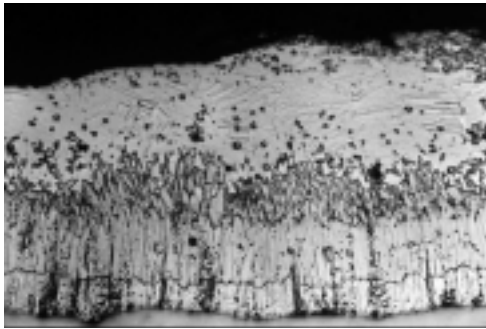

Cross-section through a typical hot-dip galvanized coating

As the zinc solidifies, it usually assumes a crystalline metallic lustre, often referred to as spangling. The thickness of the galvanized coating is influenced by various factors including the size and thickness of the workpiece, the steel surface preparation, and the chemical composition of the steel. Thick steel parts and steels which have been abrasive blast cleaned tend to produce relatively thick coatings.

Since hot-dip galvanizing is a dipping process, there is obviously some limitation on the size of components that can be galvanized. However, 'double-dipping' can often be used when the length or width of the workpiece exceeds the size of the bath.

The specification of hot-dip galvanized coatings for structural steelwork is currently covered by BS EN ISO 1461.

Some aspects of the design of structural steel components need to take the galvanizing process into account, particularly with regard the ease of filling, venting and draining and the likelihood of distortion. To enable a satisfactory coating, suitable holes must be provided in hollow sections to allow access for the molten zinc, the venting of hot gases, and the subsequent draining of zinc. Further guidance on the design of articles to be hot dip galvanized can be found in BS EN ISO 14713. The suitability of steels for hot dip galvanizing should also be checked with the supplier.

Instances of cracking have been associated with the hot-dip galvanizing process. Guidance on such potential problems is available from the BCSA and the Galvanizer's Association.

5.2 Thermal Spray Coatings

In thermal spraying, either zinc or aluminium can be used. The metal, in powder or wire form, is fed through a special spray gun containing a heat source, which can be either an oxygas flame or an electric arc. Molten globules of the metal are blown by a compressed air jet onto the steel surface.

No alloying occurs, and the coating that is produced consists of overlapping platelets of metal and is porous as illustrated below. The adhesion of sprayed metal coatings to steel surfaces is considered to be essentially mechanical in nature. It is therefore necessary to apply the coating to a clean roughened surface and blast cleaning with a coarse grit abrasive is normally specified.

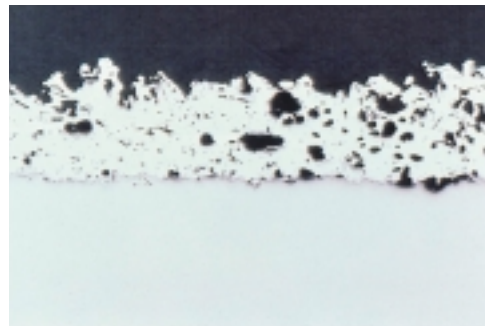

Cross-section through a thermally sprayed aluminium coating.

The pores are subsequently sealed, either by applying a thin organic coating that penetrates into the surface, or by corrosion products which form during exposure. Typically specified coating thicknesses vary between 100-200 μm (microns) for aluminium, and 100-150 μm for zinc.

Thermal spray coatings can be applied in the shops or at site, there is no limitation on the size of the workpiece, and the steel surface remains cool so there are no distortion problems.

The protection of structural steelwork against atmospheric corrosion by thermal sprayed aluminium or zinc coatings is covered in BS EN 22063, and guidance on the design of articles to be thermally sprayed can be found in BS EN ISO 14713.

5.3 Fasteners (Bolts, Nuts and Washers)

The exposed surfaces of bolted fasteners need to be protected to at least the same level as the primary members of steelwork. Indeed the crevices associated with these fasteners are particularly vulnerable. Hot-dip galvanized fasteners should be specified in accordance with BS 7371-6.

Paint coatings are sometimes applied over metal coatings to provide extra durability or for decorative purposes. The combination of metal and paint coatings is usually referred to as a "Duplex" coating.

6 The Protective Treatment Specification

The specification is intended to provide clear and precise instructions to the contractor on what is to be done and how it is to be done. It should be written in a logical sequence, starting with surface preparation, going through each paint or metal coat to be applied and finally dealing with specific areas, eg welds. It should also be as brief as possible, consistent with providing all the necessary information. The most important items of a specification include:

- The method of surface preparation and the standard required, eg BS 7079-A1 Grade Sa 2 1/2.
- The maximum interval between surface preparation, and subsequent priming.
- The types of paint or metal coatings to be used.
- The method/s of application to be used.
- The number of coats to be applied and the interval between coats.
- The wet and dry film thickness for each coat.
- Where each coat is to be applied (ie shops or site) and the application conditions required, in terms of temperature, humidity etc.
- Details for treatment of welds, connections etc.
- Rectification procedures for damage etc.

Guidance on selecting an appropriate protective treatment specification is available from Corus in its publication '*The prevention of corrosion on structural steelwork*'.

7 Inspection

The employment of an appropriately qualified paint and coating inspector is an essential requirement to monitor for compliance with the specification, record essential data and advise where any non-conformances are found. Ideally, this inspection should be carried out throughout the course of the contract at each separate phase of the work, ie surface preparation, first coat, second coat etc.

An inspector qualified ideally to a minimum of Level 2 of the Institute of Corrosion Inspector certification scheme is recommended. This international scheme is available for the qualification and certification of industrial painting and coating inspectors and operates in accordance with EN 45013 = BS 7513.

CHAPTER 13

Fire Resistance

By John Dowling, Corus Construction & Industrial

1 Legal Requirements

Provision for structural fire resistance of buildings is embodied in Part B of Schedule 1 of the Building Regulations 1991 as follows:

"The building shall be designed and constructed so that, in the event of a fire, its stability will be maintained for a reasonable period."

In England & Wales this requirement is interpreted in Approved Document B which states that the stability criterion will be satisfied if *"the load bearing elements of the structure of the building are capable of withstanding the effects of fire for an appropriate period without the loss of stability."* The Approved Document contains detailed provisions for the maintenance of structural stability in fire along with guidance on appropriate periods. These are intended to provide guidance for some of the most common building situations and vary according to building height and occupancy.

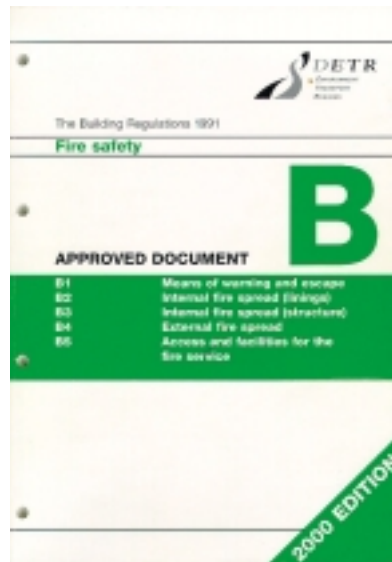

England & Wales: Approved Document B

The requirements of Approved Document B are not mandatory and it contains the statement that: *"There is no obligation to adopt any particular solution ... if you prefer to meet the relevant requirement in some other way."* Guidance of 'other ways' is given as: *"Fire safety engineering can provide an alternative approach to fire safety. It may be the only viable way to a satisfactory standard of fire safety in some large and complex buildings and in buildings containing different uses."*

In practice, Approved Document B is used as the source of information on fire precautions in most buildings. Structural fire resistance requirements vary according to the building occupancy and height and are a minimum and maximum of 30 and 120 minutes respectively. Open-sided car parks are a special case requiring a nominal 15 minutes fire resistance; this can be achieved without protection by most of the Universal Beam and Column range. A summary of structural fire resistance requirements from the Approved Document is provided in the following table.

Approved Document B 2000	Height of Building (m)			
	<5	<18	30	>30
Residential (Non Domestic)	30	60	90	120 + Sprinklers
Offices	30	60	90	
Shops, Commercial, Assembly	60	60	90	
Industrial & Storage	60	90	120	
Car Parks - Closed	30	60	90	
Car Parks - Open	15	15	15	

Figures in yellow box may be reduced by 30 minutes when an approved life safety sprinkler system is installed if sprinklers are installed

Structural fire resistance requirements given in Approved Document B

In Scotland, compliance is required with Part D of the Technical Standards of the Building Regulations. It is not necessary to follow the requirements if one can demonstrate that an alternative method meets the requirement of the functional standard, which is similar to that for England & Wales. A relaxation of the requirements given in Technical Standard D is possible where alternative methods of fire protection can be shown to give equivalent levels of safety to those in the standard. Compensatory features may be required. Fire resistance requirements are based on building height and occupancy but also on floor area and level of risk.



Scotland: Technical Standards Part D

In Northern Ireland, the fire safety requirements of the Building Regulations are supported by Technical Booklet E which contains provisions similar to those in Approved Document B. Alternative approaches are allowed although, unlike Approved Document B, the provisions are deemed to satisfy the requirements of the Building Regulations.



Northern Ireland: Technical Booklet E

A number of other sources of information on fire resistance requirements are also available. The most widely used are listed among the references to this chapter.

2 Fire Safety Engineering

Fire safety engineering (or fire engineering as it is often termed) can be seen as an integrated package of measures designed to achieve the maximum benefit from available methods for preventing, controlling and limiting the consequences of fire. In terms of structural stability, fire safety engineering is aimed at adopting a

rational scientific approach which ensures that fire resistance/protection is provided where it is needed rather than accepting universal provisions which may over or under estimate the level of risk. Although a relatively new science, fire safety engineering has been vigorously developed in the UK and this country can now lay claim to world leading expertise.

Fire safety engineering is used on a wide range of structures and many notable buildings across the UK have been designed in this way. Typical of the situation where it is of considerable benefit are sports stadia. Most stadia can no longer be described as simple steel, concrete and blockwork structures for the sole purpose of watching sports. Instead they are usually mixed-occupancy buildings, often containing shops, restaurants and gymnasia, which creates difficulties in developing fire safety policies consistent with those laid out in sources such as Approved Documents. Fire safety engineering usually allows a resolution to this dilemma. In essence they are cases where, as Approved Document B states, fire safety engineering may be the only way of satisfying the regulations.

The illustrations here are examples of the types of building where fire safety engineering has achieved considerable client value.



Newcastle United Ground. Fire Engineers FiSec



Swiss Re Building. Fire Engineers Arup Fire.



Nuffield Hospital Leeds. Fire Engineers FEDRA

BS 7974 provides "a framework for an engineering approach to the achievement of fire safety in buildings." It is accompanied by a series of eight Published Documents [BS PDs] detailing the approach which should be followed when carrying out a fire safety engineering assessment. The two published documents of most relevance to steel construction, PD3 and PD7, cover structural design and risk assessment.

3 Passive Fire Protection Methods

Passive fire protection methods are widely used to insulate steel structures from the effects of high temperatures which may be generated in fire. They can be divided into two types, non-reactive, of which the most common are boards and sprays, and reactive, of which the best known are thin film intumescent coatings. [Note that the term reactive distinguishes such methods from "active" methods such as sprinklers.]

Boards are still the most common form of fire protection for structural steelwork in the UK. Rigid boards offer a clean boxed appearance which may be pre-finished or suitable for further decoration. Cheaper, non-aesthetic boards are available where appearance is not important.



Board protection

Spray protection systems are still the cheapest form of fire protection and they have the further advantage of being able to take the shape of complex details. They are generally not used where aesthetics are important and suffer from problems with overspray, a particular difficulty in tall buildings and/or congested areas.

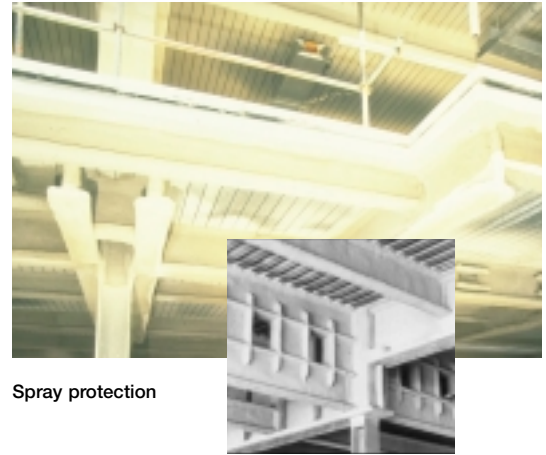

Spray protection

Thin film intumescent coatings are paint-like materials which are inert at low temperatures but which swell (or tumesce) to provide a charred layer of low conductivity foam when exposed to high temperatures. They are widely used where aesthetics are important although reductions in price have led to significant increases in general application in recent years. Complex shapes can also be easily covered. In terms of cost, they are equivalent to a board when applied by a reputable contractor. Cost increases exponentially with thickness, however, and intumescents are rarely used to provide fire resistance greater than 90 minutes. Most site-applied intumescents are water based; solvent-based materials are mainly used for off-site application.



Intumescent coating

Materials such as concrete, blockwork, plasterboard etc are also used on occasion to provide fire protection to structural steelwork.

An annual survey carried out by Corus has identified that boards and intumescent coatings command the majority of the structural fire protection market, upwards of 70%. Sprays have a 15-20% market share with the remainder being taken by other methods.

4 Off-Site Fire Protection

Off-site fire protection, usually using solvent-based thin film intumescent coatings, is increasingly used in the UK. This is particularly the case in buildings requiring 30, 60 and 90 minutes fire resistance, on sites with restricted access or where speed of construction is of considerable importance.

The process offers a number of specific advantages:

- Quicker construction time.
- Removing a major trade off the construction path.
- Simplifying the installation of services.
- Ensuring high standards of finish, quality and reliability.
- Eliminating site access and weather problems.
- Removing the need to segregate or quarantine areas for fire protection application.

Off-site fire protection has developed considerably since it originally began to be used on a large scale in the mid 1990's. By 2003 it was estimated to command 15% market share in new build multi-storey construction.



Off-site intumescent coatings are applied manually in large, heated sheds with good air movement

5 Inherent Fire Resistance

Standard fire tests have shown that structural members that are not fully exposed to fire can exhibit substantial levels of inherent fire resistance without applied fire protection. Methods have been developed which use this effect to achieve 30 and 60 minutes fire resistance. Where longer periods are called for, this can be achieved by applying protection to the exposed steelwork only.

Block-infilled columns can achieve 30 minutes fire resistance by the use of autoclaved, aerated blocks cemented between the flanges and tied to the web of rolled sections.



Block-filled column providing 30 minutes fire resistance

Web-infilled columns achieve 60 minutes fire resistance where normal weight, poured concrete is fixed between column flanges by shear connectors attached to the web. The concrete is retained by a web stiffener fixed at the bottom of the connection zone.

Shelf angle floor beams use angles attached to the web to support a precast floor slab. The level of insulation provided increases as the angle is moved down the web and it is possible, particularly in lightly-loaded beams to achieve 60 minutes fire resistance without additional protection.



Shelf angle floor beam

The most widely used of the partial protection systems is Slimdek which uses an asymmetric beam to support a deep metal deck on the bottom flange. The beam is effectively built into the floor and this provides up to 60 minutes fire resistance.

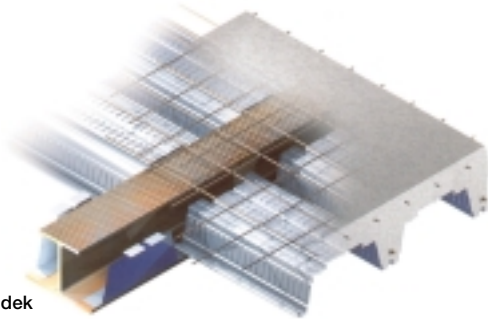

Slimdek

Hollow sections can achieve up to 120 minutes fire resistance without fire protection by filling with concrete and using some reinforcement. Filling with concrete alone can also create a sufficient heat sink that allows significant reductions in intumescent coating thickness when using externally applied protection.

A number of buildings have made use of these methods to achieve 60 minutes fire resistance without applied protection. A case study, the Technology Partnership Development, is included amongst the chapter references.

6 Cardington Fire Tests and Design Guidance

Between 1994 and 2003, a series of seven fire tests were carried out on an eight storey steel framed, composite metal deck building at the Building Research Establishment facility at Cardington. The purpose of the tests was to validate the experience of previous actual fires in similar buildings during which no collapse had taken place. The object was to identify that frames of this type had significantly greater reserves of strength than is indicated by tests on individual elements, the usual source of information on structural performance.

In the tests, columns were protected but beams were not. In spite of atmosphere and steel temperatures of over 1200°C and 1100°C respectively, no collapse took place.

It was determined that, as the unprotected steel beams lost much of their load carrying capacity in the fire, the composite slab was utilised at its ultimate capacity in spanning between the adjacent cooler members. This behaviour commences as a "compressive membrane" or arching effect, and with increasing displacements, the slab adopts a catenary behaviour as a "tensile membrane" with the loads being carried in the reinforcement which then became the critical element of the floor construction.

The BRE devised a simple structural model which combines the residual strength of steel composite beams with the slab strength calculated using a combined yield line and membrane action model designed to take into account the enhancement to slab strength from tensile membrane action. The Steel Construction Institute has developed this model into a series of tables which have been published as a design guide. Use of these tables allows designers to leave large numbers of secondary beams unprotected in buildings

requiring 30 and 60 minutes fire resistance although some compensating features such as increased mesh size and density may be required.



Project "Time" showing unprotected secondary beams in composite metal deck construction

7 Codes of Practice

The most widely used design code for steel in fire in the UK is BS 5950-8. First published in 1990 and revised in 2003, this document brings together generic information on methods of achieving fire resistance for structural steelwork.

The development of the Eurocodes will see the introduction of three standards to take the place of BS 5950-8. Although these will be common standards throughout Western Europe, they will contain nationally determined values for critical parameters. These will be varied in different countries and will be contained in National Annexes.

They are to be:

EC1 Part 1.2 (EN 1991-1-2): This document outlines methods of calculation of heating rates and exposure to fire. It was published in late 2002 and it is expected that the National Annex will be completed in 2004.

EC3 Part 1.2 (EN 1993-1-2): A formal vote took place in 2003. The National Annex is expected to become available in 2004. It covers design of non-composite structural steelwork in fire.

EC4 Part 1.2 (EN 1994-1-2): A formal vote took place in 2003. The National Annex is expected to become available in 2004. It covers design of composite structural steelwork in fire.

8 Reinstatement of Fire Damaged Structures

All materials weaken with increasing temperature and steel is no exception. A modern Grade S275 hot rolled structural steel section, subjected to fire conditions that raise its temperature over 600°C, may suffer some deterioration in residual properties on cooling. For yield stress or tensile strength however, any residual loss is unlikely to be greater than 10%. Higher strength steels, such as S355 may suffer greater proportional losses in properties if heated above 600°C. This is because such

steels obtain their characteristics by the addition of strengthening elements. At high temperatures, these tend to precipitate out of the matrix creating a coarse distribution.

At 600°C, the yield strength of steel is equal to about 40% of its room temperature value. It follows therefore that any steel still remaining straight after the fire and which has been carrying an appreciable load, was probably not heated beyond 600°C, will not have undergone any metallurgical changes and will probably be fit for re-use. Nevertheless, it is recommended that hardness tests are always carried out and, for high strength steels, additional tensile test coupons should be taken from the fire affected zone.

Bolts should always be replaced if they show any sign of having been heated (eg blistering paint or a smooth grey scaled surface). Special care should also be taken to inspect connections for cracking of welds, end plate damage, bolt failure etc. A number of bolts should be removed for inspection. Similar care should be taken when inspecting foundations.

The references for this chapter include one that gives full details of the precautions outlined.

9 Single Storey Buildings in Fire

In the UK, roofs and elements supporting only a roof are exempted from the list of elements of structure requiring verification in the fire limit state. Consequently, single storey buildings do not normally require fire protection. Exceptions may occur where the structural elements:

- form part of a separating wall,
- support a compartment wall or the enclosing structure of a protected zone,
- support an external wall which must retain stability to prevent fire spread to adjacent buildings (ie a boundary condition),
- support a gallery or a roof which also performs the function of a floor (eg a car park or means of escape).

The most frequent of these four scenarios in which fire protection is required is the boundary condition. In this situation, it is widely accepted that it is sufficient for only the stanchions supporting the walls designated as forming the boundary to be fire protected. The rafters may be left unprotected but the stanchion base must be designed to resist the overturning moments and forces caused by rafter collapse in fire. The method of calculation used to derive the horizontal forces and moments caused by rafter collapse is given in the Steel Construction Institute publication *Single Storey Steel Framed Buildings in Fire Boundary Conditions*. [Note: This succeeds a previous publication *Portal Frames in Boundary Conditions*.] This document also outlines what are considered reasonable approaches where the building incorporates internal two-storey parts, compartmentation and lean-to structures.

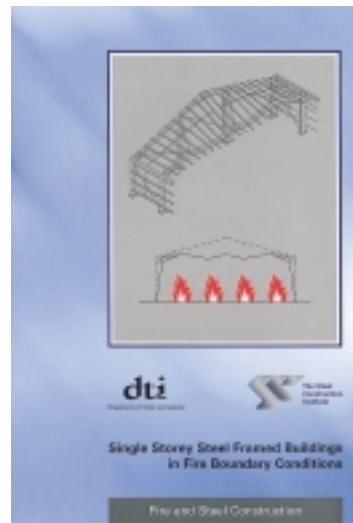

Single Storey Steel Framed Buildings in Fire Boundary Conditions

10 Use of Sprinklers

Provision of active fire protection systems is mandatory in most buildings over 30 metres in height in England, Wales and Northern Ireland. Some other types of building, in particular large retail buildings, may also require sprinklers in addition to passive fire protection. Because the Building Regulations exist to protect life rather than property, sprinkler systems deemed to be mandatory or which are installed to take advantage of relaxations in other requirements must be life safety systems and as such require significant additional safety features over those required purely for property protection. These are outlined in BS 5306-2.

The situations where relaxations in structural fire resistance requirements are allowed when a life safety sprinkler system is installed are given in the table above. Other relaxations possible in multi-storey buildings where life safety sprinklers are installed include increases in floor area for some occupancies and reductions in the number of fire fighting shafts (if required). Reductions in insurance premiums are also possible when sprinklers are installed, although competitive pressures in the insurance industry in recent years have meant that this is may not necessarily reflect the full benefits.

In practice, a very limited number of situations exist in the UK where it is possible to make the available trade-offs cost effective against the costs of a life safety sprinkler system. It does occur however and good examples are given in British Automatic Sprinkler Association Publications.

Considerable benefit can be gained from sprinkler protection systems when carrying out a fire engineering assessment, particularly in situations where they are mandatory. In such cases, the sprinklers can often be shown to compensate for reductions in fire precautions elsewhere and become the bedrock of the case for demonstrating compliance with the requirements of the regulations (see the examples in this chapter).

CHAPTER 14

Erection

By Roger Pope, BCSA Technical Consultant

1 Introduction

1.1 Design for Construction

Erection of structural steelwork consists of the assembly of steel components into a frame on site. The processes involve lifting and placing components into position, then connecting them together – generally using bolting but sometimes using site welding. The assembled frame needs to be aligned before bolting up is completed.

Often the ability to complete these processes safely, quickly and economically is influenced significantly by early decisions made during design long before erection commences. It is important that designers clearly understand the impact that their decisions can have; "buildability" is a valid design objective. In this context, this chapter draws on the wider advice given in the *Design for Construction* (see chapter references).



1.2 Basics of Erection

Safety is a crucial consideration during steel erection. This is particularly the case as part-erected structures can be vulnerable to collapse, cranes can overturn or drop large components, and also because work on the frame requires erectors to access the structure at heights from which a fall could well be fatal. Chapter 20 explains the importance of arranging stability, craneage and access safely. This chapter concentrates on the mechanics of erection.



Steel erection consists of four main tasks:

- (i) Establishing that the foundations are suitable and safe for erection to commence.
- (ii) Lifting and placing components into position, generally using cranes but sometimes by jacking. To secure components in place bolted connections will be made, but will not yet be fully tightened. Bracings may similarly not be fully secured.
- (iii) Aligning the structure, principally by checking that column bases are lined and level and columns are plumb. Packing in beam-to-column connections may need to be changed to allow column plumb to be adjusted.
- (iv) Bolting-up which means completing all the bolted connections to secure and impart rigidity to the frame.



1.3 Erection Handover

The final objective of the erection process is to handover the frame to following trades in an acceptable condition. The key criterion here is the positional accuracy of the erected frame, and this depends on an understanding of how the erected position of a steel frame is controlled. The following description is an abstract of the Grey Book Commentary to the NSSS.

Alignment

A steel framed structure is a very large assembly of a large number of relatively slender and flexible components. Overall accuracies of approximately 1 part in 1000 are sought for plumb and line of the completed structure, using components that may individually be manufactured with greater variability than 1 part in 1000. In addition, deformations such

as the flexure of the structure under self-weight of steel affect its actual position. A clear understanding is needed of both the concepts involved and the methods used for control of the erected position of a steel frame.

The concepts are set out clearly in BS 6954 [three Parts] *Tolerances for building*, which was pioneered by the Building Research Establishment following the investigative work that led to the publication of what has now become BS 5606: *Guide to accuracy in building*.

Within an inspection and test plan, tests undertaken at handover of an erected steel structure could be considered to be final acceptance tests.

To be meaningful, all tests require the following to be specified: a method of test, the location and frequency of testing, the acceptance criteria and action to be taken if nonconformities are discovered. For erection, this is a difficult area in several ways.

First, the method of test is dimensional survey as described in BS 7307 [two Parts] *Building tolerances*. The accuracy achievable by the survey equipment regularly used on building sites is, at best, 2mm and often no better than 5mm (see BS 7334 [eight Parts] *Measuring instruments for building construction*). Even at best, this means that 5% of the as-measured values could be more than ± 4 mm away from the actual position. Hence, the method of measurement is potentially unable to discriminate between a steel frame that complies and one that does not.

Secondly, the location and frequency of checking might well represent less than a quarter of all main frame connection points. An example would be checking only the perimeter columns in the cross-shop direction at first floor connection.

Thirdly, the normal procedure for alignment of columns by plumbing-up is not a final acceptance test as such. It consists of an interaction between the site engineer using the survey instrument and the erection gang doing the final bolt tightening and shimming. By the progressive use of wedges, jacks, pull-lifts and proprietary pulling devices such as *Tirfors*, the gang persuades the frame to move to a position acceptable to the checking engineer and then bolts it up firmly. Some lack-of-fit is overcome in this process, and some is created. If the latter is adverse, local corrections are made. The team rarely returns to a frame once that it has been checked, plumbed and bolted up.



Acceptance

The cost, difficulty and duration of undertaking a complete three-dimensional survey as a final acceptance test (when the whole steel frame is complete) make it rarely practical. It is also unnecessary if the purpose is to ensure stability of the as-erected structure.

The development of the regime for accepting an as-erected steel frame has been a joint one, shared by the frame builders and the specifying designers. The permitted deviations specified hitherto must be seen in that context. Over the years, designers have often specified values that are targets rather than absolute go/no-go acceptance limits. To support that approach, the design itself assumes significantly greater eccentricities and notional frame imperfections than the deviations permitted. This allows a contingency that can occasionally be used to allow judicious concession when the steel frame cannot be persuaded to plumb up sufficiently accurately.

Moving from a handover process that relies in part on mutual understanding between steelworker and designer to one of absolutes in the hands of strict quality inspectors is difficult. It is made more difficult if there is little background information on the dimensional accuracy of as-built frames, and that which does exist shows that the hitherto specified (target) values are close to, if not beyond the combined process capability of erection combined with site surveying.

Criteria

The solution is to break the problem down into two parts:

- How to ensure stability?
- How to deliver other dimensional requirements specified for interfaces?

For the former, there is no reason to make any fundamental changes to the progressive method described above. Quality can be assured by using three straightforward steps:

- Competent Site engineers who are experienced in steel construction.

- Appropriate metrological control of instruments and benchmarks.
- Care in ensuring that the location and frequency of checks concentrates on key points, such as the 'stiff box'.

For interface requirements, the key is to understand that an as-erected steel frame cannot deliver overall positional dimensions specified in absolute terms to accuracies such as $\pm 10\text{mm}$, without adjustability local to the point of interface. SCI has developed guidance in this area through a series of publications dealing with interfaces. The skill is in assessing how much adjustability is needed to cope with cumulative effects, and ensuring that the inspection and test plan includes appropriate and practical tests of acceptability.

1.4 Site Surveys for Steel Construction

The accompanying box explains the practice used to survey steel structures on site. From this it may be seen that:

- The accuracy of site surveys is constrained by the methods employed and the reference lines and levels provided for the site by the principal contractor.
- Site surveys of the erected structure will focus on the nodes where connections are made on site.
- Between these erection nodes, the position of components will be determined by fabrication tolerances.
- Positions will be affected by deformations, such as self-weight deflection, which may be significant enough to require correction by pre-cambering.



Site surveys for steel construction

To explain the practice used to survey steel structures on site, the following paragraphs, based on adapted extracts from sub-clause 12.7 of DD ENV 1090-1, are included:

Establishment of reference system and survey of supports

Site measurements for the works shall be related to the system established for the setting out and measurement of the construction works in accordance with BS 5964-1. A documented survey of a secondary net shall be provided and used as the reference system for setting out the steelwork. The coordinates of the secondary net given in this survey shall be accepted as true provided that they comply with the acceptance criteria given in BS 5064-1. The reference temperature for setting out and measuring the steelwork shall be stated in the project specification.

Inspection of erected structure

The condition of the erected structure shall be inspected immediately prior to handover for any indication that components have been distorted or overstressed, and to ensure that any temporary attachments have either been removed satisfactorily or are in accordance with the project specification. If corrections are necessary they shall use methods that are in accordance with this standard.

Survey methods and accuracy

A survey of the position of the completed steel structure shall always be taken. This survey shall be related to the secondary net. Methods and instruments used shall be selected from those listed in BS 7307-1 and 2. The selection shall take into account the capability of the survey process in terms of accuracy relative to the acceptance criteria. If appropriate, the survey shall be corrected for the effects of temperature, and the accuracy of the measurements (relative to that in the reference system for the site surveys) shall be estimated according to the relevant parts of BS 7334. [Note: In most cases where surveys take place in ambient temperatures between 5°C and 15°C no correction is necessary.]

System of measurement

The system of permitted deviations is built up from position points at base level, an envelope for column verticality and a series of intermediate and roof levels referred to as as-built floor levels. Each individual value shall be in accordance with the values derived from the figures and tables. The sum of the discrete values shall not be greater than the permitted deviations for the total structure. The system sets out requirements for connection positions. Between these positions the fabrication tolerances define permitted deviations. The system does not set out explicit requirements for secondary structural members such as side posts and purlins. The requirements for these may be inferred from the fabrication tolerances of the member itself and the fabrication and erection tolerances of the members to which they are connected.

Reference points and levels

Erection tolerances shall normally be defined relative to the following reference points on each member:

- For members within 10° of the vertical – the actual centre of the member at each end;
- For members within 45° of the horizontal (including the tops of lattice trusses) – the actual centre of the top surface at each end;
- For internal members in built-up lattice girders and trusses – the actual centre of the member at each end;
- For other members – the erection drawings shall indicate the reference points which shall generally be the top or outside surfaces of members mainly subject to bending and centre lines of members mainly subject to direct compression or tension.

Alternative reference points may be substituted for ease of reference, provided that they have similar effect to those defined above.

Location, frequency and timing

Measurements will only be taken of the position of components adjacent to Site interconnection nodes as set out below, unless otherwise stated in the project specification. The location and frequency of measurements shall be stated in the inspection and test plan. [Note: The project specification should identify any critical dimensional checks of the as-built structure necessary in relation to special tolerances and these should be incorporated into the inspection and test plan.]

The positional accuracy of the erected steelwork should be measured under self-weight of steelwork only unless stated otherwise in the project specification, which shall then define the conditions under which the measurements shall take place. [Note: The project specification shall define the deviations and movements due to imposed loads, other than those due to self-weight of steelwork, where these can affect dimensional checks.]

Acceptance criteria and definition of nonconformities

Assessment of whether a nonconformity exists shall take into account the inevitable variability in methods of measurement calculated in accordance with the accuracy of the survey methods being used. [Note: BS 6954-1 to 3 give guidance on tolerances for buildings and the implications of variabilities (including manufacturing, setting-out and erection deviations) on the fit between components.]

Accuracy of construction shall be interpreted in relation to the expected deflections, cambers, presets and elastic movements of components. [Note: If significant movement of a structure is anticipated that could affect dimensional checking (eg for tension structures) the project specification should define an envelope of allowable positions.]

2 Planning for Erection

2.1 Sequence

Chapter 20 includes a section that identifies the design decisions that affect how the erection method statement is developed. In the broader design and planning context, there are three planning factors that affect the buildability of the scheme. These are:

- Practical erection sequence. The location of bracing or other means of maintaining structural equilibrium are crucial here.
- Simplicity of assembly. Simply-assembled connections are the main factors here.
- Logical trade sequences. This will affect how development of the master contract programme as the Pre-tender H&S plan metamorphoses into the Construction H&S Plan.



Choosing simply-assembled connections will affect the ability to use site welding. For a joint to be site-welded in position, the members will need to be held securely in position such that the fit-up for welding is accurate and rigid. Nearly always this will require both a temporary bolted connection and additional temporary supports. The need to provide these additional facilities often results in site welding being an expensive option.

2.2 Design

Four design factors contribute to buildability:

- Repetition and standardisation. There are two aspects to standardisation: repetition of the same building type (eg the portal shed) and common/standard details for connections.
- Achievable tolerances. If "tight" tolerances are specified (ie more restrictive than those in the NSSS), then special controls will be needed and possibly specially-engineered details.
- Frame type. Here, the primary choice is between braced or sway frames.

- Floor systems. For multi-storey frames, the choice of floor system will affect the erection sequence as it determines the stability of the part erected structure.



2.3 Site Practice

The key parameter when planning for erection is the piece-count. Figures quoted in the SCI case study on Senator House are an average 39 pieces lifted and placed per hook per shift and a peak of 60. With a single hook in use and piece weights averaging around 500 kg, this results in an erection rate of around 100 tonnes per week which releases over 1200 sq m of deck per week. This is a relatively heavy piece weight for a medium rise structure, but the area target is dependent on piece count not weight.

The number of pieces erected is dependent on the choice of crane. Cranes vary in their rapidity of movement (hook travel, slewing and jibbing out), and their overall productivity can also be influenced by a wise choice of location within the site footprint. If two crane lifts are necessary the rules for their use in tandem impose a significant penalty in terms of time taken to sling, lift and place loads.

Rates of erection are also influenced by whether special rigging methods and devices can be used for slinging and release of loads.



3 Interfaces

3.1 Structural Interfaces

The primary structural interface affecting steel erection is how the frame is to be connected to its supports. UK practice is generally to use holding-down bolts that are cast-in-place with some scope for lateral adjustment. Cast-in-place bolts have the advantage that they can contribute to the stability to the steel superstructure immediately – subject to suitable packing and wedging (see BS 5531). The problem with casting in bolts without adjustment is principally one for the foundation contractor and not the steel erector.

Using post-drilled fixings requires that the equilibrium of the structure be temporarily secured using, say, guys. This is rarely economic for primary members of the frame but is often used for secondary members such as wind posts for glazing. These can be offered up after the main frame is securely aligned and held in position using the main frame whilst their base fixings are drilled.

The same considerations apply where the steel frame has to be fixed to a concrete core or a masonry wall. Ideally, an adjustable steel attachment plate should be cast into the wall, then surveyed and adjusted such that the subsequent process involves merely as steel-to-steel erection.

In composite construction, the metal deck may need to be assessed for its ability to stabilise the steel members to which it attaches in the temporary condition before the concrete is placed and cured. The "wet concrete" stage is often when the decking is "working hard" to provide support for the dead load which is quite high.

Similarly with precast concrete floor/roof planks, often the most critical conditions arise during the placing of the units. Attention needs to be given to ensure that the asymmetric loading conditions that can arise are carefully controlled.

Finally, primary frame members such as portal rafters may rely on secondary elements such as purlins, ties and knee braces for their stability – even under self-weight only. Occasionally these secondary elements may be timber. In all such cases it is necessary that the erectors have a clear understanding about how many secondary members need to be in place (and how securely they need to be connected) before the crane lifting the primary frame member is released.



3.2 Non-Structural Interfaces

Non-structural interfaces that are common in steel-framed buildings include:

- Attachment points and penetrations for M&E services.
- Lift installations.
- Internal fit-out panels including fire protection boards.
- Perimeter and internal masonry walls.
- Metal cladding panels to roof and walls.
- Curtain walling.
- Glazing for façades and skylights.

The most frequent source of difficulty during erection is associated with the fit-up between the erected steelwork and components that require

tight tolerances. Common cases are lift installations, "high tech" wall cladding panels and façade glazing. The following explanation of how this issue should be tackled is based on a fuller example given in the Grey Book Commentary to the NSSS.

The NSSS tolerances are determined by what is economic within the process capability of the industry and what is necessary for reasons of structural stability. To determine what particular adjustments or clearances might be needed at a support interface between the steel frame and a close-fitting component, an estimate is needed of the variability of the support position offered by the erected steel frame.

A separate estimate of variability will be needed based on the details of the supported component and its associated dimensional tolerances. BS 6954 gives guidance on how these figures may be compared and BS 7307 explains how the necessary clearances and adjustments may be estimated. Typically it will be concluded that the supporting cleats need to incorporate adjustability at the attachment interface point.

In some cases there may be architectural or engineering reasons why the range of adjustment might need to be limited. There might be aesthetic restrictions or, in extreme cases, the additional eccentricity of loading could be critical. Perhaps the gaskets between components can only accommodate a limited amount of adjustment. In such cases, working the calculation 'in reverse' it is possible to deduce what restrictions might be placed on the permitted deviations for the erected steelwork beyond that given in the NSSS – but there would be costs associated with these reductions in tolerance.

For heavy cladding panels and masonry walls, the contribution of deflection under load is often a significant issue. Pre-cambering can be used to compensate for predicted deflection under dead load, but estimates of deflection are not generally exact. The danger might then be to plan the necessary restrictions as described above but to

ignore any uncertainty in the estimate of deflection. Assuming the deflection calculation to be fully accurate could then lead to the discovery of this contribution to overall variability only after erection on site, with consequent disruption whilst the solution was sorted out.



CHAPTER 15

Specification & Quality

By Roger Pope, BCSA Technical Consultant

1 Introduction

1.1 Specification

The purpose of specification is to precisely state how work should be executed to ensure that the erected steelwork meets the designer's assumptions and the client's needs. Most commonly the designer is concerned to specify requirements in a way that ensures that the structure is sound in the ultimate limit state. The client's needs may often focus on aspects of serviceability such as fit-up to other elements of construction or ease of subsequent maintenance.

Errors of specification can be expensive – either because corrections are later needed, or because over-specification adds unnecessarily to initial costs. For this reason, the industry provides national specifications for use as practical and economic benchmarks.

1.2 Quality

Quality in its broadest sense is a measure of an attribute such as strength, length or colour. Benchmarks are needed to be able to assess or measure quality, and specifications establish these benchmarks. Checking whether a product meets the specified benchmark for, say, strength is "quality control" [QC]. In addition, it is necessary that the whole management system should support the production of sound products – ie it provides "quality assurance" [QA]. An example that may help to distinguish QA from QC is as follows:

- A steelwork contractor receives an order enclosing a specification and drawings. The contractor undertakes an initial review of this documentation to assess whether what is specified meets what was offered in the tender, and whether the specification and drawings are consistent with each other and with what his own processes are capable of producing. This "specification review" is a key aspect of QA. It should result in a project-specific quality plan that identifies how the contractor's general quality management procedures need to be mobilised on this particular contract.
- Later, during fabrication, the inspection plan for the project requires that particular butt welds need to be tested ultrasonically to ensure that they are free from buried defects larger than those permitted. This is QC.

As illustrated, "quality" of construction can also refer to the design qualities that can be achieved with steel framing.

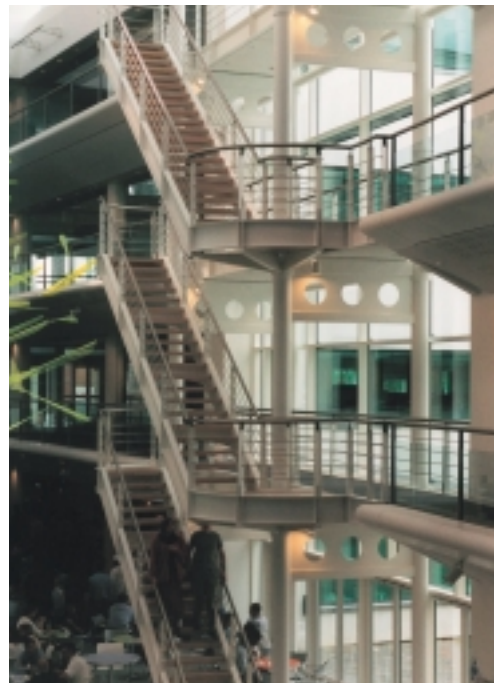

1.3 QA/QC and Quality Management

The "quality" standards are numbered in the "ISO 9000" series. The 1994 editions were as follows:

- BS EN ISO 9001: 1994 Quality systems. Model for quality assurance in design, development, production installation and servicing.
- BS EN ISO 9002: 1994 Quality systems. Model for quality assurance in production installation and servicing.
- BS EN ISO 9003: 1994 Quality systems. Model for quality assurance in final inspection and test.

Thus manufacturers without design or development functions could utilise ISO 9002, and those only concerned with checking output (QC in its narrowest sense) could use ISO 9003.

More recently, the term QA used in BS EN ISO: 1994 has become generalised to "quality management", and the requirements for such systems are now set out in generic form in BS EN ISO 9001: 2000 which gives requirements for quality management systems. The 2000 edition combines the coverage of the three 1994 editions. There is

also a series of other "ISO 9000" standards that supports the understanding and implementation of ISO 9001.

As ISO 9001 may be used in any industry from steelwork to banking, the schedules needed to support its implementation vary considerably. The Steel Construction Certification Scheme [SCCS] (previously the SCQAS) has developed a specific series of schedules for steelwork contracting.

Those who rely on firms having a certified quality system also need to be aware that the certifying authority issues a scope of certification. For instance, this scope may include design as well as manufacture (the ISO 9001/9002: 1994 distinction) or it may cover only supply of components (such as purlins) as distinct from the execution of whole steel building frames.

1.4 Origins of Non-Conformities

Non-conformities and non-conformance are terms used to describe products or situations which deviate from the specified practice beyond acceptable limits. For products this might be dimensional variations found during QC checks that exceed specified permitted deviations. For the system itself it might be a QA failure such as undertaking a routine check too soon after welding to identify cold cracking, or deviating from procedures in the quality manual – eg omitting to undertake the specification review at the commencement of each new contract.

An important aspect of any quality management system is that periodic audits are undertaken to establish whether there are systematic or common causes of non-conformities/conformance. The interrogation may discover unexpected causes from quite remote sources. For example, poor fit-up on site may stem from design decisions that do not anticipate foundation settlement during the construction period.

Later in this chapter, the section entitled "Problems in Practice" includes a review of the whole process from initial planning through to change of use in a way that is intended to highlight the possible origins of problems with "quality" of steel construction in the most general sense.

2 Correct Specification

2.1 National Specifications

Considerable effort over several years has been spent by the industry in developing the National Structural Steelwork Specification for Building Construction [NSSS] which is now in its 4th Edition. Accompanying the NSSS, the BCSA also publishes a Commentary – the "Grey Book". The NSSS invokes the necessary

supporting standards, such as BS 5950-2 for execution and BS EN 1011 for welding.

British Standards [BSs] are being gradually superseded by European Standards [ENs] which are issued in the UK numbered as British Standards [BS ENs]. For example, in the next couple of years, BS 5950-2 for the execution of steel building structures will be superseded by EN 1090-2 with an extended range of application.

2.2 The Project Specification

Each project generally requires its own project specification. In the simplest terms this might be an engineer's drawing with the specification written merely as notes on the drawing. On more complex projects it is common that a project specification is issued as a separate contract document. It often follows the National Building Specification [NBS] in layout and should be based on the NSSS as far as steelwork is concerned. As explained in the Grey Book Commentary, the NSSS allows for supplementary project-specific requirements to be added.

Many particular issues may need to be addressed in the project specification, and Annex C of ENV 1090-1 (the "prestandard" draft European Standard that will supersede BS 5950-2) includes a comprehensive list of these. A similar list is included in the Tables 1.1 to 1.7 of the NSSS (see chapter 16 for more explanation).

3 Quality Management

3.1 Steel Construction

As noted above, QA focuses on items that are of a procedural nature, and it is important to realise that poor QA can cause a construction failure as readily as poor QC.

There are five key elements described below that contribute to the satisfactory quality management of steel construction. The first two may be seen as QA procedures, the other three as QC.

Whilst other checks and procedures may be necessary to support these five elements (eg dimensional control of fabrication is a necessary precursor to a satisfactory erection handover), the elements are as follows:

(i) Information Exchange

Instructions are issued to the works in the form of fabrication drawings and associated electronic data. These instructions must correspond exactly with the specified intentions of the designers, and this can only be managed if all information exchanges and requests are recorded and controlled (see chapter 16).



(ii) Piece-Part Management

A piece-part management system provides the necessary traceability that enables checks to be made that the correct component has been erected, and that it is made from the correct steel sections and fittings.

(iii) Welding QC

Sound welding is crucial to the performance of welded joints. However, welding is defined as a "special process" whereby it may not be possible to verify that a weldment is satisfactory at final inspection stage. In-process checks may be necessary, and a welding plan should be available to identify when these need to be undertaken (see chapter 9 for further information).

(iv) Treatment QC

The timely inspection of treatment is important because it is generally very expensive to remedy later and some latent defects may take a long time to become evident. It is recommended that a treatment plan be prepared for each project that brings together the manufacturer's instructions for the products to be applied, the applicator's procedures and the specified requirements.

(v) Erection Handover

It is at erection handover that the work of the steelwork contractor is formally offered for acceptance. Generally the most important criterion at this stage is the dimensional accuracy of the erected steelwork. Although often referred to as "tolerances", acceptable limits are properly termed "permitted deviations". Appendix A to the "Grey Book" covers "Tolerances in Steel Construction" in depth, and includes a description of how site surveys should be undertaken, and the effect of cumulative tolerances. As illustrated, achieving good fit-up on site starts at detailing stage.



3.2 Quality Plans

Three key questions should be addressed when considering the implementation of a project quality plan:

- (i) Are there any checks or controls included in the project quality plan that are different from the

constructor's standard quality procedures? If not, is this project really that "normal"? If so, are these the only novel features, and has enough attention been paid to these novel features?

- (ii) What scope exists for using models, mock-ups, samples, trials or examples from experience on previous projects to prove in advance that anticipated performance can be achieved? As illustrated below, models can now include 3D virtual models.
- (iii) Does the project quality plan include an inspection and test plan, and is this consistent with the conclusions of the specification review and interface reviews (see below) relevant to that construction trade?

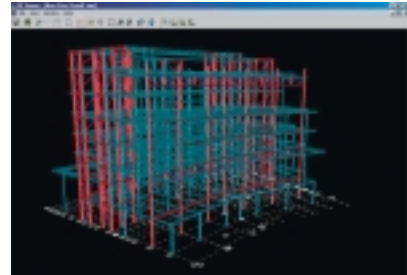

In steel construction it is common for the contractor to complete the design started by the structural engineer, and misunderstandings can occur about both design and specification. For this reason, the finalisation of the quality plan is promoted by an early dialogue between the parties to coordinate in the following three ways:

- (i) A joint design review involving both parties where design responsibility is split. This will allow both parties to exchange ideas about the basis and the development of the design, and its impact on the project specification.
- (ii) A specification review involving specifier and constructor that formally addresses the question "How is what has been specified going to be achieved?". One major item to be reviewed would be the specified requirements for permitted deviations (ie tolerances).
- (iii) An interface review involving constructors either side of an interface meeting to discuss the practicalities of the handover. As illustrated below, what criteria are important in ensuring a good fit between glass balusters the supporting steel frame?

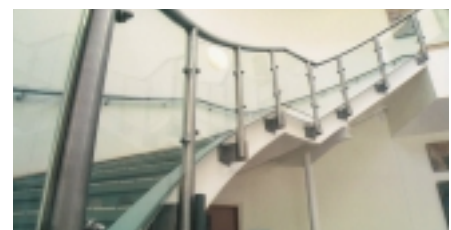

3.3 Declaration of Conformity

Under the Construction Products Directive, manufacturers of steel products, structural components, welding consumables and structural fasteners will all have to declare that their manufactured products comply with the relevant technical standard (which will be harmonized throughout the European Union). In the case of steel components the standard will be EN 1090-1 and the supporting technical requirements will be invoked using EN 1090-2.

A manufacturer's declaration will be needed for the fabricated components and does not relate to the erection process at all. For bespoke components pre-specified for a particular project this may have little added value, but it is easily understood that CE-marking of a "catalogue product" such as a proprietary purlin does provide comfort for the specifier. If false declarations are discovered it also allows action to be taken by national authorities outside of any contractual arrangements.

As steel components are "safety-critical", declarations by their manufacturers must be supported by third party certification of their factory production control systems. Although an assessment against the requirements of EN ISO 9001: 2000 is not mandatory, it is likely that many manufacturers will rely on their "ISO 9000" certification, provided it has a suitable scope of certification.

4 Problems in Practice

4.1 Defects

It is important to bear in mind that perfection is not an achievable ideal. Some degree of imperfection or permissible deviation must always be tolerated and suitable allowances made in design. It is not deviations from the nominal ideal but **excessive** deviations that can generate defects. Defects do not always lead to failure, but can do so – and sometimes with catastrophic consequences. The aim must be to design for fail-safe construction or construction that is robust against relatively minor defects.

A latent defect can become evident by directly causing failure, with local or perhaps catastrophic collapse ensuing without warning, or by initially causing distress without structural failure. Clearly the latter type of behaviour is to be preferred, and in most cases the inherent ductility of steel is of great value. Care is needed, therefore, to avoid brittle behaviour, where ductility is lost.

4.2 Experience of Failures

Based on a BRE/CIRIA survey of building failures (see references for this chapter) it has been concluded that:

- Faulty design was twice as likely to cause failure than faulty execution, with misconception of the load conditions and structural behaviour being most critical.
- The majority of failures occurred within four years of building completion, with few occurring after twenty years. Presumably many more are corrected during building construction. For instance, erectors are often the ones to notice lack of stability or robustness when a structure proves difficult to plumb.
- Use of experienced personnel and checking of design concepts were seen as the primary insurances against failure. For instance, checks of design concepts (as distinct from checks of calculations) can often be successfully conducted on a peer review basis by asking "what if?" type questions.

4.3 Checklist

It is often said the "one learns the hard way" in that experience of difficulties can be used to avoid such problems occurring again. Based on wide experience, the table that follows serves as a checklist of items that, if unattended, could lead to problems with the construction quality of steel-framed buildings. Time taken to check past practice used in comparable structures is often time well spent. In addition to peer review amongst designers, all those involved in steel construction can "interrogate" a wider database in that building structures are large and easily visible all around us.

DESIGN**Planning and control of design work**

Chain of responsibility	Without a sound basis for the chain of design responsibility the most likely defects are those of omission, such as assuming that a member shown indicatively on an architect's drawing had been properly selected and sized for its structural purpose. Use of the RIBA Plan of Work can establish who should do what, such as clearance of Building Regulations or obtaining waivers.
Programme for design work	Design work spans every decision affecting selection of materials and specification of work to be executed, and the person responsible for overall coordination of design should be identified and given continuous authority throughout the work. Without a sound procedural basis the most likely defects are those of omission, or mistakes due to role overload.
Information required schedule, and change control	Lack of discipline in exchanging information, especially about changes and modifications, can readily lead to mismatching decisions. The incidence of continual modifications and revisions is often a pointer towards potential defects. For instance, alteration of the treatment specification can easily be neglected when members are moved from one side of a sheeting line to the other.
Checking of calculations for gross errors, and reliance on computer-based design	Gross errors, and computer-aided howlers, are most likely to occur during structural analysis. Misconceptions about the behaviour of the structure can occur, causing long term problems if the problem does not become evident during erection. Mistaken sizing is more likely to be detected during the detailing process, if undertaken by experienced personnel.

Scope and split of design responsibilities

Match between sub and superstructures	It is common for these two responsibilities to be split between designers in different firms. Critical load cases and gamma factors used can differ. This can lead, for example, to forgetting to allow for uplift which is critical in maintaining stability against overturning in tall structures and hangars.
Strength and stiffness	Where load paths pass through different materials there is always likely to be difficulty in simultaneously matching strengths and stiffnesses. The action of masonry shear walls as bracing diaphragms (whether intended or not) can give rise to cases of local crushing of the brickwork or failure of a steel bolt group. Steel frames are also relatively flexible compared to other building materials. For instance, the cumulative lateral drift on a high rise building can cause glazing to fracture or even fall out.
Accidental load cases	The likely sources of overload need to be identified. In industrial structures it is common for large moving objects, such as lorries, to damage or remove columns if such key elements are unshielded.

Concept

Stability against collapse	A frequent cause of flawed conceptual design is that of lack of provision for stability against collapse. Suitably strong and stiff system bracing or sway frames have to be provided in both lateral directions, and restraint against torsional collapse can be essential in asymmetric buildings. Distribution of these actions to the foundations must follow suitable load paths, with attention given to how load shedding would occur from one path to another under accidental load cases – to prevent disproportional collapse. For example, there is a code requirement for multi-storey columns to be tied.
Key elements	A frequent cause of collapse of steel structures is failure of columns or other key elements such as beams supporting columns. Often the failed element has been subject to overload, but key elements should always be sized with robustness in mind – particularly where alternative load paths are absent. Bracings are often critical to structural stability, particularly where a single brace is all that prevents the structure becoming a mechanism.

Slender members	Local failure is often caused by instability of slender members, such as beams or trusses in lateral or lateral-torsional buckling. A common cause is the omission or deterioration of the restraint bracing needed, such as occurs with corrosion of fasteners connecting a timber floor diaphragm.
Tension members	It is often the case that innovative use of tension members makes them key elements to local performance if not overall building integrity. As in the collapse of balconies at the Hyatt Regency hotel, alternative load paths can be difficult to provide for such members, and extra care is needed in concept and detailing to ensure adequate performance.
Susceptibility to minor errors in execution	Whilst steel is generally a robust and ductile material well able to "stand up for itself", some members and configurations are susceptible to relatively minor errors of execution or damage. The thinner or more slender the member the more likely this is to occur. For example, special care may be needed with large diameter thin-walled tubes, cold formed sections, and tie bars or cables which can easily become kinked.
Fire safety provisions	Some degree of structural failure during fire is inevitable, but it should not be disproportionate. Attention to preserving stability through the bracing system and key elements is needed, and to those other elements, such as restraints, that maintain the capacity of the key elements.
Design assumptions	
Reliance on previous experience	Previous experience is valuable provided it is valid. Reliance on an inappropriate example can be a short cut to disaster. For example, the "off-the-shelf" portal frame used in a cold store could result in brittle fracture of steel subjected to low temperatures.
Reliance on testing	It is tempting to believe that testing can precisely establish a fact. Often, however, the test does not completely model the ultimate application, or is not statistically significant. Particular care should be taken with single results, which may lack a "control sample" to establish their general validity.
Foundation movement	To the steelwork designer who is used to precision, soil mechanics can seem like a black art. Foundation movement, laterally or through settlement or heave, can severely strain the steel structure. Usually, however, this leads initially to noticeable distress and only to failure if corrective action is not taken.
Wind effects	The wind has not changed but CP3 has been superseded by BS 6399. The new code is a revised attempt to predict a complex natural phenomenon. Wind tunnel tests are models which cannot exactly scale all the aerodynamics. Whilst building structures rarely exhibit overall failure or collapse due to wind, localised damage of cladding and the attached structural members is much more common. It is often better to allow the safety valve of local failure rather than risk overall collapse.
Extensions	It is dangerous to assume that an existing structure can be extended without reconsideration of the original design. For instance, the extension could increase the loads being picked up by wind bracing in the original structure. Fixing to an existing member can change its behaviour by, say, introducing additional restraint. Furthermore, loads from the existing structure can be diverted inadvertently into the new extension.
Rain or snow	Unanticipated extreme conditions are a common cause of drainage problems, alongside inadequate maintenance of gutters and downpipes. The effect on the steel structure can vary from severe localised corrosion, to distortion or failure of members supporting a roof which has ponded. Even where the steel does not corrode, water penetration can critically weaken masonry that is acting as part of the bracing concept for a hybrid structure. Drifting of snow behind fascias is not uncommon, but this can also occur behind large signboards added after building completion.
Humidity	In addition to water penetration from outside the building envelope, the designer may neglect to allow for corrosion induced by internally generated moisture. For steel, this is particularly important where acids or salts are present. In such conditions rapid corrosion of even stainless steels can occur, for instance over swimming pools or pickling tanks.

Lightning	Lightning strikes are common, and although a steel frame may protect building occupants by providing a natural conduction path to ground, attention needs to be paid to proper use of conductors across connections and to ground.
Low temperature	Normally a ductile material, steel is subject to brittle fracture below a transition temperature. Assuming the wrong minimum ambient temperature can have severe effects, particularly for tension members that lack redundancy.
Thermal range	Large temperature changes cause inexorable strains to be imposed on the structure, which can pre-empt some 30% of a member's design capacity. Whilst clad buildings often cycle over a limited thermal range, problems can occur if they are left unoccupied – and hence unheated – for a period. Ratchetting can also occur due to thermal cycles. For instance, a structure can develop a progressive lateral drift as light bracings are cyclically strained by thermal action acting against the inertia of the swayed structure.
Vibration	Close to resonance, vibration can act to magnify stresses and cause local failure or more general collapse. Vortex shedding around ties and crowd induced movement, such as dancing and marching, have caused such failures.
Dynamic loads	Fatigue failures are among the most common causes of failures in steel structures. Some have been particularly serious. Fatigue due to prolonged environmentally-induced vibration is rare, but fatigue is much more commonly caused where dynamic loads are induced by mechanical equipment. Sometimes these are ignored by the designer, or equipment is installed later without thought. Occasionally the frequency of equipment usage increases significantly beyond the design case used, reducing the fatigue life critically. Additionally, special care can be needed where fretting occurs or corrosive conditions exist alongside cyclic actions.

Codes and standards

Code usage	Design codes are carefully drafted, and usually conservative, attempts to provide a safe procedure for design. By their nature, the procedures are selective, and not all conceivable cases are covered. Blind application of the code rules, without understanding of the underlying physical principles, can lead to inappropriate solutions – in tall slender structures for example. Also loading codes are only guides, albeit authoritative ones. Cases occur of exceptional loading which is sometimes unexpected – for instance store rooms, safes or battery rooms.
Load cases & gamma factors	The portfolio of load cases selected for design analysis, and the gamma factors used in weighting of combinations, can sometimes omit key cases – such as uplift on the roof. Clarity in the brief, combined with a "three-dimensional" understanding of the structure should prevent this.

SPECIFICATION

General

Basis of specification	The specification exists to translate the designer's requirements into specific work instructions for execution. BS 5950-2, the NSSS and more recently ENV 1090 all exist to clarify and aid this process. Specifications that lack accuracy, precision or well-founded rationale can result in ill-conditioned structures with unintended and unnoticed defects, that sometimes lead to failure.
Design life for treatment	BS EN ISO 12944 (which supersedes BS 5493) provides a framework for selecting a treatment specification suited to a chosen design life. Most structures are used well beyond the design life initially envisaged, and deterioration due to corrosion can sometimes then accelerate quite suddenly.

Material selection

Steel grades and subgrades	The European Standards for steel products define a wide range of materials. Some are unsuited to welding, possessing carbon equivalent values that are too high; some are unsuited for use externally, possessing Charpy impact values that are too low. Wrongly specified material can cause failure – in, for example, thick tension members without adequate notch ductility.
----------------------------	--

Hydrogen control	Weldable steels need appropriate welding consumables. For example, cold cracking can occur in welds or the heat affected zone, especially in higher grade steels, if suitable control of residual hydrogen is neglected.
Special steels	Whilst the range of weldable structural steels is wide, the range of steel materials used in mechanical engineering is much wider. Some of these can serve as structural components, for example machined pins or high strength ties. Particular care is needed in specification, however, as they are unlikely to be weldable easily, if at all. Defects can be initiated by such simple details as tack-welding of nuts – a practice to be avoided as the result is likely to be excessive local hardness, combined with the limited ductility of the nut material.
Use of special materials or novel uses of more usual ones	Buildings last a long time, often much longer than originally planned, and a poor understanding of long term performance of materials in novel applications can result in failure. Degradation under ultra-violet radiation, creep and work hardening are all possible origins of long term failure in novel materials.
Manufacturer's instructions	Manufacturers of custom products are liable for the performance of those products, but only where they are used in accordance with the manufacturer's instructions. Any limitations, restrictions or installation procedures specified by the manufacturer must be observed, as early deterioration or failure can otherwise occur – such as with galvanized cold formed purlins used over a pickling tank.

Fasteners

Appropriate selection	As with steels, the range of structural fasteners is wide, and the range of mechanical fasteners used structurally much wider. Care in specification and observance of manufacturer's instructions is essential. This is particularly because many fasteners achieve high strengths at the expense of poor ductility, which can be critical in prying or where stress concentrations occur – such as where too few threads share the strain.
Fastener assemblies	A "pick and mix" approach to selection of items in fastener assemblies can result in mismatches such as interference or excessive clearance between nut and bolt leading to bolt shear in torsion due to binding during assembly or thread stripping during tightening or, more dangerously, later during service.
Appropriate treatment	Higher property class fasteners, like higher grade steels, are susceptible to hydrogen embrittlement. Pickling during galvanizing, and other acid based treatment processes, introduce hydrogen into the metal surface that must be driven off by stoving if failure is to be avoided.
Need for preloading and locking devices	Preloading of fastener assemblies is necessary in more applications than just that necessary to develop friction grip action between faying surfaces. Bolts used in tension under cyclic stresses are susceptible to failure due to local crack propagation, and nuts subject to vibration may work loose unless secured by some form of locking device. The use of preloading can improve the performance in both cases.

Welding procedure specifications

Fatigue	The requirement for written welding procedure specifications is standard for all structural welds. Previously, a common cause of failure in welded structures has been that of poor performance of welds – many seemingly unimportant but actually in critical locations such as those where fatigue effects were critical due to cycling, fretting, vibration or corrosion.
Lamellar tearing	Written welding procedure specifications also help to ensure that the requirements for the weld match those of the heat affected zone of the parent material. The incidence of lamellar tearing in thick material was a serious example of a previous problem in this regard, although there was very little risk of affected structures being allowed to enter service without repair. This risk is now much reduced, due also in part to improved casting and rolling techniques for producing steels with better grain structures and better chemistry.

Low temperature	A third example where written welding procedure specifications can help to avoid the use of inadequate techniques is for welds intended to perform in low temperatures. Mechanical test requirements can be specified, with the requirement being that weld, heat affected zone and parent metal are all demonstrated to possess adequate notch ductility under the Charpy test [or CTOD test] to avoid brittle fracture at low temperature.
-----------------	--

Treatment specification

Products and manufacturers	Defects from poorly written treatment specifications are common, albeit that serious structural failure from this cause is very rare. Problems often originate where manufacturers' advice is not sought, not followed, or misinterpreted. Except in maintenance applications, most manufacturers are unhappy with specifications where their products are applied over another manufacturer's products, as the chemistry of the intercoat adhesion is a key aspect of performance of the combined coating that is difficult to assess in those circumstances.
----------------------------	--

Matched repair procedure	All treatment systems require repair, and close attention to the practicality of the repair procedure specified can help to avoid defects from this source.
--------------------------	---

Life to first maintenance and the nature of maintenance	For prudent reasons, manufacturers and applicators are reluctant to warrant long lives to first maintenance, but many building owners leave products unmaintained for much longer than the specified period which can lead to defects and greatly increased work when the maintenance is finally undertaken.
---	--

DETAILING

Connection design

Match to principal structural design	In the process of producing working drawings, detailing entails making many design decisions, which must be related to the main design concept and analysis. The incidence of mismatches, some potentially serious, has resulted in the development of a clear brief for the exchange of information between principal structural designer and detailer. This information is listed in the NSSS. An example of a potentially serious defect from such a mismatch would be the unrestricted use of hard stamping introducing hard spots or cracks into critical zones such as plastic hinges.
--------------------------------------	--

Codes for detail design	Not all authoritative design practice is codified in British Standards, and industry standards can provide essential guidance. The extensive range of green books on tubular structures published by CIDECT are examples, and designers proceeding without seeking or heeding such advice are more likely to introduce defects.
-------------------------	---

Connection positions & types	Connection positions, including splices, are not always located at member ends. The choice of location and the type of detail may affect the way in which loads are distributed by the structure. Also, splices in compression members must be designed for local moments arising from initial imperfections that may exceed that assumed for the unspliced member, otherwise premature buckling may be induced.
------------------------------	--

Loads

Load paths	The paths by which loads are distributed through the structure to the stiff supports are largely determined by the relative stiffness of the various possible load paths. Problems can occur where significant eccentricities are introduced into the local load paths in connection zones, or where the path passes through different materials such as from precast floors or masonry walls acting as diaphragms into steel vertical bracing systems. Also, racking can occur in which the load passing through the fasteners into cladding or decking acting as diaphragms causes failure of the thin gauge sheet material locally.
------------	--

Foundations	At the foundation supports, there is often a division of detailing responsibility that can introduce errors about such matters as grouting, corrosion protection of holding down bolts and lightning conduction arrangements. The action of the foundation is critical to maintaining stability of the structure against overturning. Cases have occurred of steel structures falling over as complete entities where they have simply parted company with the foundations in uplift.
-------------	---

Anchorage for ties It is common for the capacity of a tie to be limited by the strength of its anchorage rather than that of the tie itself. If this is not appreciated, overload of the anchorage can occur, particularly as the lively nature of tension structures can mean that significant overload is picked up by some members during extreme conditions.

Following trades At the detailing stage, it is frequently the case that holes and attachments to suit the following trades are added to the steel members. Occasionally, these can have a critical influence on the performance of the steel member. An example would be the removal of a substantial portion of the web of a beam for service penetration.

Temperature effects

Expansion and contraction Where expansion joints are provided, the most likely cause of failure is from the build up of frictional forces. This can occur due to overtightening of bolts, corrosion of surfaces intended to slide or unintended local eccentricity – often where deflections cause misalignment, such as where side posts meet rafters. Similar problems can also occur with bearing details. For example, ratchetting induced by thermal cycling can pull beams off masonry seatings if the "stiction" in the bearing causes the beam to push the wall out of plumb.

Differential temperature effects It is not uncommon for cladding to reach high temperatures, and local temperature differentials can be quite large where conduction contact across the interface is poor and thermal inertias are large. The differential expansion induced can cause distress, especially to fasteners at the interface and to the local material through which those fasteners connect.

Corrosion

Sealed spaces Sealed hollow sections do not corrode internally as there is no supply of oxygen or water to sustain the process. However, incomplete seal welds, porosity in seal welds or penetration of tube wall by fasteners can introduce holes through which moisture and air can pass. Poor details for open sections, used externally or in humid environments, can also introduce water traps that increase local corrosion markedly.

Bimetallic interfaces Accelerated corrosion is common at bimetallic interfaces, and lack of attention to this effect at interfaces with stainless steel or, more importantly, with aluminium can result, for example, in early failure of sheeting fasteners.

EXECUTION

Organisational management

Capabilities The best security that designers can have that their design will be executed properly is to entrust the execution to an organisation with appropriate and proven capabilities. This can also largely eliminate the fear of sharp or corrupt practices. Those organisations need to employ competent people using proper management systems, and arrangements exist within the industry to provide independent assessment of organisations.

Quality assurance A management system certified as providing appropriate quality assurance will ensure that matters such as the sourcing of supplies and sublet design, fabrication and erection work is controlled. Without this, there is a significant risk of non-conforming work being incorporated into the structure. The use of safety factors in design often succeeds in preventing such defects from causing serious failure, leading to a false sense of security. For example, a general safety factor may be insufficient to ensure adequate capacity of particular key elements, such as butt welds in the tension flange of a beam supporting a column.

Project management procedures

Planning of work Inadequate planning resulting in unclear work instructions or short-cuts to overcome lack of time or resources can result in significant reductions in quality of materials or workmanship. It is now common for specifications to require formal plans to be prepared for the key elements of execution – welding, treatment and erection.

As-built records	The discipline of updating working drawings with as-built information as records helps to eliminate two sources of potential defects from misunderstanding. Firstly, the designer is likely to be made aware of inadvertent changes to the design – for instance, site welding may have been used to fix a beam resulting in a nominally pinned connection being made rigid. Secondly, the building owner is likely to be made aware of how the structure is constructed.
------------------	---

Content of project quality plan

Contract review	Perfection of execution is impossible, and hence a contracting organisation needs to be aware of the capability of the processes that are employed, such as the range of dimensional deviations arising from the fabrication. Lack of understanding of process capability, and inattention to comparing this to specified requirements such as permitted deviations (or tolerances) can result in uncorrectable defects.
Task allocation and clear work instructions	As with inadequate planning, allocation of tasks to individuals without the necessary competence or to competent individuals without the necessary authority can result in unnoticed or uncorrected defects being built in to the structure. Similarly, lack of clarity in work instructions can also build in defects – such as column splices that do not work in full contact bearing as intended.
Quality control	Quality cannot be inspected into a product, it needs to be rooted in proper quality control practices that check the proper functioning of the processes involved and include provision for action to be taken before products in general reach the minimum specified level. Without this, any sample testing of end product for acceptance will be at best haphazard – resulting in no confidence that the remaining unsampled end product does not contain significant numbers of non-conforming items.
Use of second or third party approvals or witnessing of inspections	A project quality plan normally deals with the aspects of quality control that are project-specific differences from the organisation's standard practice. The basis is that the organisation is responsible for operating systems that support its ability to warrant that manufactured product meets the specified requirements – that is a first party warranty. Occasionally the second party client wishes to institute another layer of control, either directly or through an independent third party inspection body. The layer of control can be a full check, agreed hold points with approvals to proceed, or mere witnessing of first party inspections or tests. Danger of defects can arise where the several parties are unclear as to who is checking and approving what. For instance, where mechanical tests are undertaken on macro-specimens taken from welding procedure trials, it could be that only those that pass are transmitted on to a third party, and the others are "recycled" until acceptable.

Material sourcing

Steel	The use of poor or substitute materials, for example thick plates with laminations or cracks or cold formed tubes used instead of tubes specified as hot finished, can result in critical latent defects. Occasionally, fabricators who are used to sourcing material that exceeds the specified minimum by some margin are supplied with barely-complying product. Unexpected problems with, say, welding can then occur. Traceability of material properties back to the producer is important, and only certain inspection documents (previously termed test certificates) provide sufficient details. Reliance on an established and competent producer, such as Corus, can help to prevent such difficulties arising. However, a clear understanding of the product standards for the material involved is still important. For instance, BS EN 10025 includes specification options concerning the process route for production that may be critical to ductility.
Fasteners	Fasteners need to be checked for conformity to the specification. There is a world market in fasteners, resulting in some products of dubious origin being in circulation. Unless the original producer is known with certainty to be reputable, any manufacturer's warranty is worthless. In such cases, testing of sample assemblies – by distributor or contractor – is advisable.

Fabrication

Mock ups and trials As most structures are unique, full type-testing to prove subsequent production is inapplicable. Careful selection of subassemblies for mock ups, trial assembly or trial erection can, however, be used to overcome potential problems, such as excessive lack-of-fit.

Local details Poor execution of local details in material preparation can be especially critical to performance – for instance, over-cutting of notches, over-sharp cutting of internal corners, thermal distortion or punched holes in overthick material. Irreversible damage to can be caused to steel materials by the uncontrolled application of heat – especially when material is held in the blue heat range of 250 to 380°C or where large residual stresses are left in the material. Also, local stress raisers can be introduced by temporary attachments, hard stamping, stray arcing or other hardened spots.

Welding

Fit-up prior to welding The progenitor of a good weld is good fit-up between the parts before welding. An excessive root gap leads to secondary stresses due to eccentric load paths through the weld, and can cause lack of fusion defects – especially in unbacked joints.

Control of welding There is little similarity between the relative ease of fillet welding thinner material using, say, the MAG process, and the complication of butt welding thick materials in higher grades. Without careful control of the necessary pre-heat, heat input, interpass temperatures and post-heat, serious defects or excessive repairs can arise. However, even with simpler requirements, lack of control of basic matters, such as using low grade filler material, electrodes not being dry or welding over paint/moisture, can cause subsequent failures.

Distortion High heat inputs during welding can result in distortion of the weldment due to differential restraint conditions during thermal expansion and subsequent contraction. Heat treatment of the completed weldment will relax any residual stresses, but may not succeed in resetting the weldment back to its intended shape.

Site welds Some welds are poorly executed because access to weld is difficult. This is more common on site, where items are often unalterably fixed in orientation thus dictating, say, the need to weld in the overhead position. Another difficulty with site welding is that the joints can be fixed in position with a very high degree of restraint. As all welds shrink during cooling, pull-out of plugs of parent material can occur - although this would rarely escape inspection to become a latent defect.

Cold cracks Cold cracks occur due to lack of control of residual hydrogen which diffuses in the cooling metal to a preferred location that then becomes the basis of the crack. Such defects can pass through undetected as the diffusion process can takes days to take effect.

Treatment

Shop Surface treatment of steel is a process that often produces defects, but, in contrast to welding, these are far less likely to result in serious structural failure. Lack of care in application can result in faulty paint formulation, poor surface preparation, deterioration of preparation or previous coats prior to overcoating, poor coating thickness control, or excessive humidity. The most common resulting difficulties are problems with intercoat adhesion, or early localised breakdown – for instance on sharp edges.

Site The two most common areas where defects occur during site painting on new steelwork with works-applied systems are with treatment of the fasteners and with site repairs. Satisfactory results rely on appropriate products being available to suit those applications.

Erection

Erection method statement	Without a clear and well-thought-out method statement, serious problems can occur during erection. The most critical aspect is control of overall stability against collapse. In very rare cases, erection can be completed apparently satisfactorily yet with serious incipient problems stemming from a "meta-stable" structure. For instance, a large dead load could be balanced on a beam that was not robust against lateral buckling that could be precipitated later. Also, the installation of bracings is a critical activity. On tall buildings, bracings in the lower storeys can be compressed as columns shorten, resulting in lateral bowing of the bracing which can damage adjacent walls as well as introducing a "dead band" into the response behaviour of the structure to lateral loads.
Ambient temperature	It is a common misconception amongst erectors that slotted holes detailed to act as expansion joints are also there to provide clearances to compensate for the cumulative effect of fabrication and erection tolerances. As a result, the expansion detail can be initially set up in the wrong part of its movement range, with later problems when a change of temperature attempts to strain the joint beyond the remaining clearance.
Supports	The steel erector is far more experienced in lifting and positioning heavy components than in grouting which involves cleaning out holes and filling them with a stiff semi-liquid that corrodes the hands and oozes out where it should not. However, although the result is that the spaces under base plates are sometimes incompletely filled with grout, this rarely leads to any failure. Similarly, holding down bolts are frequently cast almost immovably outside of the permitted positional tolerance. Although this can result in something of a force-fitting process, this also rarely cause failure.
Cumulative tolerances, and deflections expected and experienced	Some lack-of-fit is inevitable during erection as it is an assembly process that is the culmination of a series of manufacturing and surveying processes that introduce various induced deviations in dimensions. Furthermore, steel members are relatively slender and flexible such that their self-weight deflections can be quite significant, and sometimes damage can occur during handling. Nearly always such difficulties are evident during erection and are resolved then, with special attention needing to be paid to columns or struts that are bent or bowed beyond permitted limits. Attempts to force-fit bracings or burning through of bolt holes can be examples of possible symptoms of deeper difficulties. Rarely the structure is left with serious cumulative problems – such as a bolted triangular truss with a residual skew due to cumulative slip of bolts in clearance holes.
Survey	The erection drawings should make clear where nominal dimensions have been adjusted to allow for effects such as column shortening under load. Occasionally, structures can be erected neglecting such points with the result that an unintended pre-set is introduced.
Adjustments during alignment	The use of shims and packs to set columns to level and to adjust for deviations in beam lengths is standard practice. Occasionally, several packs are needed in one location, and these should be secured in position, by tack welds say, if in danger of coming loose. Rarely, the proper operation of a connection can be jeopardised by poor practice. For instance, to fill a tapered gap where full contact bearing is required, packs must be of suitably soft steel used in small increments.
Symptoms of problems	Experience during erection can often be used to prevent the incorporation of latent defects into the structure. For instance, where columns are difficult to plumb, where column splices do not seat properly, where bracings do not fit properly, or where hips require significant site remedial work – then a deeper problem may be present.
Fastener installation	Higher property class bolts are inherently less ductile than most structural steel, and they can be overstressed during tightening. For example, a bolt could be used to draw up a connection resulting in large prying forces being exerted on the bolt head. Also, fasteners can be omitted from groups or the wrong fastener can be inserted – particularly if bolts marks are confusing or missing.

CHAPTER 16

Information

By Phil Williams, BCSA

1 Introduction

Despite the fact that steelwork contractors have been using 3D-modelling systems for detailing and workshop process control for the past decade, and despite the many advances made in software packages to facilitate the integration of analysis, design and detailing, the issue of efficient 'information flow' remains an elusive goal.

At the interfaces between the various parties involved in a construction project, conflicting requirements and priorities are still evident, and inefficiencies (where either vital information is not provided or is provided later than needed) inevitably surface. This results in:

- Delay – whilst the information is belatedly prepared and made available, and/or
- Cost – where action to incorporate the stipulations of the late information is taken at an inappropriate and uneconomic later stage in the process.

So, whilst good progress continues to be made in software packages to allow information to be passed 'seamlessly' between the different packages employed by the parties to a project, it would appear that those same parties have little understanding of the 'total information' required by others, and the stages at which that information is required. Whilst this is true of construction as a whole, it is of particular significance to steelwork contracts, where the need for timely, complete and unchanging information is of paramount importance.

This chapter outlines the potential conflicting information development requirements relating specifically to steelwork, and the steelwork contractor's absolute need for complete information at a very early stage in the steelwork contract. It also includes pertinent extracts from a study carried out by BCSA in partnership with the Construction Industry Computing Association (CICA) investigating 'information exchange'. Finally, sections of the National Structural Steelwork Specification 4th Edition and the Commentary on the NSSS are discussed, illustrating that the information requirements of the steelwork contractor are set down in this specification in checklist format.

2 Conflicting Information Requirements within the Supply Chain

The distinction between the responsibility **to provide** information and the need **to receive** information related to a steelwork project illustrates the difficulty in achieving adequate and timely information flow between those parties.

For the **client**, the over-arching concerns are perceived to be cost and completion date, particularly for commercial office or retail projects. This emphasis on completion date permeates all other activity, resulting in pressure on all activities – conceptual development, design, fabrication and construction.

The **client** requires minimum time to completion – this translates into minimum construction period and, for example, minimum steelwork lead-time (contract award to first delivery to site) for the steelwork contractor. However, this primary demand can easily be in conflict with another of the client's desires for maximum 'scheme flexibility' for the longest possible period of time. This latter requirement leads to a postponement of irrevocable decision-making that is, by nature, crucial to those awaiting the decisions, and to the forced accommodation of significant change by others in the chain at a later, inappropriate and uneconomic stage in the project.

The project **architect** has the task of ascertaining then developing client requirements and of accommodating client changes and developmental changes across the broad spectrum of the entire project. Yet there are those whose tasks are no less demanding who are waiting for fixed and sufficient information to be passed to them to enable them to carry out their own responsibilities, still against the overall contract time pressure. As far as the structural frame is concerned, whilst late changes may be relatively easy to accommodate within the architect's responsibilities, they may cause considerable re-working for the project's **structural engineer/designers**, who have to invest considerable resource in detail design and the realisation of the client's and architect's vision.

At each stage, the abortive costs arising from incorrect, incomplete or delayed information increase exponentially as more human and tangible resource become involved. It is self-evident that once the scheme concept and design has transferred to the construction phase, the **principal contractor** and **subcontractors** have an almost unlimited potential to accumulate delay and cost if information flow becomes a problem.

Throughout the simple chain described above, there is an almost inescapable 'just-in-time' approach to information flow. Whilst this may be inevitable and not, of itself, necessarily totally undesirable, the evidence is that those providing the information on a just-in-time basis (because they have their own time and knowledge pressures upstream) do not have a sufficiently developed understanding of the needs of those receiving the

information (both in terms of its scope and content, and its 'timing'). The notion that delivery of supplies crucial to maintaining efficient process flow could be entirely separated from just-in-time manufacturing is nonsensical and would bring the process to its knees immediately. Yet, throughout a construction project, the points at which information flow breaks down are evident, as are the costs and inefficiencies that follow. These are exacerbated by indirect contractual relationships, where a subcontractor's need for complete information is only channelled through a third party with no direct need to use the information.

3 The Steelwork Contractor's Specific Needs

Over a little more than a decade, the activity and methods employed within a steelwork contractor's workshops have changed beyond recognition; integrated modelling, process control and management system software have provided the impetus and the tools to change steelwork fabrication into an off-site manufacturing process. The success of this is undeniable, and is evident in stark economic terms – fabricated and erected steelwork has the **same price per tonne** as in 1990, despite the fact that the raw material and manpower costs have increased in line or in excess of inflation. The added value of 'fabrication' within the works is now a fraction of the cost of fifteen years ago.

This has been achieved through numerical control of major processes within the workshops, as exemplified by the saw-drill lines now prevalent across the sector. These 'automatic' machines allow very few people to produce the majority of throughput in the workshops, with flow-line layouts and machines capable of drilling on multiple axes. Small 'parts' (end plates, stiffeners etc) are produced on NC punches or plasma machines with exceptional efficiency.

The software that enables this progress has developed to a fully integrated suite, such that an entire 3D-model of the structural steelwork and all secondary steelwork can be built within a few days of confirmation of the contract and receipt of scheme drawings. This model is then used as the integrated driver of the NC machines in the workshop, the ordering of steel, bolts, consumables etc, and the project planning and site erection planning.

Within the context of receiving 'incomplete information flow', however, its very strengths become frustrations. The efficiency of the entire system is adversely affected if the information is not complete at the time the 3D-model is constructed or within a very limited period. Traditionally, completion of design followed the construction process – foundations first, columns next through to secondary steelwork, door and window framing, cladding support etc last. Whilst clearly the entire supply chain has moved to sophisticated computer modelling, two problems remain; these are:

- Incompatibility of software packages within the supply chain, and
- A lack of comprehension of others' needs for information.

Incompatibility of software packages, the inability to pass a model from one stage of the process to the next, has been with us for a very long time, and this issue is explored in chapter 17. Massive strides have been made in this area (along with massive expenditure), and visions of complete, holistic models beckon to us; it is interesting to note, however, that even experts in this field have expressed within this publication, their doubts about a speedy solution to the generation of complete project models.

Arguably, the second issue is the more important and the more depressing – we appear not to move forward in appreciating each other's needs for information, nor do we champion realistic or changed working practices that would allow those information needs to be met.

This is most graphically expressed in the statement that the steelwork contractor needs **all** of the information to allow him to construct his complete steelwork project model within 2-3 weeks of contract award. All secondary steelwork etc has to be decided, designed and detailed, such that all the holes in a beam or column, for example, are accounted for (both primary and secondary connections, and holes for attachment of running lines, manlocks etc to permit safe erection). Steel will be ordered within two weeks of contract award, and fabrication could start as early as weeks 4-5 of the subcontract.

It is unnecessary to point out that an extra hole to be drilled in a column or beam after it is erected and in place will cost, say, 100 times more than if that hole had been drilled automatically in relatively few seconds on the saw-drill line.

The parallel change is that over the last ten years, the proportion of steelwork procured in the UK by the design-and-build route has risen rapidly to more than 50%. The ability of the contractor to manage the information flow in the D&B context is very different. One further particular area where information critical to the steelwork contractor's responsibilities is often a cause of upset, delay and cost is in the specification of loads for the design of connections. Where the steelwork contractor is working on a design and build contract, this hiatus is usually avoided, because he is aware of his own needs and timing. However, in contracts where the structural engineer is responsible for passing over information on the loads to be resisted by connections, for the steelwork contractor to carry out the detailed design of the connections, such information is needed immediately after contract award, so that the connection designs can be completed in good time to be incorporated into the 3D-model.

Such is the change in steelwork contractor's requirement for information.

4 'Efficient Steelwork Procurement through Improved Information Exchange'

Efficient Steelwork Procurement Through Improved Information Exchange was the title given to a project, part-funded by the Department of the Environment, Transport and the Regions, which focused on the crucial exchange of design information at the key stages of tender invitation and award, through to the fabrication of structural steelwork. The critical aspects of the work, described below, were carried out early in 2000, and the report from which the following paragraphs are taken was completed in September 2000. Although three years have passed since the completion of the project, most of the findings are as valid now as they were then; there has been remarkably little improvement in those areas that were of concern in 2000. Despite the 'negatives', there were some very strong 'positives', and the need to build upon these remains.

The project was set against a background of the established use of IT in the industry and a growing realisation of the potential benefits of Electronic Data Interchange (EDI). The work sought to survey and record the use of IT and EDI, the perceived and actual barriers to greater use of EDI and to forecast the potential benefits that could be obtained through its more widespread adoption.

The work was carried out by the British Constructional Steelwork Association (BCSA) and the Construction Industry Computing Association (CICA), with assistance from the Association of Consulting Engineers (ACE). The project's main "interaction" with industry was through a questionnaire; from an early stage it was recognised that, although many questions were relevant both to Consulting Engineer and Steelwork Contractor alike, there were sufficient differences to warrant two questionnaires. By the due cut-off date, in excess of 100 replies had been received.

The survey found the use of IT well established within individual organisations. EDI, while by no means universal, was nonetheless a regular event for most respondents. A majority of respondents found the information useful or very useful and at least the same if not better than its conventional paper form.

However, there were adverse comments on the quality, adequacy and timeliness of information received by the steelwork contractor, whether that information was in digital form or more traditionally on paper. A better understanding of the steelwork contractors' information requirements emerged as the biggest single requirement.

4.1 Responses from Consulting Engineers

(i) Current transfer of information in digital form

Digital information is both asked for and offered but not always provided or accepted.

Have you been asked for information in digital form?

84% - YES	16% - NO
-----------	----------

When YES, the information typically provided was drawings in Autocad format on disk or by email.

(ii) Digital information to the Steelwork Contractor

Is information ever offered to the fabrication in digital form?

44% - YES	56% - NO
-----------	----------

The information offered was usually drawing files in Autocad format.

If YES give percentage of jobs in last twelve months:

The responses ranged from 0% to 100% with the majority falling in the 20% or less range.

If NO why not?

General response is that this has not been requested yet. Also "small steelwork contractors / big blacksmiths don't have the facilities."

"Because it would require additional work to remove out of date data and correcting information in digital form which is not visible on paper. Requires a degree of checking which is not economically viable."

(iii) Obstacles to providing information in digital form

What do you see as the major obstacles to consultants providing information in digital form to the steelwork contractors?

The responses can be grouped under the following main headings:

• Compatibility of systems:

"Steelwork contractors need to have software which supports Autocad and be capable of receiving information in digital form."

• Cost and time were seen to be factors:

"Cost of preparing disks – or emails, zipping files etc when often a paper copy is also requested. The principal component of this extra cost is time."

"More work for the consultants if they have to produce the 3D-models that are required to export directly to Strucad etc."

• Concern about revisions:

"How revisions are managed. Is the accuracy compatible? Is the volume of data too great to handle? How is the intent of design conveyed electronically?"

"Keeping up with changes to GA's."

• Some did not see a problem:

"None at all. We are constantly sending all information to all parties via email."

"Not aware of major obstacles."

4.2 Responses from Steelwork Contractors

(i) Quality and adequacy of information received

Stage	Good	Adequate	Inadequate	Bad
Tender	10-20%	40%	20-40%	15%
Award	15%	35%	40%	20%
Design Development	25%	40%	25%	30%

Timeliness of information received

Stage	In Good Time	Just in Time	Late	Too Late
Tender	30%	40%	25%	15%
Award	25%	45%	35%	15%
Design Development	25%	40%	30%	25%

(ii) Information provided in digital form

Almost 80% of the respondents received information in digital form. On average this accounted for 20% of jobs in the last 12 months.

Respondents were asked to predict what this would be in 12 months, 3 years and 5 years. The average predictions were:



21% "Very Useful"	68% of respondents found digital information "Useful"	11% "Not Useful"
-------------------	---	------------------

50% used the information at Tender Stage
56% at Award Stage
94% at Design Stage

(iii) Comparison between digital information and conventional paper

44% found digital information better than conventional paper	39% found it the same	17% worse than paper
--	-----------------------	----------------------

The reasons given for these assessments included the following:

• Of those answering "Better than"

Speed: All (assessments listed) but time mainly.

"Can be used directly in 3D drawing systems, ie saves time and more accurate."

• Of those answering "Same"

"Learning curve still to be overcome."

"Good quality but generally incomplete."

"Never complete, never accurate."

• Of those answering "Worse"

"Digital information is often incomplete and inaccurate after it has been moved from one computer to another."

"It is not possible to prove that the information received matches the information that the sender sent (or intended to send)."

(iv) Impact of better more timely information on out-turn costs and lead times.

Respondents were asked to draw from their own experience to predict likely savings and lead time reductions.

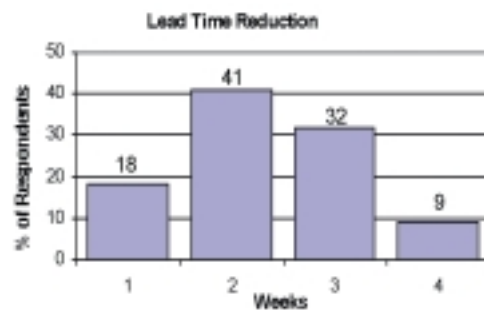

(v) Improvements in information flows that could improve profit/out-turn costs

Respondents were asked to give three key improvements; the answers can be grouped under four main headings:

• Early liaison / approval:

"Early liaison between engineers and architects so drawings compare from tender stage."

"Full design loads, dimensions, levels etc, available from day one."

"Design philosophy at tender stage."

"Approval of drawings in 1 week (both drawings and corrections)."

"Quicker decision making."

• **Freeze on changes:**

"Freeze on design changes before detailing work."

"Early freeze date for any client changes – zero client changes would have enormous effect on efficiency and profitability."

• **Accuracy / completeness:**

"Accuracy of information. Completeness/amount of design criteria. All this prior to commencement."

• **Information / communication:**

"Email."

"A single 3D-model used/developed by the whole project team."

"They never understand the information we require. Be willing to provide it and determine which party is responsible (engineer should be responsible in our view)."

(vi) How well are steelwork contractors information requirements understood?

Respondents were asked to rate how well their information providers appeared to understand their requirements. The ratings were:

0% Well

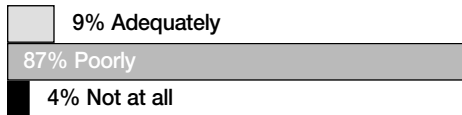

4.3 Summary of Findings

The overall picture emerging from this study was a positive one. The findings showed that the transition to electronic exchange of information had already begun. The benefits of better and more timely receipt of information by the steelwork contractor were recognised and quantified. The obstacles to be overcome in achieving this were also recognised as were current efforts by the industry to produce solutions.

The single most important issue emerging from the project was the necessity for the parties to have a better understanding of each other's need for information, rather than the mechanisms of data exchange.

Almost 80% of the survey respondents received information in digital form, of this number 89% found it either useful or very useful; 44% found it better than the conventional paper form and 39% found it the same. While there was some negative

feedback the vast majority of responses were positive and encouraging.

In general, at least 50% of steelwork contractors felt that the quality and adequacy of information received was either inadequate or bad and arrived either late or too late. By contrast almost 50% of respondents predicted a 10% saving in out-turn costs and 73% predicted a reduction in lead times of two weeks if improved information flow could be obtained.

Steelwork contractors felt that their information providers had a poor understanding of their requirements. Some 87% of respondents said their requirements were poorly understood while a further 4% felt their requirements were not understood at all. This response was an almost unanimous indictment of the present contractual arrangements and lack of knowledge of the other party's need for information.

5 Addressing the Issues

The National Structural Steelwork Specification for Building Construction is now in its 4th Edition; some fourteen years after the 1st Edition in 1989. It has continued to meet its objective of achieving greater uniformity in steelwork contract specifications and is recognised as a document that can be incorporated readily into contract documentation to specify acceptable standards for the fabrication and erection of steelwork structures for buildings.

The first section of the current NSSS (and all previous editions) sets down the information required by the steelwork contractor in order to undertake the contract. As early as the 'Foreword', the issue of information flow is raised, where the following statement is made:

'It is essential that the Steelwork Contractor receives, on time, all information necessary for him to carry out the contract. With this in mind, Section 1, which gives guidance on the items and information that should be included in the Project Specification, has been rearranged to make its purpose more apparent.....'

'Account is taken of the fact that information is increasingly exchanged in electronic form and the adoption of standard forms of steelwork connections allows the review of structural details to be streamlined.'

In BCSA's Commentary on the NSSS, the following statements are made concerning Section 1 of the NSSS – Information Required by Steelwork Contractor:

'This section of the NSSS may be considered as the interface between other contract documentation and the NSSS. It describes information that is needed to undertake the work in fabricating and erecting steel structures. The Steelwork Contractor can only do the

work and properly fulfil the contract conditions if the necessary technical information is complete and provided to an agreed programme.....

Whatever the circumstances of the contract, the quality of the finished steelwork and the speed and smooth running of the project are dependent on the parties being properly informed. Assembly of the information listed will be a valuable insurance against argument, misunderstanding and financial claims.'

Ideally, the information required (listed in the NSSS as a series of checklists) should be available at Tender Enquiry, such that an accurate tender price responding to all the issues can be prepared. The information for any contract must be complete and handed over as part of the contract documentation, but all too often it is not complete.

The NSSS sets down the information in the following structure:

- Table 1.1 Proposed Works Checklist (3 items)
- Table 1.2A Design Checklist (18 items)
- Table 1.2B Design Checklist (10 items)
- Table 1.2C Design Checklist (6 items)
- Table 1.3 Workmanship Checklist (6 items)
- Table 1.4 Erection Checklist (10 items)
- Table 1.5 Protective Treatment Checklist (7 items)
- Table 1.6 Inspections and Tests Checklist (2 items)
- Table 1.7 Programme Checklist (4 items)

Reference to the NSSS, its Commentary, and this Section 1 in particular cannot be too highly recommended. As an example of the breadth of information listed as being required by the Steelwork Contractor, Table 1.2A and 1.7 are set down below.

TABLE 1.2A DESIGN – CHECKLIST

When the Steelwork Contractor carries out detailing of the steelwork and design and detailing of connections based on the member design prepared by the Engineer

Information required by the steelwork contractor

- (i) A statement describing the design concept.
- (ii) Design Drawings showing all dimensions relevant to the steelwork or, when agreed, equivalent electronic data.
- (iii) The design standards to be used for connection design.
- (iv) Information necessary to design the connections including forces, moments and their combination required to be transmitted at each joint. Where connection design is to be in accordance with BS 5950, the forces and moments should be the factored values as defined by the code.
- (v) Particulars of any aesthetic, structural or clearance limits to be observed or environmental conditions which may affect detailing or protective treatment.
- (vi) Details and locations of any temporary works assumed by the Engineer in the design.
- (vii) A schedule of drawings, calculations and other information which the Steelwork Contractor must submit for acceptance.
- (viii) Any part of the steelwork where the manufacturing processes must be restricted eg plastic hinge positions.
- (ix) Details of any dynamic or vibrating forces and where fatigue is to be considered. Appropriate amendments to this Specification should be included since these factors are outside the intended scope.
- (x) The material grade and designation of steel to be used, including any of the options noted in standards listed in Table 2.1.
- (xi) Positions on the structure where additions and stiffeners are required to develop the strength of the member, and where notching may affect member stability.
- (xii) Any grades of bolt assemblies and their coatings which are specifically required.
- (xiii) Details of the fixings or bolts to the foundations or walls designed by the Engineer, or a statement indicating that the Steelwork Contractor has to design these items and prepare a Foundation Plan Drawing (see 3.3).
- (xiv) Any prescriptive requirements on thickness and type of bedding material (grout) to be used under column base plates.
- (xv) Requirement for any particular type of fabrication detail and/or restriction on types of connection to be used.
- (xvi) Details of cutouts, holes or fittings required for use by others.
- (xvii) Camber and presets which have to be provided in fabrication so that continuous frames and other steelwork can be erected to the required geometry.
- (xviii) Locations where holes cannot be punched (see 4.6.4).

TABLE 1.7 PROGRAMME – CHECKLIST

Information required by the steelwork contractor

Note: Programme dates may be those suggested by the Steelwork Contractor and accepted by the Employer.

- (i) The date(s) of issue of the Design Drawings or data for construction and other information necessary for the progress of the Works.
- (ii) The period to be provided in the Steelwork Contractor's programme for acceptance of submitted information.
- (iii) The date(s) by which the Site is expected to be ready with foundations prepared, free from obstruction, and accessible; with working surfaces, access roads and storage areas prepared and services available.
- (iv) The proposed starting and completion dates for erection of steelwork and the dates when other contractors' activities are expected to interface with the steelwork erection programme.

CHAPTER 17

Software

By Richard Dobson, CSC (UK) Ltd and Andrew Miller, RAM International (Europe) Ltd

1 Introduction

Today's software tools are a major reason why the work of engineers and technicians has been significantly altered. Gone are the days when engineers had to manually distribute loading on to each member and design members one at a time, then prepare designs and sketches to pass information on to the technicians. Gone are the days when technicians spent days preparing 2D general arrangement drawings in CAD. Gone are the days when other members of the design team had to spend days working out quantities and then the steelwork contractor spent weeks producing detailing drawings for the fabrication shop.

Today's sophisticated software packages automate and integrate these tasks to reduce labour and to introduce more efficient communication between the design team members. The software tools are not standing still however, and the good news for steel construction is that the integration of design, drawing and detailing processes for steel framed buildings is moving forward.

This chapter describes currently available software for designing, drawing, detailing and managing information into a functional context, addresses the current trends for 3D-modelling and discusses the current methods for transferring information models between these processes.

It should be noted that in this chapter, the term design office is used to indicate either the structural design office within a consulting engineering practice or the structural design office within a design-and-build steelwork contractor.

2 Software in Context

From concept to construction of a building, the industry players perform a whole host of different processes to effect completion. Today, many of these processes are undertaken or aided by the use of software tools. The principal reasons for the use of any tool should always be that it results in increased efficiency or a higher quality end product.

Originally, these tools performed point-specific tasks, but, with progress over time, tools have become more complex and have even started to integrate processes (for example analysis with design). Increased sophistication of both the computer and software has also led to solid modelling – a natural enhancement of

the design process. In order to explore the use of software tools, it is important to look first at those using the tools and the processes to which they are currently being applied.

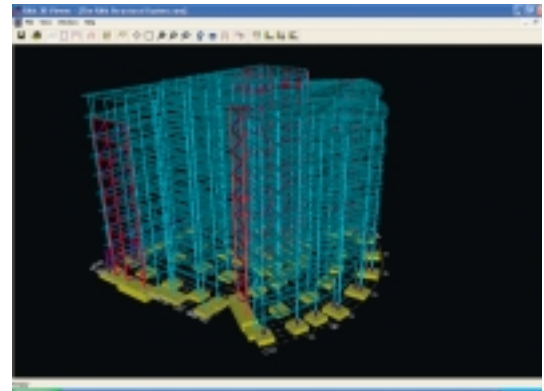

Rendered 3D model of a steel structure

2.1 The Design Office

In the structural design office, there are two key processes that are undertaken to move the development of the building design forward – structural design and development of drawings. First the design engineer creates information and second the engineering technician prepares the information for communication to others.

Currently, in the design office there can be said to be a "paper wall" between the design engineer and the engineering technician (see Dobson 2001 in references for this chapter). Information has typically crossed this boundary on paper. With progress over time, this is changing to be automatic transfer of information or "models". For the sake of clarity, the two sides of this wall can be classed as:

- "Model-Design" – the design engineers' side, the software typically includes:
 - Tools dedicated to the definition, analysis and design of steel and composite multi-storey buildings or steel multi-span portal frame buildings.
 - Tools for the definition, analysis and design of general structures whether they be in steelwork and/or RC and/or timber.

- "Model-Draw" – the engineering technicians' side, software typically includes:
 - Tools dedicated specifically to the modelling and automated drawing of general steel, concrete and timber structures.
 - Generic tools for the development of drawings and models and associated general arrangements (for instance AutoCAD, ADT and Microstation).

As shown in the following illustration, the "paper wall" is beginning to be breached allowing information to flow electronically by "export" of information from a "model-design" software tool and by "import" of the same design model into a "model-draw" software tool.

As well as internal office communication between processes, the illustration also shows that external links are being made electronically in other directions – for instance, into detailing and the management information system (MIS), particularly those that steelwork contractors use to control their manufacturing processes.

- "Model-Detail" software tools typically permit the creation of a steelwork model for:
 - connection design and detailing
 - automatic generation of up-to-date detail drawings and material lists
 - generation of information for numerically controlled (NC) and computer numerically controlled (CNC) machines for the cutting and drilling processes in the fabrication shop
 - generation of erection drawings
- The MIS embodies many of the steelwork contractor's core processes such as:
 - estimating and tendering
 - drawing management
 - ordering and stock control
 - material management
 - production tracking and management
 - shipping/delivery management

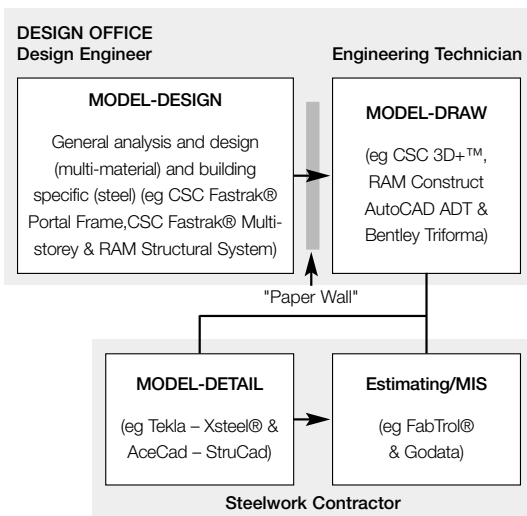

Software processes being applied currently

2.2 The Steelwork Contractor

The typical steelwork contractor has many systems that increase the efficiency of the business. Today, there are two primary ones that drive the steelwork contractor's production processes; the detailing system, which can be referred to as a "Model-Detail" software tool, and the MIS, which helps to manage the steelwork contractor's internal production processes.

3 3D Modelling

For over a decade, steelwork contractors have been using 3D modelling systems for detailing, and now there are an increasing number of design offices also taking to 3D for both the "model-design" and "model-draw" activities.

The question is why are engineers turning to modelling buildings in 3D? The answer lies in the efficiency and speed it can bring to the process. It also lies in the value that viewing and "walking through" a 3D prototype of the structure can have for the design team, and in presentations to clients (see Miller 2002). In addition, the 3D model can be used for clash detection and to provide an environment for the simulation of construction phasing thereby proving invaluable in eliminating errors and other problems before they occur on site.

Given that today information can be transferred reasonably between software packages, it makes eminent sense for a model created for analysis or design purposes to flow into the drawing process and on to other processes external to the design office.

Using a 3D model, once engineers have a suitable preliminary design, they can automatically obtain calculations, material take-off quantities and CAD general arrangement drawings – floor plans and elevations – all from the model. The result is a significant reduction in the time requirement to produce a very high quality design, as well as providing a wealth of information from the model. The key with this type of process is that the design software is the flexible engineering tool that the user needs.

One aspect of the design process which eats into the engineer's fee is accommodating change. For example, it is reasonably easy for an architect to reposition a column in a building – but this can have huge implications for the structural engineer. Such changes can result in a major redesign of supported beams, transfer beams, columns, base-plates and foundations. In addition to the design change, material take-off and the associated steelwork drawings require amendment.

Therefore, a simple change by the architect traditionally resulted in hours, or days of additional work for the engineer. Design development is an important aspect of the structural engineer's work, but it is a phase which is usually loathed. However, by using 3D modelling systems, the engineer simply has to change the model and the subsequent engineering information is regenerated. Consistency is maintained and potential errors are reduced.

Today, software tools can offer significant productivity benefits not only because they can perform repetitive

tasks quickly but also because they now permit "true" real-time visualisation and offer the ability to store and pass on real information to other disciplines and other parties. All of these advantages have great potential benefit to the building designer.

4 Information Exchange

Software is now capable of assisting in the communication between engineers, technicians and steelwork contractors through Electronic Data Interchange. EDI is the generic term used for the electronic transfer of data from one software package to another.

Information flow between design packages, drawing packages, detailing packages and an MIS is by file. The file contains information about the structural components in the model, ie one package exports information in a form that a second package can import (see Dobson 2003).

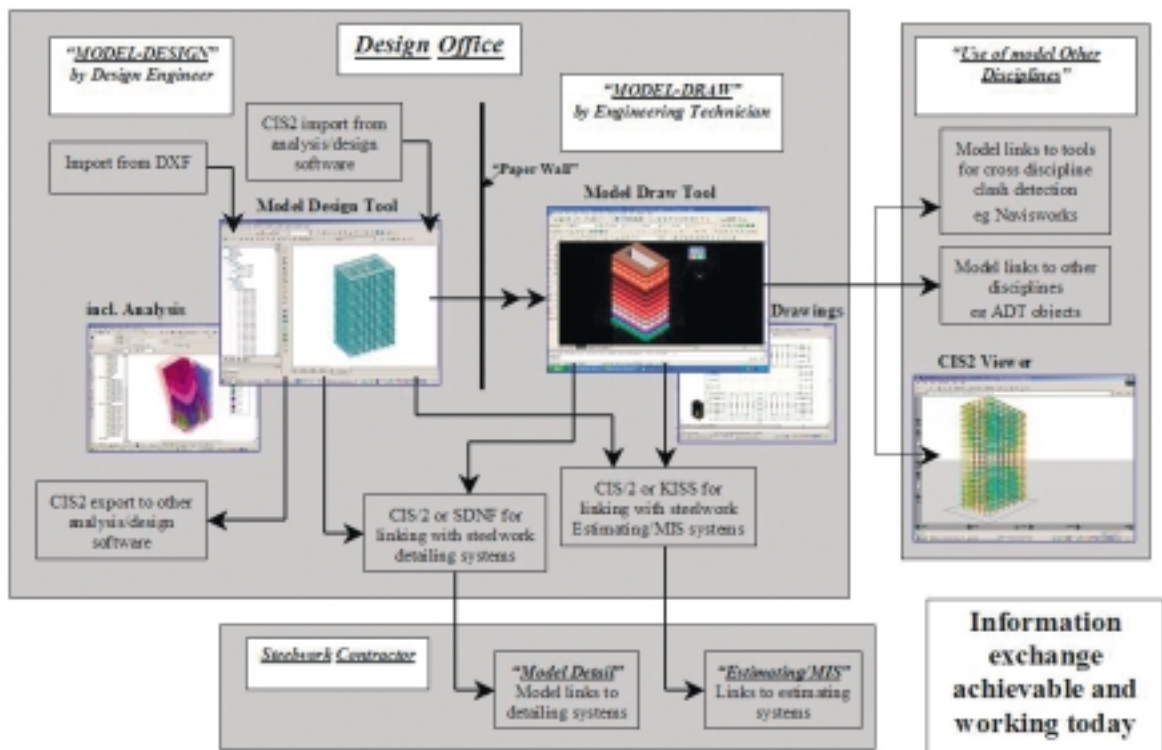

Information exchange available and working today

4.1 From the Architect

Typically, an engineer will receive information from an architect in one of two forms:

- 2D – on paper or by drawing file (typically .DXF .DXF or .DGN). The design engineer can use this information in a crude sense to start the design process, by reading from the drawing or electronically tracing the grids and layouts from the architect's information. The limitation of the 2D process is found as soon as a change occurs because all updating of information by the structural engineer has to be performed manually.
- 3D – typically an AutoCAD ADT model or a Bentley Architecture model. The 3D model can be used as a start for the concept design process. It is fair to say that currently the majority of architects still do not work using 3D drawing software.

4.2 Within the Design Office

Within a design office, information is typically passed between "Model-Design" packages in one of two ways:

- Native file format (most commonly) – package A writes out the information in package B's native file format.
- Neutral format (emerging) – package A writes out a file in a neutral format, one that is neither A's nor B's but is neutral to both.

A typical example of this is the CIMsteel Integration Standard (CIS/2) (see references), developed by Leeds University and the Steel Construction Institute. The CIS/2 is a protocol through which individual programs can communicate with each other – it is more encompassing for steelwork than previous formats and allows information to be passed from the design and analysis phase all the way through to the detailing, fabrication and generation of bills of quantities.

Since the adoption of the CIS/2 by the American Institute of Steel Construction (AISC), links between design office software packages are being facilitated and are becoming used more widely.

Once a design is complete or partially complete, information crosses the "paper wall" from design engineer to technician in one of three ways: as simple 2D GAs, elevations and sketches, in native file format or in neutral format. As time goes on, information will also be transferred more widely using the International Alliance for Interoperability's (IAI) Industry Foundation Classes (IFC) (see references). The IAI has a much wider remit than CIS/2 and their IFC's are intended eventually to address the breadth of construction from the

architect's walls and doors, to the structural engineer's beams and slabs (in any material), the mechanical engineer's piping to the end user's desks and PCs.

4.3 From Design Office to Detailing and on to the MIS

Information transfer between the design office and the steelwork detailer is typically being achieved using neutral files, although exchange using simple 2D Gas and elevations is still common. There are two principal formats available for neutral file transfer at this stage:

- The "steelwork detailing neutral format" (SDNF) is the most commonly used, although it has significant limitations. SDNF is a proprietary format developed by Intergraph. It is a simple practical route that does at least work.
- More recently CIS/2, which more packages are now supporting (see references for information on applications supporting CIS/2).

Information transfer between the design office and the detailer into the steelwork manufacturing processes is typically being achieved using neutral files:

- The KISS format is the most commonly used today. KISS is a proprietary format developed by Fabtrol.
- More recently CIS/2 (see above).

4.4 Limitations of Today's File-based Methods

Today's non-proprietary ("neutral") information flow is essentially file based, ie one software tool exports a file and the next imports it. Unless the sending or receiving software has significant in-built intelligence, this file based process has two principal limitations:

- Information that is transferred between software tools has to be the lowest common set of information which is understood by both tools. For instance, if tool A can handle bolts but tool B cannot, then information travelling between A and B and back will always lose the bolt information.
- Changes to information in one software tool have to be re-transferred into another; this does not happen automatically. When this happens, as it inevitably will, the receiving software tool, B, needs to recognise and deal intelligently with change. For instance, a beam in software tool A is moved and all necessary re-design is done. The changed model is re-imported into software tool B. B does not know whether the original beam has been deleted and replaced by a new one or whether the original beam has just moved.

If B can recognise the change as a move then all the extra information originally created in B can be kept with the moved beam.

Thus, the effectiveness of today's file based information exchange is dependent upon the intelligence of the software tools that send and, in particular, receive information. If the software is intelligent in recognising change and not losing information, then a file based solution can have significant value. However this is totally dependent upon the human management process in place around the use of these tools and the necessary validation and verification being adopted.

5 The Building Information Model Debate

The file-based nature of the processes currently in use inherently introduces the weaknesses mentioned above. The solution to these problems lies in a model which sits beneath all the software tools that work on it, a central model. To enable a central model within the context of the steelwork industry is a massive task, where the technical issues pale into insignificance when considered alongside the cultural, legal and political issues.

This is a massive subject that the industry is currently grappling with and the best introduction into this is the debate between AutoDesk and Bentley about Building Information Modelling (see references).

Suffice to say the totally integrated Building Information Model can be seen as an obvious future but how far away is it? It is the authors' belief that a full implementation is likely to be beyond our working lives.

CHAPTER 18

Selection of Steelwork Contractors and Suppliers

By Gillian Mitchell MBE, BCSA

1 Introduction

This chapter deals with the selection of steel construction related specialist contractors, components, materials, suppliers and services. Steelwork contractors can undertake the design, fabrication and erection of structural steelwork. In selecting companies appropriate for a particular contract consideration needs to be given to:

- the type of work;
- value of the work package;
- geographical location;
- QA certification;
- track record on quality of work and reliability;
- competence;
- health & safety record; and, of course,
- competitiveness on price and lead times.



Category C Steelwork - Volclay, Wallasey - Henry Smith (Constructional Engineers) Ltd

The Health and Safety at Work etc Act has been law since 1974. One of its many consequences is to encourage employers to take the safety of the employees they employ very seriously. The intent of the Construction (Design and Management) Regulations is to ensure that Clients insist on the same safety standards from the contractors they employ as they would for direct employees. Responsibility for ensuring safe practice cannot be avoided by subcontracting.

2 Industry Organisation

The national organisation for the steel construction industry is The British Constructional Steelwork Association Limited and all of its members support the principal objectives of the Association which are to develop the use of structural steelwork and to assist specifiers and clients to achieve cost effective solutions. From the support of research and development, promotion and market development of steel to the representation of the industry on national and European standards committees and at all levels of government, the Association remains at the forefront of positive change and improvement for the benefit of the industry. BCSA represents the industry both in Europe and internationally through membership of the European Convention for Constructional Steelwork (ECCS).

2.1 Membership Categories

BCSA Member companies undertake the design, fabrication, and erection of steelwork for all forms of construction in building and civil engineering. Associate Members are the principal companies involved in the purchase, design or supply of components, materials, services, etc related to the industry. Corporate Members are clients, professional offices, educational establishments etc that support the development of national specifications, health & safety, quality, fabrication and erection techniques, overall industry efficiency and good practice.

Member companies are regularly updated on the latest developments and changes in codes, standards, health & safety, forms of contract, etc. They also have access to professionally qualified help and advice.



Category D Steelwork - Times Square, London – William Hare Ltd



Category E Steelwork - B & Q Warehouse, Portsmouth – Frank H Dale Ltd

A full detailed list of members can be found in the BCSA's White Book – the "Steel Construction Industry Directory for Specifiers and Buyers", which is freely available to specifiers as well as being on the BCSA website at www.SteelConstruction.org.

There are also Supervisor [Gold], Manager [Platinum] and Contracts Manager [Black] cards available through CSCS for supervisors, managers and contracts managers in their own right, ie not specifically connected to steelwork skills.

Further information can be obtained from the CSCS Helpdesk (Tel: 01485 578777) or on www.cscs.uk.com

3 Certification

3.1 Company Certification

Many companies have third party Quality Assurance Certification via either the industry scheme, which is the Steel Construction Certification Scheme (SCCS), or other schemes such as those run by BSI and Lloyds Register. Increasingly some companies also have Environmental Management Certification and Health & Safety Certification.

3.2 Qualification of Personnel

There is a requirement for individuals working on steel construction sites to have a BCSA/CSCS card. Under this Construction Skills Certification Scheme there are four cards for steelwork erectors and steelwork fabricators:

- Red Trainee Card
- Green Construction Site Operative Card
- Blue Skilled [Skills to NVQ2 Standard] Card
- Gold Skilled [Skills to NVQ3 Standard] Card



Category L Steelwork - Terrace Balustrading – Glentworth Fabrications Ltd

4 Registration

The Register of Qualified Steelwork Contractors (RQSC) is more than just a list of companies as each applicant company must qualify by being audited by specialist auditors who check the company's financial resources, technical resources and track record. The Register has been developed with advice from major construction clients and can be used to select a steelwork contractor who has the special skills to suit a particular project.

4.1 Process of Registration

The Register's experienced professional auditors visit all companies to assess their capabilities in 11 subcategories of building steelwork and six subcategories of bridge construction. From the company profiles provided by the RQSC, a tender list can be matched to the particular demands of a project. The Register also classifies companies by suggesting a maximum contract value that is appropriate to their resources. The Register is to assist clients to select appropriately pre-qualified contractors, and is not a quality assurance scheme, but it does list the quality credentials of the registered companies.

4.2 Selection of Appropriately Qualified Companies

Although the CDM Regulations expect that Clients, Designers and Principal Contractors will take steps to select appropriate contractors, they will not be expert in steel construction. However, it is a reasonably practicable solution to rely on the Register, as experienced auditors have visited the companies and assessed their competence based on track record, personnel and resources. The use of a registered company matched to the demands of the project is a prima facie defence to any allegation that insufficient care was taken in selecting a competent contractor.

There are over 65 companies on the Register, and this provides users with plenty of choice to ensure a competitive tender list. By using the Register to match companies to suitable tender opportunities, the danger of a company submitting an unsustainably low price is removed. This is the best way of ensuring that the successful tenderer is then able to finish project.



Category F Steelwork - Factory, Swadlincote – Bison Structures Ltd



Category H Steelwork - TAG Aviation Hangar, Farnborough – Rowecord Engineering Ltd

4.3 Categories

The Register has two sections: Buildings and Bridgeworks, each split into various categories/ subcategories of type of work.

Each type of steelwork has a range of competence criteria (including managerial and technical) attached to it upon which companies will be assessed. This is not a 'tick list - in or out', but criteria for assessors to consider when coming to a decision, including:

- Facilities based on fixed assets declared in accounts
- Property as split by site location and site and building area
- Fixtures and fittings including computer equipment
- Plant and equipment
- Cranes
- Personnel skills based on numbers declared in accounts
- Design and documentation
- Fabrication
- Erection
- Planning and control of projects
- Management of the organisation
- Health & Safety Policy and record
- Environmental Protection Policy and records
- Equal Opportunities Policy



Category J Steelwork - The Whittle Arch, Coventry – Westbury Structures Ltd



**Category K Steelwork - Ulsta Navigation Tower, Shetland Isles
- Dew Construction Ltd**

Buildings Categories

In the Buildings Scheme companies may be registered in one or more categories to undertake the fabrication and the responsibility for any design and erection of:

- A All forms of steelwork (C-N inclusive)
- C Heavy industrial plant structures
- D High rise buildings
- E Large span portals
- F Medium/small span portals and medium rise buildings
- H Large span trusswork
- J Major tubular steelwork
- K Towers
- L Architectural metalwork
- M Frames for machinery, supports for conveyors, ladders and catwalks
- N Grandstands and stadia
- S Small fabrications

Bridgeworks Categories

The categories on the Bridgeworks Scheme, based on evidence from the company's resources and portfolio of experience, are:

- PT Plate girders [>900mm deep], trusswork [>20m long]
- BA Stiffened complex platework in decks, box girders, arch boxes
- CM Cable-stayed bridges, suspension bridges, other major structures [>100m]
- MB Moving bridges
- RF Bridge refurbishment
- FG Footbridges and sign gantries
- X Unclassified

4.4 Classification

The scheme is divided into ten 'Classes', each giving a recommended maximum project size (based on annual value if the project duration exceeds one year). Registration into a 'Class' is dependent upon financial criteria such as turnover, assets, insurance, etc. The Classes range from "Up to £40,000", in steps up to the largest steelwork contracts "Above £6,000,000".



Category M Steelwork - BOC Plant - Bourne Steel Ltd



Category M Steelwork - The New Trinity Road Stand, Aston Villa Football Club – James Killelea & Co Ltd

CHAPTER 19

Contracts and Payments

By Marion Rich, BCSA and John Davidson, Cyril Sweett Limited

1 Introduction

The contractual difficulties that face steelwork contractors are not unique to steelwork – they reflect those encountered by many trades within the industry, and most stem from longstanding and traditional practices, many of which are outdated in the context of how construction is now carried out in the 21st century.

This chapter does not give a detailed analysis of commercial and contractual matters relating to the construction industry – for instance, it is assumed that readers will be reasonably familiar with the generality of the provisions of Part II of the Housing Grants, Construction and Regeneration Act 1996 – but discusses those issues that are of particular importance to steelwork contractors.

The commercial and contractual problems discussed that affect steelwork contractors particularly acutely stem from three factors:

- steelwork is prefabricated;
- it requires a significant preliminary off-site period; and
- steelwork is the first trade on site after the piling contractors.

Steel construction was one of the first industries to use prefabrication – a move now being encouraged for a forward-looking construction industry. As such, steelwork contractors have a wealth of experience in this type of working, and do not find it a new or unusual way to do business. However, this, and the fact that steelwork is an "early trade", makes the design development phase crucial to programme performance – such that an early involvement in design and a definitive design sign-off are important.

In this regard, early involvement in design for steelwork contractors can lead to efficiency gains, and minimisation of programming difficulties and should be – but unfortunately is not always – reflected in the procurement method adopted. Long term the move is away from the 'traditional' types of contract to a more modern integrated approach. One long standing bugbear, with traditional procurement, relates to sign-off of design, which it is vital to do within the time limits agreed at the outset.

Prefabrication provides opportunities for cost-saving economies through the use of "factory methods". The corollary is that variations (especially those instructed

so late that they must be executed on site) are usually disproportionately expensive compared to the planned original cost of factory fabrication.

Steelwork contractors also suffer the same ills as others with regard to payment and retention issues – only again sometimes exacerbated because of the features that make steelwork unique.

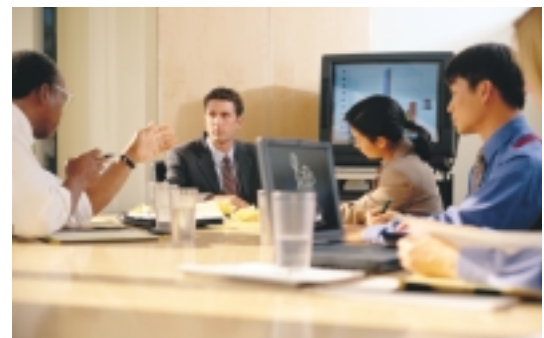

2 Early Involvement of Steelwork Contractors in Design

The traditional construction process is sequential, reflecting the input of designers first, followed by constructors and suppliers. This may not necessarily be in the best interests of clients, as it often acts as an effective barrier to utilising the skills and specialist knowledge of constructors and suppliers in the designing and planning of the project. No one person these days can fully grasp all the complexities of the various different sectors of a highly technical industry, as the construction industry now is.

Indeed, research undertaken by the Building Research Establishment in 1981 suggested that among the chief reasons for defects in construction were lack of design co-ordination, designs that lacked "buildability", and the fact that designers often did not fully understand the materials they were specifying. These conclusions would continue to stand without efforts to facilitate the early involvement of specialists in the design construction planning process.

These specialists are indeed knowledgeable in their own areas. Involving specialists early in the process also enables cost-effective solutions, using the most up-to-date solutions, to be used. The process of design is iterative and the involvement of both project designer and specialist needs to be acknowledged to allow the best to be got from both sides. The skills and

specialist expertise are there. Why not use them to improve your solutions for your client?

Early involvement in the design also leads naturally and beneficially to integration of the supply chain. Generally, this should include those parties who are pivotal in developing solutions that address the clients' needs. This was a key recommendation of studies that also noted that many clients feel that the performance of the industry has not been consistently good. Allegations are that resources are wasted through duplication of effort and communication is poor.

Another key identified to re-engineering the process beneficially is to build on previous experience by repetition of processes and solutions that work. Once a team is up and running its joint experience can lead to further gains, both financially and technically. Better solutions will emerge for clients – as well as better solutions for the contractors.

Thus "Accelerating Change, Rethinking Construction" reported:

'Supply side integration has a crucial part to play in increasing quality and productivity, reducing project times, increasing cash-flow efficiency and thus minimising risk, whether in terms of reduced costs from 'getting it right first time', or added value through ensuring that people work within 'process', not least so that health and safety risks are 'designed out' at source. Supply side integration delivers benefits during initial project delivery and by securing best value throughout subsequent use of the completed project.'

The message is clear: specialists have a wealth of design experience in their own field – it can and should be used for the client's advantage. There is a great deal of help around to facilitate this and two sources are given in the references for this chapter.

3 Sign-off of Design

Despite the moves to a more modern method of procuring steelwork outlined in the previous section, a large volume of steelwork is still procured traditionally. A great deal of tension between steelwork contractor and designer/client in traditional procurement arises from difficulties with the design. In a traditionally-procured project, design is supposed to be complete before the steelwork contractor is on board. In reality, of course, this rarely happens. Changes are made, insufficient information is given, information is given late or information is demanded that was not expected.

A mistake made by many within the steel construction industry as well as outside is to regard the work undertaken by steel contractors as assembling a 'Meccano kit'. This underestimates the reality that steelwork is precision engineering manufacture built to

tight tolerances using sophisticated software and machinery. Sometimes, the precision element of steelwork is overlooked because steel members are large.

So when problems occur, the difference in cost between work carried out in the factory and retro-fitting on site is a source of dissension for all concerned. Industry estimates are that to drill a hole in steelwork in the factory costs a few pence; to drill a hole on a piece of erected steelwork can cost upwards of £700. Such huge differences lead to bad feeling and disputes, but once the effect of time, safety provisions, delivery and hiring of necessary plant and equipment is taken into account, it is a realistic estimate.

So what should be done?

Where it is not possible for the steelwork contractor to be fully involved in the process of design from the beginning, there are two complementary ways of tackling this issue:

- Firstly, dates for the sign-off of design should be agreed before the contract begins. It should go without saying that these dates must be adhered to and must reflect the realistic periods needed for fabrication to begin.
- The second strand, which should avoid a great deal of the problems in the first place relates to the design itself. The steelwork contractor, as it has been pointed out before, is the expert in steelwork. The contractor would be pleased to help in identifying what information is needed. [In this regard, the Commentary on the 4th Edition of the National Structural Steelwork Specification, the 'Grey Book', goes into some detail about what information steelwork contractors require to be able to carry out their work.]



4 Programme

Unless it is formally incorporated into the contract as a contractual document, the programme does not usually have any contractual status. The primary contract between the client and the principal contractor would generally incorporate a contractually-binding Master Contract Programme. However, most programmes in use on the contract are simply management tools used by the contractors and contract administrators to measure and co-ordinate progress on the contract and do not form part of the contractual obligations of the parties. In contractual terms they may be seen merely as evidence of intent.

Unless a programme is agreed to be a contractual document, it will not usually be a breach of contract if the contractor fails to meet each date in the programme. Some non-standard subcontracts require steelwork contractors to proceed with their works at such time as the main contractor requires and sometimes even require the steelwork contractor to monitor the progress of the main works. The unfairness and even possibly impossibility of doing this should be plain to all.

The steelwork contractor, however, will not usually be entitled to expect complete continuity of working. However, entitlement to a claim for loss and expense would generally result if the steelwork contractor were significantly disrupted.

All this does not of course mean that the programme is unimportant. As a management tool, it is a vital instrument. The Society of Construction Law has published what it terms a 'Protocol' to provide guidance on issues that commonly arise in construction relating to time. It starts with a list of 'Core Principles relating to Delay and Compensation' and the first of these reads as follows:

'To reduce the number of disputes relating to delay, the Contractor should prepare and the Contract Administrator (CA) should accept a properly prepared programme showing the manner and sequence in which the Contractor plans to carry out the works. The programme should be updated to record actual progress and any extensions of time (EOTs) granted. If this is done, then the programme can be used as a tool for managing change, determining EOTs and periods of time for which compensation may be due. Contracting parties should also reach a clear agreement on the type of records that should be kept.'

The Protocol gives substantial guidance on preparing and maintaining programmes and records. It specifically states that the Guidance Notes are not designed to be incorporated into contracts, but are provided as guidance for contract drafters. Although largely relating to Client-Main Contractor relationship,

the principles espoused by the Protocol are equally valid all the way down the contractual chain and provide fair and equitable methods of dealing with the tricky subject of time in construction contracts.

Under most standard forms, the sub-contractor must carry out and complete the works in accordance with the agreed details and 'reasonably in accordance with the progress of the Main Contract Works'. Non-standard forms may deal with the situation somewhat differently. For steelwork contractors, the ability to be able to keep to the programme is substantially dependent on whether or not information is produced on time. Many non-standard subcontracts try and pass the risk of this to the steelwork contractor, but connections cannot be designed and steelwork cannot be fabricated until information – including loadings where necessary – have been produced.

5 Variations and Valuation of Structural Steelwork

Before discussing variations to, and valuation of, structural steelwork it is important to understand and agree what is included in the bill rates for the structural steelwork – assuming for the purpose of this chapter that the structural steelwork is measured in accordance with the rules of measurement contained in the Standard Method of Measurement of Building Works, Seventh Edition (SMM7).

Whilst bills measure and thus price structural steelwork there is often uncertainty as to what that each rate per tonne includes. Has the Bill of Quantities correctly measured all types of steel and the ancillary items, or has the quantity surveyor made a common mistake of assuming that all such miscellaneous items are "deemed included" within the each tonne rate?

If all the measurement rules of SMM7 have been followed correctly there should be no problem in using the bill rates as a fair basis for valuing variations.

When preparing a bill of quantities for structural steelwork it is imperative that, as well as following the measurement rules correctly, drawings accompany the Bills of Quantities. These drawings must show the following information:

- The position of the work in relation to other parts of the work and of proposed buildings.
- The types and sizes of structural members and their positions in relation to each.
- Details of connections or of the reactions, moments and axial loads at connection points.

Without this information the tenderer cannot accurately price the structural steelwork, thus increasing the risk of claims for variations being made due to "lack of information".

It is also important to ensure that details of "fittings for other trades" are shown on the drawings if it is intended that they are to be included within the overall tonnage of fittings and the associated rates. These fittings include such diverse items as pipe brackets, supports for services, stiffeners for mechanical, electrical and ventilating plant and also shelf angles attached to beams to carry floor units.

If "fittings for other trades" are not clearly shown on the tender/pricing drawings it is impossible for the tenderers' estimators to allow for the costs associated with their composition, location and method of attachment to the principal steel members.

What constitutes a variation? Apart from additional works there are many factors that might constitute a variation to the works. General Rule 4.6 of SMM7 lists what is deemed included in all bill items, unless specifically stated in the Bill of Quantities that they are not. These are:

- Labour and all costs in connection therewith.
- Materials, goods and all costs in connection therewith.
- Assembling, fitting and fixing materials and goods in position.
- Plant and all costs in connection therewith.
- Waste of materials.
- Square cutting.
- Establishment charges, overhead charges and profit.

If any detail of these items changes from that described in the bill description, drawings and/or specification, then a variation has occurred. It is therefore important for designers and specifiers to ensure that the correct information is provided at the tender/pricing stage. Especially important are the type and grade of steel, details of welding tests or perhaps the rather rare X-ray tests and details of any performance tests.

Provided that these recommendations are correctly followed, the valuation and subsequent agreement of variations should not present a problem.

6 Payment

Cash flow has been described as the 'life-blood of the construction industry', as without it survival is impossible.

6.1 Start of the Payment Cycle

Under traditional methods of procurement, the DOM/1/2 system of contracts is by far the most used standard form subcontract and is used as the basis for many, if not most, 'bespoke'

contracts. Generally, steelwork contractors do not mind working to these standard forms, but unfortunately the payment cycle in them does not start until after work on site has started. The problem is made vastly worse because the DOM/1/2 procedures and wording have become so familiar within the industry that they have almost become regarded as a form of 'construction common law'; people feel 'that is how things are done'. Somehow, people in the industry expect payment to be linked to start of work on site, although there is no objective reason why this should be so and good reasons why it should not.

With the consultant's agreement, it is possible to be paid earlier, of course, but this is not as of right. There is no reason why work done before goods are taken to site – in a steelwork contract, about 85-90% of the value of the contract – should not be paid for like any other work.

The suspicion must be that the system arose in the days when most work was done on site, but those days are long gone. Steelwork contractors are highly specialised in use of the new technology for fabricating the steel, planning and delivery. The 'Meccano kit' can be delivered just-in-time exactly as it needs to be erected. There is a powerful argument to say that payment practices should reflect what happens now, not what happened 100 years ago.

Arguably, this general picture of payment is inhibiting the development of modern forms of working. Off-site fabrication has increasingly come to be seen as the way forward. It allows faster, more certain, safer construction. It is also easier to maintain quality in the controlled conditions of a factory than on site. However, why move to off-site fabrication unless payment terms are amended to take account of this? A KPI to monitor payment practice, including when payment starts, is being drafted at the moment by the Construction Best Practice organisation.

6.2 Legislation

Two major statutes affecting payment in construction contracts are the Housing Grants, Construction and Regeneration Act 1996 and the Late Payment of Commercial Debts (Interest) Act 1998.

Housing Grants, Construction and Regeneration Act 1996

This Act applies to all contracts in writing entered into after 1 May 1998 which are for 'construction operations' as defined in the legislation. The definition of construction operations is widely drawn and will cover most works by steelwork

contractors, but with two major exceptions: supply only contracts, and erection or demolition of steelwork for the purposes of supporting or providing access to plant and machinery on a site where the primary activity is nuclear processing, power generation or water or effluent treatment. (However, where standard form contracts are used, then most if not all Construction Act provisions will be usually be incorporated into the contract in any case).

Among other payment provisions, the Act provides that where a sum due is not paid by the final date for payment and no effective withholding notice has been served, the payee has a statutory right to suspend performance of its obligations under the contract upon giving at least seven days notice to the payer that it intends to do so. This is often changed in contracts to extend the notice period to 14 or 28 days, or longer – occasionally as long as six months. This must be ineffective; the statute in this instance does not work by implying a term into the contract, the right to suspend is a direct statutory right. So the payee should be able to rely on its statutory right to suspend on seven days notice whatever the contract provides.

Late Payment of Commercial Debts (Interest) Act 1999

Whereby those subjected to late payment of their debts are entitled to interest as well as further small amounts by way of compensation for the late payment. The Act sets out a 'standard' rate for interest of 8% above base rate – it is designed to deter late payment as much as to compensate for it. It is possible to choose a different rate provided that the contract provides other 'substantial' remedy for late payment. What this means has not yet been tested in Court, but must be sufficient to compensate for the late payment, to deter late payment and it must be fair and reasonable in all the circumstances to allow the remedy to replace the statutory right.

7 Retentions

Many contracts still provide for sums of money to be retained from each interim payment to the steelwork contractor. This practice is commonly reckoned to be a guard against defects, although none of the standard form contracts specify why monies are withheld – certainly, the first half of retention, commonly released upon practical completion of the steelwork contract, cannot be for defects, as any defects arising up until that time would be dealt with under the normal payment provisions.

There is no evidence to show that retentions do anything to reduce defects. The evidence submitted by the Specialist Engineering Contractors' Group to the House of Commons Trade and Industry Select Committee actually shows that defects reduce when retentions are abandoned. It may be that this is because abandoning the use of retentions by enlightened clients is often linked to a change in procurement process. What retentions do guarantee is that steelwork contractors will either try and load the price or not have the incentive to work properly. The Parliamentary Committee on Trade and Industry referred to retentions as inefficient and frequently harmful.



For specialists such as steelwork contractors, the problem is particularly acute. Indeed, the Inland Revenue has recently changed its procedures in recognition that retentions are rarely paid on time even within the terms of the contract.

One of the main problems is that the second half of retention is normally not released until the final completion of the whole project. This has particularly deleterious effects on steelwork contractors, who are early on site. Sometimes, steelwork contractors can be kept out of their money for years when their own work is fine. This is abusive in itself, but the position is worse when most standard forms of contract are considered – typically, release of the second half of retention is linked to issue of a certificate under the main contract. There are doubts whether this practice of linking what happens under one contract to certification under another complies with the Construction Act. This Act requires that all construction contracts should contain an adequate mechanism for determining what payments become due under the contract and when. Yet how is that effected if one party has no influence or necessarily even knowledge of when certificates are issued, has no influence on the certification process, and has no recourse in the event that the certification process breaks down. Where a contract provides for this mechanism to be used, the scope for disputes – which it is in no-one's interests to promote – is widened.

Another problem arising when steelwork contractors are kept out of their money for three, four or more years is of course that they are at the risk of insolvency up the contractual chain for all that time. Although some main contracts provide for retention fund to be 'ring fenced', traditional subcontracts do not.

Where clients do not feel confident enough to abandon retention completely, a 'halfway house' can be achieved by use of bonds. It is worth remembering, however, that many steelwork contractors will already be required to provide a warranty to the client, usually including Professional Indemnity insurance, as well as often, a performance bond and/or a parent company guarantee. All these add to the cost with very little benefit for the client.

The real alternative to retention is to choose the right steelwork contractor in the first place – competent contractors prevent defects, not retention. The use of the Register of Qualified Steelwork Contractors for this purpose is discussed elsewhere in chapter 18.

8 General

Further information about constructional issues related to steel construction is given in the BCSA's Constructional Handbook.

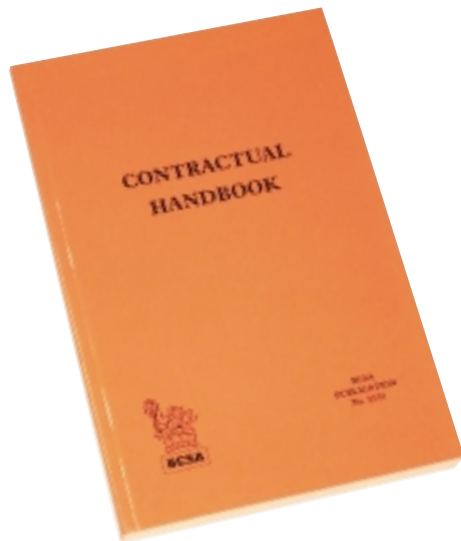

CHAPTER 20

Health & Safety

By Roger Pope, BCSA Technical Consultant

1 Introduction

Whilst concerns for health and safety are as important in the fabrication works and steel mill as they are on site, it is at the erection stage where the most visible aspects of unsafe practice might become apparent. It is also on site that design decisions and restrictions from other contractors can affect the steelwork contractor's ability to perform safely. Hence, this chapter focuses on site safety during steel erection.

It is a common but unfounded view that steel erection is risky. Statistics show that neither steel erection nor falls from steel are near the top of the worst offences lists. Certainly it is hazardous but not risky, as with proper management by a competent steelwork contractor the risks can be removed or controlled.

The hazards arise from three of steel construction's inherent characteristics:

- Large, heavy components must be lifted and placed into position.
- The structure can be unstable in the part-erected condition.
- Each project is different.

1.1 Steel the Safe Solution

However, these hazards apply to other structural framing materials as well, and arguably steel is the safest solution in this regard. Designers are obliged to consider whether their schemes can be safely built and dismantled. The choice of material for the building frame has a major influence on what is achievable.

The nine factors that make steel framing the "safe solution" are:

- Steelwork is **pre-engineered** in a way that makes pre-planning of operations easier and more certain.
- A **virtual reality** model of the steel frame can be built in three dimensions in the computer thus facilitating detailed planning of the erection procedure.
- Steelwork is **prefabricated** offsite, which makes it accurate and less liable to errors that would generate site hazards.

- Steelwork is **standardised** in a way that leads to repetition of site tasks and hence greater certainty of safe practice.
- Steelwork provides a **framed solution** that can be self-stable with immediate availability of the full strength of the material.
- **Safe access** to working positions can immediately be gained using already erected parts of the steel structure.
- Where necessary, steelwork can be **trial erected** to establish the best method of subsequent safe erection on site.
- Steelwork is **easily modified** if necessary during maintenance or refurbishment.
- Steelwork is **readily demountable** should demolition be necessary.

1.2 Default Solutions

In addition, the basic concepts behind steelwork erection are easily understood in terms of the following default solutions:

Single storey construction

- Start by erecting a **braced bay** to provide stability.
- Use a mobile **telescopic crane** that can traverse the site.
- Gain access to working positions using mobile elevating work platforms – the ubiquitous MEWP or "cherry picker".



Multi-storey construction

- Use a **stair core** to provide stability.
- Lift and place steelwork with the **tower crane**.
- Gain access from **metal decking** or precast planks already placed on the floor below.



Metal decking or precast planks

- Ensure the steel frame is **aligned and stable** to receive decking or planks.
- **Integrate sequence** of installation with the progress of steelwork erection to allow the same crane to lift the elements and place them in position.
- Access over the erected elements and provide **nets and edge protection** for general protection.

1.3 Stability, Craneage, Access

The designer has differing obligations concerning the three safety objectives that underpin these default solutions:

Stability



How can stability of the part-erected structure be maintained? This the designer **MUST** address as errors in ensuring that the steelwork contractor has a clear understanding of the designer's stability concept would generally rebound on the designer.

Craneage



What craneage is needed for lifting and placing the steelwork? Whilst the designer would not ultimately select the crane, clear assumptions on lifting capabilities should underlie the choices made in the scheme design (eg about splice positions and hence piece weights).

Access



How can safe access to and at working positions be arranged? Often the designer would have no more than a general awareness about access provision – enough to confirm that the general assumptions in the default solutions are valid.

2 Hazard, Risk and Competence

To ensure that the hazards of steel erection are safely dealt with, the risk assessment at design stage should insist that a competent steelwork contractor is chosen. As explained in more detail in chapter 18, to assist the choice, the Register of Qualified Steelwork Contractors [RQSC] classifies all its contractors against two criteria:

- For what categories of work (eg high rise buildings) does the contractor have a proven track record?
- What is the recommended maximum size of contract that can be safely resourced and managed by the contractor?

The categories of work used by RQSC are general and the precise scope of work demanded by each project will differ. Thus, the first priority for competent contractors is to ensure that the scope of work can be safely undertaken with the resources of know-how, manpower, equipment and finance at their disposal. For this purpose two checklists of competences have been prepared:

- **Normal** steel construction activities that steelwork contractors should be competent to undertake with their own personnel
- **Special** activities that steelwork contractors should be able to manage using specialist subcontractors as necessary

Having checked at tender stage what a project demands, steelwork contractors should warn designers if they are unable to undertake any of the normal activities, and designers should check beforehand whether a steelwork contractor is willing to undertake

any of the special activities. There are many competent steelwork contractors, and, on behalf of the client and themselves, designers should check that the principal contractor is taking suitable steps to select one.

Normal Scope of Competence

Normal steel construction activities that steelwork contractors should be competent to undertake with their own personnel.

1. Slings, handling, lifting and positioning steelwork.
 - Steelwork includes fabricated hot rolled and cold-formed steel sections.
2. Aligning, levelling and plumbing steel frames.
3. Securing and bolting up steelwork.
4. Operating the necessary mobile elevating work platforms [MEWPs]
5. Setting out.
6. Acting as a banksman.
7. Caring for and use of lifting tackle:
 - Purpose-made lifting tackle, such as lifting beams and bracings to stabilise frameworks during rearing and lifting, may need to have their capacity proof tested.
8. Use of jacks.
9. Welding and cutting:
 - The use of burning equipment and welding equipment (with or without pre-heat) is "hot work" and particular fire precautions are always needed.
 - The Commentary on the NSSSBC lists factors to be considered when undertaking site welding, of which the six listed below relate to safe practice:
 - Floor by floor completion to give good working areas.
 - Use of light easily erected working platforms.
 - Protection from inclement weather.
 - Careful detailing to ensure downhand welding.
 - Use of details and techniques to avoid the necessity for excessive pre-heating.
 - Provision of temporary means of support and stability until welding is complete.
10. Drilling or reaming using power tools:
 - The use of power tools operated by electricity should follow the advice given in the HSE's PM series of guidance notes.
11. Installing HSFG bolts:
 - If preloaded bolts - previously termed HSFG bolts - are used, there is a possibility for the bolt to break during tightening and for part of the bolt to shoot off (eg when the threads are in poor condition). Personnel should be careful not to stand in line with the bolts or in areas where the parts could fall.
12. Painting:
 - Site treatment can include site blasting as well as site painting. Additional precautions, such as the regular examination of air receivers, may be needed when using equipment powered by compressed air.
 - Additional precautions may be needed where paint coatings are heated by burning or welding operations.
13. Erection of metalwork items such as catwalks or metal flooring
 - The erection of all metalwork items - including railings, balustrades, stairs, walkways, ladders, catwalks, steel flooring of open-mesh or plate - may involve the need to manhandle items.
14. Placing precast flooring:
 - Whilst it is a normal steel construction activity to install precast planks on steel frameworks, the erection of precast concrete frameworks generally is not.
- The placing of precast planks may result in large point loads, and precautions are needed to ensure that the local and general stability of the part-erected framework is not jeopardised.
- The sequence of placing the planks needs to be carefully planned to preserve access for lifting and positioning subsequent items.
15. Drilling concrete.
16. Installing expanding/chemical anchors.
17. Guiding site visitors.
18. Refurbishment work:
 - The retention of elements of the existing building usually interferes with the provision of craneage for lifting and positioning operations. Hence there is a greater likelihood of manual handling for positioning.
 - Construction hoists are commonly provided for vertical lifts, and it can be hazardous if long components need to be moved in hoists.
 - The route selected for lateral movement needs to take account of the strength of the existing structure and its stability under surge induced by braking the movement of heavy components.
19. Work on a contoured site:
 - Dangers associated with operating cranes over contoured ground - especially for crawler cranes travelling under load - are described in CIRIA's *Crane stability on site*.
 - The same precautions apply to the operation of MEWPs over contoured ground.
20. Work on city centre sites:
 - Erection in city centres usually takes place on sites that are of a very restricted size, and public access is usually very close - sometimes being through part of the site plan zone. The customary designation of a "sterile zone" - accessible only to the steel contractor's personnel during erection - is often impossible, and site workers can be working underneath other workers. Hence risk, being the potential harm from hazards, increases.
 - It is more common for nets and fan scaffolds to be used on such sites. See BS 8093 *Code of practice for the use of safety nets, containment nets and sheets on constructional works*, BS EN 1263-2 *Safety Nets: Safety requirements for the erection of safety nets*.
 - The proximity of the public and adjacent buildings can also affect choice of craneage, limitations on noise, and permitted hours of working.
21. Connecting to an existing structure:
 - There are stability considerations for the designer to consider if connections are needed between a new structure and an existing one, and these determine the safe sequence of work.

The site may be traversed by members of the "public" - in the form of the client's personnel working on the site or in the adjacent building. This affects the potential for hazards to cause harm.

Special Scope of Competence

Special activities that steelwork contractors should be able to manage using specialist subcontractors as necessary.

1. Grouting bases.
 2. Placing bearings that allow movement.
 3. Installing a scaffold platform.
 4. Assisting second or third party inspection:
 - Personnel working for second or third parties may need to undertake inspections or witness tests. Additional precautions may be needed to ensure that their presence in the area designated for erection does not cause added risks.
 - Whilst ultrasonic inspections would be considered special, steel constructors would not normally undertake radiographic inspection at all.
 5. Use of special fasteners and fixing proprietary items:
 - Special fasteners are proprietary products for which no British Standard exists - *Lindaptors* and crane rail fixings are examples. The manufacturer's recommendations for installation should be reviewed against the requirements for safe erection - checking back directly with the manufacturer's technical staff if the written instructions are not sufficient.
 - Similar precautions apply to installation of proprietary items such as *Halfen* channels.
 6. Work on decking for composite steel and concrete structures:
 - For metal profiled steel decking, the SCI's *Good practice in composite floor construction* should be followed. Arrangements for edge protection and safety precautions along the leading edge of the work front need to be agreed.
 - Particular care is needed during the stage when the steel frame and decking are loaded with wet concrete.
 - Stud welding and shot firing are operations for which the equipment manufacturers issue guidance on suitable safety precautions. The use of cartridge operated tools should follow the advice given in the HSE's PM series of guidance notes. These operations can also require additional noise protection.
 7. Work in artificial light:
 - Shift work can also involve additional precautions.
 8. Extensive temporary works:
 - Whilst many temporary bracing and restraint requirements are relatively simply executed (eg wire rope guys, *Acrow* props or added strut-tie braces), extensive temporary works will require consideration of the guidance in BS 5975 *Code of practice for falsework*.
 9. Large scale site assembly "on the ground":
 - Assembly on site before lifting of the subassembly into its final erected position can be chosen as the most appropriate safe method of construction. However, the large scale of some subassemblies will require provision for safe access during assembly "on the ground" if working positions are at heights of more than 2 metres off the ground.
 - Any jigs or stillages used to support or stabilise the subassemblies need to be treated in the same way as temporary works supporting the structure in its final erected position.
 10. Lateral movement of heavy loads:
 - CIRIA's *Lateral movement of heavy loads* provides guidance on sliding, winching and braking operations.
 11. Work in a confined space:
 - HSE's GS 5 (rev) *Entry into confined spaces*, and *Confined spaces* [CIS no 15] provide suitable guidance.
 12. Work over water, over a railway or airside at an airport:
 - Clients and Principal Contractors should determine the appropriate additional precautions to be followed in these and other especially hazardous environments - such as mines, quarries and oil or chemical refineries. This would normally include permit-to-work procedures.
 13. Work on tall structures over 45m high:
 - Methods of achieving all three safety objectives are different on structures over 45 metres high, compared to those used on the most common type of steel structure - single storey sheds. For example, the influence of wind is much more significant.
- Other** activities related to steel construction that steelwork contractors **would not necessarily undertake** and about which specific prior negotiations should take place to establish the competences necessary, the methods to be used and the consequent risks involved.
1. Radiography or assisting radiographic inspection by third parties.
 2. Site blasting and use of compressed air equipment.
 3. Fixing preglazed frameworks.
 4. Erecting precast concrete frames.
 5. Using bonding adhesives.
 6. Fixing roof or wall cladding.
 7. Proof testing to commission runway beams etc.
 - Commissioning of runway beams involves proof loading which should be done under the direct instruction of a suitably qualified engineer.

3 Method Statement Development

Even before a competent steelwork contractor can be selected, design decisions must be made that affect what erection methods can or must be used. These may emerge in the development of the Pre-Tender H&S Plan or in the steelwork design process itself that depends on an assumed design-basis outline method of erection.

3.1 Site Conditions

Items to be considered in defining the site conditions suitable for safe erection:

- Access to the site and within the site.
- Limitations on dimensions or weights of components that can be delivered onto the site.
- Soil conditions affecting the safe operation of plant.
- Provision and maintenance of **hard standing for cranes** and access equipment.
- Details of underground services, overhead cables or site obstructions.
- Special environmental and climatic conditions on and around the site.
- Particulars of adjacent structures affecting or affected by the works.
- Possible settlement of supports to the structure during erection.
- Availability of site services and prearranged **procedures for cooperating with other contractors**.
- Value of construction and storage loads allowed on the steelwork.
- Concrete placement during composite construction.

3.2 Design-Basis Method of Erection

Further items to be considered in developing the design-basis outline method of erection:

- The position and types of site joints.
- The **maximum piece size**, weight and location.
- The **sequence of erection**.
- The **stability concept** for the part-erected structure including any requirements for temporary bracing or propping.
- Propping or other actions necessary to facilitate subsequent concreting of composite structures.
- Conditions for removal of temporary bracing or propping, or any subsequent requirement for destressing of permanent bracing.
- **Features which would create a hazard** during construction.
- Timing and method of grouting foundation connections.
- Camber and presets required including values to be checked at fabrication stage.
- Use of profiled steel sheeting to ensure stability.
- Use of profiled steel sheeting to provide lateral restraint.
- Possible method of providing **safe working positions**.

3.3 Construction H&S Plan

Later, the steelwork contractor will develop the full erection method statement as part of the Construction H&S Plan. This will tackle:

- Experience from any trial erection undertaken.
- The restraints necessary to ensure stability prior to welding and to prevent local movement of the joint.
- The lifting devices necessary.
- The necessity to mark weights and/or centres of gravity on large or irregularly shaped pieces.
- The relationship between the weights to be lifted and the radius of operation where cranes are to be used.
- The identification of sway forces, particularly those due to the forecast wind conditions on site during erection, and the exact method of maintaining adequate sway resistance.
- Exact methods of coping with any safety hazards.
- Exact methods of providing safe access to positions of work and safe working positions.

Liaison between the steelwork contractor/erector and the principal contractor is also needed to deal with the following hazards:

Poor Site Conditions

The CHSW Regulations make provision of a safe site the responsibility of the principal contractor. Where reasonably practicable the provision of safe access for steel erection should be by means of MEWPs. In accordance with Schedule 2 of the CHSW Regulations, this means that the Principal Contractor must provide a suitable site on which MEWPs can operate safely. It is not a reasonable argument that site conditions prevent access using MEWPs if those ground conditions are under the control of the Principal Contractor. Problems can arise from four particular sources:

- Soft ground arising from inadequate backfilling with hardcore.
- Contoured ground not yet reduced to final level.
- Trenches cut across lines of site access.
- Excessive mud leading to personal danger from slippery footwear.



Inadequate Segregation of Contractors

For a specialist trade such as steel construction, the preferred solution is the operation of exclusion zones that are wholly within the steelwork contractor's control. If this is not reasonably practicable, then the site arrangements must bear in mind the possibility of falling materials from operations overhead. Also, the stacking of steel components may be safe when undertaken by the steelwork contractor provided that other contractors are not allowed access to the storage area.

This dialogue should also tackle the arrangements for cooperation between contractors – eg fixings for netting and edge protection.



Netting



Edge Protection

Unforeseen Construction Loads

The stability of the part-erected steel structure can be jeopardised by "loading out" with excessive quantities of materials by following trades. The excess loads can arise from either self-weight of the construction materials or wind loading on them.

Weather Conditions

Each trade considers the effects of weather conditions differently. With the increasing use of MEWPs the risk is reduced compared with access over the steel frame itself. Hence it may be considered safe to undertake bolting-up from a MEWP in wet weather. High winds remain a hazard for lifting and placing steel components.

Programme Compression

Properly planned amendments to programme can be safely executed, but unforeseen hazards are likely to arise from frequent and drastic shifts in programme aspirations, particularly if the period for site work is compressed significantly.

4 Stability

Of the three key issues – **stability, craneage and access** – designers must chiefly be concerned with ensuring stability as only they have full knowledge of the concepts upon which the design is based. The concern is for stability during all stages of erection:

- of the assembled structure in its final condition,
- of assembled portions in the part-erected condition,
- of individual components during lifting and after placing in position, and hence
- for specifying the brief for any temporary works necessitated by the scheme design.

Some issues for the designer to consider are listed below.

4.1 Final Condition

Will stability be by means of permanent steel bracing or sway frames, or will it depend on other construction elements such as concrete shear walls?

Where will the permanent bracing be located?

Will metal decking etc be used as diaphragms?

How are load paths between components engineered?

4.2 Part-Erected Condition

How will potential frame instability be overcome?

How will the construction sequence dictate when load paths can be established?

What construction loads will be permitted?

4.3 Individual Members

Are any members susceptible to instability when being lifted and placed?

How could the need for lateral restraint be engineered?

What restrictions might there be on rigging arrangements during lifting (eg for attachment of guys to members)?

4.4 Temporary Works

Does the scheme necessitate any bracing or propping?

What forces and moments will develop in the temporary members?

How will forces in tension members be developed?

How will members be secured during site welding?

Are there restrictions on how the temporary members might be connected?

Steelwork contractors are responsible for designing the actual temporary works to be used as they must match their chosen erection methods, but they need a clear brief specified by the steelwork designer.

4.5 Connections

Often the steelwork contractor will undertake the design of connections, and there can be an interaction between the selection of connection types and the need for temporary bracing or the sequence of erection. For instance a fin plate would be less robust in the part-erected condition than a welded full-depth end plate. Similarly the choice of a column splice location could influence whether the column required stabilising by temporary guys when first erected. This in turn could depend on the design of the foundation itself and the column base connection.

In general, it is likely that the steelwork contractor would prefer to use standard details from the "Green Books" published by SCI/BCSA, and the designer should be safe in the assumption that a competent contractor would be fully familiar with how to fix such connection types and their implications on connection stability.

The corollary of the default assumption noted above, is that any special connection types should be given particular attention in terms of their implications for safe erection. For example, pin connections can give rise to a mechanism in the part-erected condition. This would need to be noted as a feature which would create a hazard during construction by whoever made the decision to select that connection type.

5 Best Practice

5.1 Dialogue

Just as with all aspects of realising the designer's scheme in terms of practical details, the secret is to promote a dialogue about such issues between designer and contractor, and this need for dialogue extends to several factors that contribute to developing a safe erection method.

As explained in chapter 15 this dialogue also supports the development of a sound project quality plan. It is generally the case that sound quality management procedures assist safe practice as unanticipated quality problems arising on site can often jeopardise pre-planned site methods. Similarly, as good planning is a key factor in safe practice, a high incidence of late alterations is bound to significantly increase the chance of unforeseen hazards occurring.

The market place also provides a wide choice of equipment for the contractor in terms of craneage and access. Steelwork contractors are well-placed to advise on what equipment is available. What is in relatively short supply, however, is good technical understanding of the implications of structural behaviour on erection methods – and it is this knowledge that the designer provides through the design-basis outline method of erection and the subsequent dialogue with the chosen contractor.



Stability, Craneage, Access

5.2 Further Advice

Free advice is available from every steel construction site that one passes or sees in photographs, such as those illustrated in this brochure. In this way lessons can be learned from the experience of

others. Contacting the steelwork contractors involved can also be a mine of advice and the contact details for BCSA members can be found on the BCSA's website www.steelconstruction.org.

Also available there are downloadable documents about best practice, tips for safer steel erection and copy of BCSA's *Safe Site Handover Certificate*. The SCI website www.steel-sci.org is a further source where details about publication P-162 *The Construction (Design and Management) Regulations 1994: Advice for designers in steel* may be found. Finally, BSI publishes BS 5531 *Code of practice for safety in erecting structural frames*.

CHAPTER 21

Sustainable Construction

By Roger Plank, Sheffield University and John Dowling, Corus Construction & Industrial

1 What is Sustainable Construction?

The best known definition of sustainable development is probably that given by the World Commission on Environment & Development in 1987:

"Development which meets the needs of the present without compromising the ability of future generations to meet their own needs."

Construction can make an important contribution to sustainable development both because of its overall importance to the national economy – as it accounts for 10% of GDP in the UK – and also because of the significant environmental and social impacts which it creates.

Sustainable construction can therefore be thought of as a subset of sustainable development and encompasses a wide range of issues, such as the re-use of existing built assets, design for minimum waste, minimising resource and energy use, and reducing pollution. In the UK, the government has made it clear that sustainable development is not just about minimising environmental impacts but also encompasses social and economic issues. Accordingly it defines sustainable construction as:

"The set of processes by which a profitable and competitive industry delivers built assets (buildings, structures, supporting infrastructure and their immediate surroundings) which:

- *enhance the quality of life and offer customer satisfaction*
- *offer flexibility and the potential to cater for user changes in the future*
- *provide and support desirable natural and social environments*
- *maximise the efficient use of resources."*

This chapter discusses the key issues of sustainable construction, explains what steel construction in particular has to offer and how these benefits can be realised.

2 Drivers for Sustainability

Within the UK, the government has sought to encourage, rather than coerce, the construction industry to adopt the principles of sustainable development. Nevertheless, legislation such as the Landfill Directive and the Environmental Protection Act,

and fiscal measures such as the Primary Aggregates Tax and the Climate Change Levy are having a significant impact on organisations within the construction sector.

The challenge is for business to move towards socially and environmentally responsible policies while, at the same time, maintaining economic viability. Many organisations are doing just that and the World Business Council for Sustainable Development has lent its support – business can benefit from pursuing sustainability in two ways, by generating top line growth through innovation and new markets, and by driving cost efficiencies.

Socially responsible investment is also increasing pressure on companies to adopt sustainable practices.

The steel construction sector has published a strategy which includes a review of how the sustainable development agenda is being addressed within the UK steel construction sector. This has demonstrated that the sector is an efficient, competitive industry; that steel framing and cladding systems facilitate the development of energy efficient buildings; that levels of material recycling and/or re-use are high and that the use of off-site manufacture promotes safer working, stability in the workforce, and skills development, whilst at the same time minimising the impacts of site construction. The strategy does however recognise that more needs to be done and sets out a plan to achieve this, and sets out the following eight guiding principles for sustainable construction:

- Understand what sustainable development means for you, your clients and customers.
- Use whole-life thinking, best value considerations and high quality information to inform your decision making.
- Design for flexibility to extend building lifetimes, and, where possible, further extend the life of buildings by renovation and refurbishment.
- Design and construct with maximum speed and minimum disruption around the site.
- Design to minimise operational impacts (eg energy use).
- Design for demountability, to encourage future re-use and recycling of products and materials.
- Engage organisations within your supply chain about sustainable development.

- Select responsible contractors who have embraced sustainable development principles.

3 Understanding Sustainable Development

Sustainable development encompasses complex and wide-ranging issues. There are often conflicting indicators – decisions which may support one element of sustainability can be detrimental to another – and it is important to consider the balance of all impacts – social, environmental and economic. A classic example of where it can be difficult to balance impacts occurs when deciding whether it is more sustainable to build a naturally-ventilated office building on a greenfield, rural site or an air-conditioned building in an inner city location. The answer could be either. It will depend on the balance of a number of issues such as the implications of greenfield as opposed to brownfield development, operational energy consumption, transport arrangements for occupiers etc.

The steel sector has produced a number of guides which can be helpful in this respect, and has conducted a survey to determine the attitude of clients and their advisers to the issue of sustainable development. The results of the survey showed that design briefs from public sector clients are increasingly reflecting government sustainable development policy, and that, whilst the private sector is still often driven by lowest cost, growing consideration is being given to other issues such as whole-life costing, health & safety, and business probity. Speed and predictability of construction remain high priorities, and flexible buildings capable of accommodating change are valued. There is an increasing appreciation of the need to consider end-of-life issues, where the ability to re-use components and recycle material is important, and clients are responding to stakeholder pressure for socially responsible behaviour.

4 Informed Decision Making and Whole Life Considerations

Decisions on sustainable design and construction should be based on a consideration of their implications across the full lifetime of the building. To make the 'best' decision, the designer must be in possession of high quality, robust and credible information, and consider the impacts throughout the expected life of the building. This generally means carrying out a Life Cycle Assessment (LCA). Life Cycle Assessment studies the environmental aspects and potential impacts from 'cradle to grave', ie from raw material acquisition through production, use and disposal. As well as being a vital tool in considering whole life issues, LCA can be used to identify environmental hotspots in the life cycle of a 'product' and as a basis for comparing alternative solutions.

Undertaking an LCA in the construction sector is a not a simple process. A modern multi-storey building comprises thousands of components and hundreds of different types of materials. Evaluation is therefore highly complex.

A number of organisations have developed software tools to help in this process and to support informed decision making in design and construction. These typically assess the performance of buildings across a range of areas such as management, energy use, health, pollution, transport, land use, ecology, materials and water use. These are then weighted to give an overall 'score'.



At the time of construction, the Wessex Water Operations Centre near Bath achieved the highest score recorded using the BREEAM assessment method developed by the Building Research Establishment. Built on a brownfield site close to an area of outstanding natural beauty, the building uses a steel frame with bespoke concrete coffered slabs across which natural cross ventilation from high level windows is channeled to allow heat exchange between the air and concrete for night time cooling. Effective use of solar shading also acts to maintain comfortable temperatures. A good working environment is created by optimising the quality of natural light throughout the building. The building is designed to use less than a third of the energy per unit area of a conventional, air-conditioned office.

Such an approach concentrates on the environmental impacts of construction. To be truly sustainable, design must also emphasise the economic and social aspects.

In summary, there is a need to consider and balance all impacts across the full life of the building. This can be achieved partly by using a Life Cycle Assessment, using reliable methods and data, but may need to be complemented by considerations of social and economic impacts.

5 Design for Long Life and Low Maintenance

The use to which a building is subjected can change many times over its lifetime, and if these cannot be accommodated easily, demolition and rebuilding may be necessary. This is clearly wasteful. Buildings which can accommodate changes to the functions for which they were originally conceived can therefore contribute

significantly to sustainable development. Useful life can be extended by adapting internal spaces, structural extension and upgrading of the external envelope. This facilitates reductions in life cycle costs and lifetime impacts and encourages extraction of increased value from available resources. Extending building life also has the effect of preserving cultural and historic value.

Long span construction in particular can create flexible spaces which facilitate changes in use and service requirements; this can maximise letting potential and reduce refit costs. Flexible buildings which can accommodate changes in use, increase lettable area and maintain asset value are highly valued by clients. The high strength-to-weight ratio of structural steel makes it ideal for long span floor and roof systems

Repair and maintenance can add considerably to the total burden during the life of a building, but are essential to achieve longevity. Steel construction products require relatively little maintenance, generally only where the steel is exposed to an external or corrosive atmosphere, or for cosmetic reasons. A wide range of coatings is available which, when used in accordance with a suitable inspection and maintenance programme, will give excellent long term protection.

Refurbishment can also extend the useful life of existing buildings, contributing to sustainable development and often helping to preserve cultural and historical heritage. The versatility, strength and flexibility of steel enable such work to be undertaken with minimum disruption.

In summary:

- Designing buildings so that they are adaptable and flexible can extend their useful life. A key issue is to provide long span floor and roof systems, creating wide column-free spaces.
- Where steel is exposed, suitable surface protection should be provided, and an inspection/maintenance programme adopted.
- Refurbishment should be considered as an alternative to demolition and new build.

6 Speed and Efficiency of Construction

Speed, efficiency and accuracy of construction are high priorities in construction, saving money and reducing local impacts associated with building work. For busy, congested urban development where land values are high, rapid construction is essential.

Computer based design and information management systems allied to significant improvements in erection techniques have collectively led to great improvements in logistics and planning, enabling rapid and reliable

steel construction. Increased prefabrication, extending to modular construction is also having a considerable impact on building construction efficiency. Factory working facilitates accurate and high quality workmanship which has a considerable impact on speed and efficiency of on-site construction.



The socio-economic aspects of sustainable construction featured highly on the TNT FastTrack project at Lutterworth, where the steelwork contractor, Barrett Steel Buildings Ltd, paid exemplary attention to health and safety without compromising a rapid speed of erection. This project also won a Structural Steel Design Award for its design quality and further details are given in the case studies chapter of this book.

7 Efficient Operation

The energy associated with the occupation and use of buildings can dominate that used in manufacture and construction by as much as 10:1 over a 60 year design life in a high usage building incorporating a modern air-conditioning system. Even for a naturally ventilated office building with a 30 year life span the operational to construction energy ratio is typically 3:1. Reducing operational energy consumption in buildings reduces environmental and financial impacts and generally has a greater impact than reducing the burdens associated with construction.

In commercial offices, cooling is usually the most significant user of energy. Fabric energy storage, ideally used in conjunction with natural ventilation, can be utilised to reduce or even eliminate the need for air conditioning. This typically takes advantage of the exposed surfaces of composite or other types of floor slab and is readily accommodated in typical steel framed construction.

In residential buildings energy is more likely to be wasted as a result of heat loss in cold weather. High levels of insulation and a well sealed envelope help to minimise such losses, and panellised cladding systems can provide an efficient solution.

Natural lighting, with good levels of external glazing, appropriately shaded to avoid glare and excessive solar gain, can also contribute significant savings.

Building efficiency is not restricted to reducing energy consumption, but extends to improved working conditions. Over the lifetime of a commercial building, the ratio of the value of the work performed within to that of operational energy and the building construction can be as high as 200:10:1. Consequently, creating an internal environment conducive to efficient working is a key principle of meeting the objectives of sustainable development. This can be accomplished by designing buildings which are comfortable, attractive and admired.



Baglan Energy Park was built on reclaimed industrial land, this air-tight, steel-framed and steel-clad building was constructed using local steelwork contractors.

In summary:

- Over the typical lifetime of a high use building, operational energy is much greater than the energy associated with construction.
- One of the major issues is to minimise cooling requirements, provide high levels of natural lighting whilst avoiding direct sunlight, and minimising heat losses.
- The balance between these depends on the nature of the building occupancy.
- Providing a comfortable internal atmosphere which encourages good productivity can be even more important in terms of economic value.

8 Recycling and Re-use

Design for recycling and re-use can significantly reduce the environmental burdens in construction. As a general rule, re-use (of complete buildings or individual

components) represents the greatest value, but recycling is easier.

Recycling should not be confused with downcycling. The former implies the ability to repeatedly return a component to its original state with no loss of quality; downcycling implies some reduction in quality or value and this can limit the number of times a product or material can realistically be reprocessed. Specification of materials which can be recycled clearly has the greater benefit to sustainable construction.

Steel is the world's most recycled material. Of the world's total production, almost half is recycled from scrap. Indeed, steel is unique amongst construction materials in that it always contains some recycled content. Nevertheless, the long life of modern steel components, coupled with global expansion, means that aggregate demand cannot be met from available scrap supplies. This makes it necessary to use steel from primary ore to supplement the production of new steel.

In addition, steel does not rely on the specification of recycled scrap content to drive demand. An extensive world-wide infrastructure for recycling steel has been in existence for over 100 years and over 80% of scrap arising is captured.

In summary, providing that the steel is recycled in future, virgin steel today can be regarded as an investment into efficient resource use for the future. In the UK, recovery rates for steel components from building demolition sites are 84% for recycling and 10% for re-use.



From an environmental and commercial point of view, re-use of steel offers more benefits than recycling as it conserves the added value invested during the production process. This is best seen in the market for second hand piling. Contractors regularly re-use from temporary works but they have also found that piles recovered from the ground after many years use in permanent structures are suitable for re-use as the foundations in new projects.

9 Supply Chain Engagement

No sector of the construction industry can move the sustainability agenda very far in isolation. Economic growth, community and workforce involvement, environmental protection and resource use all involve a complex web of interactions between commercial organisations. Sustainability demands a change in emphasis, not towards abandonment of profit as an

essential measure of success, but a shift in focus towards looking at business as part of the whole interdependent economic, social and environmental system.

One of the problems of construction however, is the nature of the industry, which is typified by a relatively small number of large organisations and a large number of small organisations. To many of the latter, sustainability may be seen as an add-on cost in the struggle for survival. There is an onus on the larger organisations in particular to drive the sustainability agenda by adopting sustainable practices and by insisting that their suppliers and contractors meet their own standards of environmental reporting, social responsibility and skills retention.

CHAPTER 22

Building Envelope

By Alan Scupham and David St Quinton, Ward Building Components Ltd

1 Introduction

On modern industrial buildings the building envelope is made up of the outer weather barrier, thermal insulation and an inner liner. These components are attached to structural members that support the applied loads and transmit them through the main frame to the foundations. The following chapter contains an introduction to building envelope design and the key issues involved. For more detailed information the reader is advised to consult the references to this chapter.

When designing the envelope the key points to consider are:

- The proposed design and application
- Weatherproofing
- Thermal performance
- Fire protection
- Structural support
- Roof drainage
- Durability

Whilst every effort has been made to ensure the information in this article is correct Ward Building Components Ltd accepts no responsibility for any errors or inaccuracies.

2 The Proposed Design and Application

2.1 Design Objectives

It is essential when considering the design of the building envelope that the fundamental client demands are satisfied. The choice of the materials and quality of the as-built construction should be such that it will meet the aesthetic requirements, perform all critical functions effectively and be constructed to schedule and within budget.

The envelope design must pay detailed attention to the technical performance of the system with respect to weather, structural and thermal resistance, current Building and Fire Regulations and the practical aspects of site construction and safety.

The design team must consider all the above design requirements while ensuring that the envelope will provide long term integrity with minimum maintenance.



2.2 Construction Concepts

There are essentially two insulating concepts for the profiled metal building envelope:

- Site built-up twin skin systems; or
- Composite panel systems.

Built-up systems consist of separate components: outer sheet, insulation, spacers, vapour control layer and internal liner which are assembled on site. Composite systems are supplied as pre-engineered one-piece panels. The built up option is less rigid than the composite so tends to be more suitable for curved roofs. Better acoustic performance is possible with a twin skin system so these products are more often specified on cinemas, schools etc.

Where acoustics or curving is of no significance composite panels have the advantage of quicker installation and guaranteed thermal performances. Composites tend to be used on common 'shed' designs such as warehouses and distribution centres.

In terms of overall weight imposed on the structure the most common construction types show little difference, however thickness of the overall construction (for the same U value) is significantly less with composite panels.

3 Weatherproofing

3.1 Environmental Separation

The basic function of the building envelope is to provide the necessary degree of interior and exterior environmental separation to protect the occupants. Weatherproofing is central to this design objective and cladding systems must

respond to the demands with waterproof materials and weatherproof jointing systems. This is particularly true of roofing systems where exposure is severe and presents greater potential for leaks. Risk is minimised by reducing the number of potential weak points such as end lap junctions while ensuring reliable weather seals are easily formed where required.

3.2 Traditional Through-Fixed Systems

Roof pitch plays an important role in this process and system design dictates a change to more specialised systems as the pitch of the roof reduces. At a roof slope above a nominal 6 degrees, traditional through-fixed constructions may be used to good effect. Weatherproof performance of such systems relies on the butyl mastic seals forming the end and sidelap joints, along with reliable performance of the fasteners and their sealing washers. Frequency of fasteners to ensure compression of the weather seal and correct number and shape and positioning of the seals is critical, and manufacturer's recommendations must be closely adhered to ensure the best possible performance.

3.3 Concealed Fastener and Standing Seam Systems

Pitches less than 4 degrees force a change of design and concealed fastened or "standing seam" systems are needed to ensure integrity. These systems are frequently fastened to the steel supporting structure by means of clips. In some cases the unique fixing methods used to eliminate the through-fastening will require consideration of the amount of structural restraint provided to the supporting structure. Thicker or stiffer liner tray profiles may be needed with these systems compared with the normal twin skin through-fixed system. Butyl seals are needed to seal between the end and side laps of panels. These are applied as a continuous run to prevent moisture entering the cavity.



4 Thermal Performance

4.1 Regulatory Requirements

The recent revision to Part L2 of the Building Regulations has led to significant changes to envelope design. World-wide concern over climate change and the impact of greenhouse gas emissions on the environment have encouraged governments to act. Buildings are major energy users and therefore construction is a targeted area for change across Europe and the UK.

The principal amendments that came into force 1 April 2002 include:

- Increased levels of thermal insulation.
- Calculation requirements to assess condensation risk and the impact of thermal bridging.
- Provision for effective insulation continuity.
- Introduction of a strict criterion for maximum air leakage for all non-domestic buildings over 1000 sq m, including the need to measure this using air pressurisation testing.

4.2 U Values

The amount of heat transmitted through the envelope per unit area per degree of temperature is termed "thermal transmittance", and it is called the U value of the envelope. Changes to thermal regulations have resulted in a reduction in the U value for the cladding elements, effectively doubling the thickness of insulation required. U values are given in the manufacturers' information and are required to be less than or equal to 0.35 W/sq m K for walls and 0.25 W/sq m K for roofs.

These requirements are for the assembled envelope and are "averaged" across areas of plain cladding, windows and local details such as where the design dictates that metal penetrates the insulation. These latter paths can conduct significant amounts of heat as "thermal bridges". The regulations introduce the need to take account of these thermal bridges around openings and through junctions. The envelope should be designed and installed such that there are no significant thermal bridges or gaps in the insulating layers due to the junction details.

It is necessary to consider both the risk of condensation on each individual thermal bridge and the effect of heat loss as a contribution to the total heat loss from the building. All cladding systems in practice incorporate these details and the varied nature of the systems used means that robust details with specific thermal values are specific to each individual manufacturer's system. Qualifying thermal details that can be reliably installed are termed "robust" details.

All manufacturers' robust details are evaluated with a 'psi' value. This is a measure of the additional heat lost due to thermal bridging. The magnitude of the value reflects the amount of thermal bridging that exists. For example a value in the region of 1.5 W/K per linear metre represents a significant heat loss.

In practical terms each building has different details and varied numbers, the overall impact of these details are evaluated by equating the Alpha value of the envelope. MCRMA Technical Paper 14 "Guidance for the design of metal roofing and cladding systems to comply with approved document L2:2001" outlines the detailed calculation methods required.

4.3 Air Leakage

Air leakage accounts for over 50% of heat loss from the building and when properly controlled can provide significant benefits in running costs in addition to meeting the regulatory requirements. Evaluation of the air leakage performance provides a good indication of the supervision and care taken in construction of the envelope. Good performance is a function of the type and positioning of the sealing elements and the accuracy of the supporting steel substructure in integrating with the roofing and cladding elements.

Testing involves large fans imposing an internal pressure within the building. The quantity of air moving through the fan is known as is the imposed pressure difference on the building envelope. From this the air leakage rate can be found and a standard of performance stated for the building.

Criteria that demand an integrated performance from structure and envelope mean that now, more than ever, commercial and industrial buildings will be required to be designed and constructed as a whole. The external envelope requires a single point of responsibility for the design, detailing, supervision and installation rather than being treated as merely an assembly of separately-sourced individual building elements. Prefabrication of components and systems are essential to ensure success on site.

5 Fire Performance

Fire performance has become an important area recently following large losses primarily in the food processing industry where there was experience with the cores of cladding panels contributing to fire spread. Insurers have begun to take more interest in fire safety management including the composition of the building

envelope. In May 2003 the Association of British Insurers [ABI] issued a technical briefing document: Fire Performance of Sandwich Panel Systems.

When designing envelopes it is important to be aware that not all panels have the same fire performance. Those with a polystyrene core are combustible and should not be used in high-risk areas. Polyisocyanurate (PIR) cores do not contribute to the spread of fire and can be used in most situations. These have normally passed the Loss Prevention Council tests and carry the LPC mark. For high-risk areas such as protected zones or boundary walls a non-combustible core should be specified.

6 Structural Support

6.1 Load Cases

All roof and wall sheeting and panels must be strong enough to withstand the worst combinations of wind, snow, imposed and dead loads calculated. The load cases to consider in accordance with British Standards are generally:

Load Case	Factored Loads
Dead + Imposed	1.4Wd + 1.6Wi
Dead + Snow Drift	1.4Wd + 1.05Wsnow
Dead + Wind	1.4Wd + 1.4 Wind
Dead – Wind (ie uplift)	1.0Wd – 1.4 Wind
Attachment	1.0Wd – 2.0Wind

Notes

Wd = Dead Load (see BS 6399-1)

Wi = Imposed Load (see BS 6399-1)

Wsnow = Snow Drift Load (see BS 6399-3)

Wind = Wind Load (see BS 6399-2)

"Attachment" refers to the fixing assemblies (fasteners or clips). As uplift from wind suction is the critical case, a minimum factor of 2 should be applied to Wind, and this may need to be increased when attaching to timber or other non-steel substrates.

Construction point loading can be a critical load case for twin skin systems. Foot traffic load on the outer skin can cause buckling of the profile possibly damaging the coating and the load bearing integrity. Minimum thickness to resist foot traffic damage is generally 0.7 mm for a typical steel profile sheet, however performance is also related to profile geometry and manufacturers' recommendations should always be checked. Metal roof cladding is normally only designed for cleaning and maintenance loading and if regular access is required special walkways should be provided.

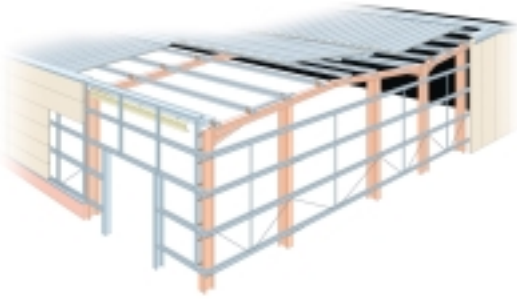

6.2 Construction Details

Profiled metal sheet and panel manufacturers all provide load span tables to enable the building designer to select a suitable spacing for the supporting purlins or rails. Typical spacings are 1.8 to 2.0 metres for purlins and 2.0 to 2.5m for side rails dependent on the cladding types used.

Spacer systems must be strong enough to transfer all loads acting on the outer weathersheet into the building structure, whilst maintaining the cavity for the insulation. There should not be excessive deflection particularly under foot traffic loads. Each spacer system will have differing fixing arrangements but in all cases there must be sufficient fasteners to resist the applied loads. Wind suction is often the critical load case. Note that the pull-out strength of a fastener depends on the thickness and grade of material to which it is fixed. A minimum steel thickness of 1.3mm in steel with a minimum yield of 350 MPa is recommended.

Calculation of wind and snow loading requires detailed consideration and can be a lengthy process. When designing the cladding it is essential to consider the higher loads imposed in local areas of the roof and wall. Concentrated wind loading is critical at the corners, eaves and verge, whereas local snow load due to drifting occurs behind obstructions such as parapets and in valleys. Software packages offered by the purlin manufacturers are of considerable help in evaluating the loading imposed.

6.3 Purlin Restraint

When fixed correctly, profiled metal roof cladding systems assist in the design of the framework by providing a measure of restraint to the top flange of the purlin. Safe working loads for purlins are based on the assumption that the sheet profile and fastener system employed will provide full lateral restraint.

Purlin design requires that the cladding system provides restraint to the purlin through the top flange being fixed to the cladding with suitable self-drill self-tapping screws at adequate centres – generally 4 or 5 screws spaced across 1.0m cover

width or equivalent. Where the cladding cannot provide this restraint (as occurs with some standing seams, large areas of roof lights, or tiled roofs without robust liner trays) then additional sag rods are required or a reduction in the purlin load-carrying capacities will be necessary.

Sag rods between purlins are provided to restrain the section in the span when the loading is reversed by wind suction and the bottom flange is in compression. With the advent of BS 6399-2 some roofs have far more substantial areas under very low wind uplift loads so that even on quite large spans secondary restraints may not now be needed to ensure the purlin's structural performance in the as-built condition. In these case (large spans with low wind loads and no restraints) it may be that the stability of the purlins during the cladding phase, where the need to support cladding packs and personnel access for the cladding fixers, should be considered either in the form of temporary restraint provided as part of the cladding process or the provision of secondary restraints as part of the system.

Perforated liner sheets used in acoustic absorption constructions may not be strong enough to provide sufficient restraint, depending on metal thickness, profile and the perforation pattern. Each use should be considered carefully.

It is the responsibility of the cladding contractor to ensure that the correct fastener system is used as recommended by the cladding or fastener manufacturer.

7 Roof Drainage

The roof drainage system is an important aspect of the overall roof design. This is particularly true for parapet and valley gutters, which are inside the building line and are effectively part of the roof. Any overflow into the building would be unacceptable. Eaves gutters are outside the building and their design is less critical.

The design procedure is complex and based on gutter size and arrangement, rainfall and catchment area. Further details are available in BS EN 12056-3 which replaces BS 6367.

Internal gutters will require insulation and need to be sealed to prevent heat loss and condensation. Note however that insulating to the same standard as the roof might prevent accumulations of snow from melting quickly and could result in a blockage.

As gutters are often subject to corrosive conditions because of standing water and debris their selection requires careful consideration.

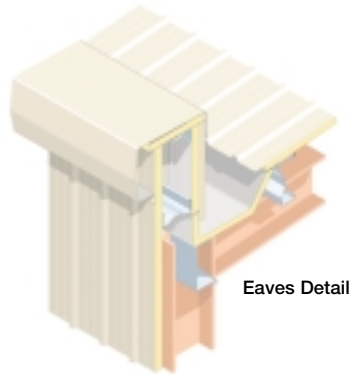

8 Durability

8.1 Atmospheric Effects

Virtually all materials will change physically when subjected to UV radiation, moisture and atmospheric pollution, with a resulting effect on their performance. The type of sheeting material, coating and colour must all be considered. The performance might also depend on the shape and orientation of the building and the environment. Generally light-coloured coatings are preferable because they do not absorb as much sunlight as darker colours and are therefore cooler. This means that they tend to have a longer life and improve the thermal performance of the roof.

8.2 Maintenance

The minimum period to repaint of the coated sheets will depend on the roof pitch, type of coating and proximity to coastal areas. Typically this can be anywhere between 10 and 30 years.

Most metal profiles are manufactured with a wide range of profiles and finishes. The profiles or panels can be used to provide diversity of architectural expression by being horizontally or vertically fixed. There has been a long experience of using the main generic coatings of PVC plastisol and PVF2, and these provide the designer with practical and durable coatings in a wide choice of colours.

The coating life is always dependent on regular maintenance. This will involve inspection, removal of debris, cleaning and repair of any damage found. Gutters are likely to require the most frequent attention since debris tends to accumulate in them and restrict capacity, whilst increasing the potential for corrosion.

Case Studies



The Structural Steel Design Awards Scheme

Corus Group plc, The British Constructional Steelwork Association Ltd and The Steel Construction Institute, are Sponsors of the Structural Steel Design Awards Scheme.

The objective is to celebrate the excellence of the United Kingdom in the field of steel construction, particularly demonstrating its potential in terms of efficiency, cost effectiveness, aesthetics and innovation.

The judging panel selects award winners after assessing all entrants against the following criteria:

Planning and Architecture

- Satisfaction of client's brief, particularly cost effectiveness
- Environmental impact
- Architectural excellence
- Durability
- Adaptability for changing requirements through its life
- Efficiency of the use and provision of services
- Conservation of energy

Structural Engineering

- Benefits achieved by using steel construction
- Efficiency of design, fabrication and erection
- Skill and workmanship
- Integration of structure and services to meet architectural requirements
- Efficiency and effectiveness of fire and corrosion protection
- Innovation of design, build and manufacturing techniques

The following pages illustrate the last three years award-winning building projects undertaken by BCSA members.

City of Manchester Stadium

Manchester has a new iconic symbol for the city. It was completed in March 2002 as the centrepiece of the hugely successful XVII Commonwealth Games. The stadium was constructed on a derelict site and will act as a catalyst for the redevelopment of the surrounding area.

It is an example of a building whose architecture and structure has not only captured the imagination of those who use it but will bring long term benefits to the residents of both the surrounding area and the city as a whole.

The Stadium structure utilises a mixture of structural systems. In-situ and precast concrete were used to construct the stadium bowl and structural steel supported from a cable-net of masts and steel cables to form the roof.

The City of Manchester Stadium is a remarkable structure due to several key features:

- It is one of the most cost effective quality stadia of its size in Europe. Typical examples of multi-function components of the building are:
 - The stadium is circular to provide optimum views for spectators. It sweeps up from low sides on the North and South elevations that allow sun on to the grassed area, to high sides on the East and West giving protection from prevailing winds and low sun angles.
 - Roof Structural Liner Tray - these 150 deep aluminium panels act structurally to support the roof sheeting as well as creating a hidden zone for acoustic insulation, wiring and roof bracing. The trays also form a visually clean ceiling to the roof that would not usually be economically viable on aesthetic grounds alone.
 - Concrete Ramp Towers - the eight concrete towers to the east and west of the stadium serve three distinct purposes. Firstly they support the spiral ramps that provide access and egress for spectators. Secondly the spaces within the concrete ramp drums are utilised for plant as well as toilet facilities. Finally they provide an elevated support for eight of the 12 roof masts.
 - The stadium is unique in Europe as a building of two distinct lives - initially a 41,000 seat athletics stadium and then to be permanently converted into a 48,000 seat football stadium (completion Summer 2003). The construction flexibility is central to the success of this transformation. The primary roof support structure that consists of a pre-stressed mast and cable-net system is independent of the roof-plane rafters and purlins. This allowed the roof to be added below the cable-net in whatever sequence was required.

The innovative mast and cable-net roof primary structure utilises a 'grounded tension ring' in order to create a prestress field against uplift wind loads. The structure comprises 12 cigar-shaped tubular steel masts up to 65 metres high. Eight of the masts sit on cone shaped tubular supports on top of the spiral concrete ramps at the East and West sides. The masts support 76 spiral strand forestay cables in fan-shaped groups of five or seven cables per mast. Each forestay supports an individual roof rafter. Just above the roof surface all forestay ends are connected by a system of four spiral strand cables that form the grounded tension ring (also referred to as the 'catenary'). Prestress to the catenary and cable-net is provided by the four corner-ties anchored to the ground. The top of each column is tied back to the ground by pairs of backstays comprising groups of 'Macalloy' high tensile steel rods.

The erection scheme provided the greatest challenge for the team. The rafters, masts and pyramid supports were fabricated in transportable sections and then welded at site into complete elements. After carrying out risk assessments on the erection scheme it was decided to construct the rafters on temporary props generally supported on the concrete terrace. This allowed the construction of other elements to proceed at the same time without the constraints of sequence. If the masts and cables had been erected first, to provide support for rafters, any delay to the critical cable assembly would have a corresponding delay to the remaining work.

The catenary cables were assembled at ground level in the bowl of the stadium, on jigs which supported the nodes in the correct geometry. After clamping the four cables at the node points, the complete assembly was lifted on top of the rafters and supported on temporary works.

In conjunction with the above, masts were erected and made stable by the permanent backstays and temporary forestays connected to the temporary props supporting the rafters. At this stage the masts were positioned one degree forward of their pre-set geometry to facilitate fixing the permanent forestay cables.

The corner ties to the completed catenary were erected, connected to the catenary, and a pre-tension of 200KN applied. The permanent forestays from mast to catenary were fixed using a predetermined sequence that ensured the catenary displacements were within acceptable limits.

The final tensioning of the cable net could now commence - the basic sequence being to increase the corner tie tension to 1000KN simultaneously at each corner using temporary hollow jacks on the ends of the cables. This was followed by releasing the temporary

forestays whilst at the same time adjusting the permanent backstays to maintain a minimum tension. When the majority of the load had transferred from the temporary forestays into the catenary the forestays were then released. Once all the forestays were released final tensioning commenced. Firstly all the backstays to the masts were jacked to length, all four pairs simultaneously, and the pins inserted into the anchorages. After all the backstays were complete the final tensioning of the corner ties commenced simultaneously increasing the tension to 2550KN. The final activity was to jack up the rafters from their supports install its linking member to the catenary node and remove the props.

In summary the structural solution for the stadium has produced a design that not only adds significantly to the overall stadium architecture but is one of the best value-for-money stadia of its size in Europe.

It is a demonstration of overall building design, which can be attributed as much to the engineering and construction as to the architect.



New Hangars for TAG Farnborough Airport

Part of the £45m redevelopment of TAG Farnborough Airport, which also includes a 35m high air traffic control tower and brand new terminal, the £9m three bay hangar is 290m long, 45m deep and 22m high at the apex and large enough to accommodate six Boeing 737s.

TAG Farnborough has a vision for the airport and seeks to differentiate themselves from other service providers in this field through the design and quality of the facilities it provides. The challenge set for the design and construction team of REID Architecture, Buro Happold and Bovis Lend Lease was to accommodate the functional requirements with a design aesthetic that reflects the qualities of the TAG brand image and yet without a cost premium over the more conventional design and build 'shoe box' hangars.

The design team appreciated that they had to adopt a radical 'back to first principles' approach to meet this challenge and develop a design that was ultra efficient. As with most buildings, a very significant component of cost is the cladding - it was essential to reduce the area of the elevations as much as possible. The added benefit of reducing the volume of the building and minimising the clad elevations is improved aesthetics, reduced wind load on the structure and a reduced impact on the surroundings.

Various structural systems were explored with the arch proving to be the most efficient. The arch followed the natural profile of the plane geometry, ie maximum headroom where the tail fin is and reduced at the wing tips. From a structural point of view an arch is a very efficient structural system acting largely in pure compression minimising bending and deflection. Traditionally the arch reactions are resisted by either using thrust blocks, which would have been large and expensive, or by installing a tie between the arch ends. More usually in a tied arch of this type the tie is placed above the minimum level of the plane increasing the overall height of the building. To avoid raising the structure, the arch form was extended to ground level through the use of inclined "A" frames in the form of concrete filled tubes. In this way the tie could be placed underground in the form of prestressed reinforced concrete beam. By introducing roller doors in tail fin slots in the gable end of the hangar the elevation could be reduced further. Fit out of accommodation within the hangar envelope can then take place with offices and workshop accommodation located around the support legs, rather than in 'bolt on' accommodation at the back or sides of the hangar as is more normally the case.

A key concern in the design was the bending induced in the arch through asymmetric loading. Bending resistance was introduced by forming the arch from a trussed arch 3m deep formed from rectangular hollow section chords and square hollow section lacing. The trusses are spaced 9m and span 90m. Secondary trusses link the trusses together and reduce the buckling length of the chords. Each of the trusses is connected to "A" framed support via a pin. The "A" framed legs are made up of concrete filled circular hollow section legs and a headpiece fabricated from 80mm steel plate. Two wind trusses spanning 90m achieve lateral stability. To gain a detailed understanding of how the structure is behaving it was modelled as a three-dimensional non-linear model.

By working closely with the steelwork contractor an erection procedure was established which proved both simple, cost effective and reliable. Each 90m truss was split into three segments. A double bay was assembled on the ground comprising two truss segments linked with all connecting secondary trusses and purlins. These segments would then be lifted in place and jointed in the air. After an initial learning curve and some refinements this method proved very successful. The hangar steel was erected on programme.

The hangar construction commenced with ground works in October/November 2001. Steelwork erection started January/February 2002. The main hangar was completed in November/December 2002 with additional office space being added until April 2003. A total of 823t of structural steel (63 kg/m²) and approximately 100t of cold rolled steel was used in this hangar.

This project has been a good example of what can be achieved by close co-operation between the client, the design team and the specialist contractors and how creative design can achieve a result that completely satisfies the client's aspirations at a cost of no more than conventional solutions and yet lifts the spirits and is a positive addition to our built environment.

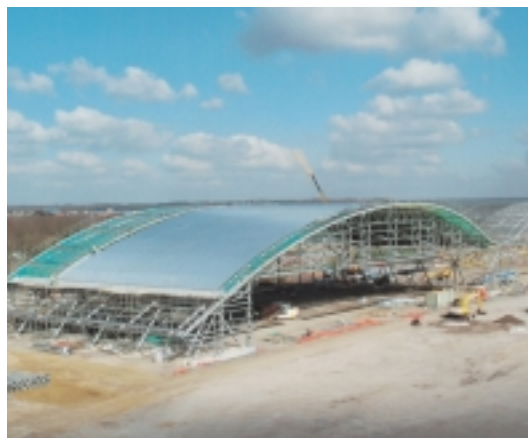



Millennium Point, Birmingham

Sustainability and the care of our natural environment are increasingly important considerations of the construction industry and ones that are now affecting the choice of materials, building systems and the management of construction. The design of Millennium Point attempts to address one of the more environmentally significant aspects of the industry. It does this by reducing the need for wasteful demolition and rebuilding whilst meeting the changing needs of occupiers and new technology.

The structural system developed for this building offers the fit out and servicing advantages of traditional flat slabs. However, in addition, it greatly enhances the longevity of the structure by adding the ability for the form of the floors to be changed, without costly and intrusive strengthening or demolition works.

Millennium Point is an example of an enormous building, designed to be truly flexible and adaptable, as well as durable and quick to build.

Millennium Point, the millennial landmark project for the Midlands, opened to the public on 29 September 2001. The development covers a site the size of six international soccer pitches, and is the catalyst for the regeneration of the east side of Birmingham city centre.

From the start of the project, an essential aspect of the brief to the design team was to create a high quality modern building: one that expressed the engineering heritage of the region, and where the structural and mechanical functions are clearly expressed. This was a deliberate intention, in order to allow the building itself to be perceived as part of the exhibition of, and investigation into, technology.

The different requirements of the component facilities within Millennium Point led to the design of a truly flexible, adaptable building, a building that allowed for the creative museology of Thinktank, and the changing needs of exhibition, retail and education facilities.

Working together, the design team developed a solution that will allow creative accommodation for any number of different uses in the years to come. An expressed composite steel frame supports reinforced concrete floor slabs that were cast on a pre-cast concrete permanent formwork system. The supply air, electrical and IT cabling are distributed within a deep raised floor and the lighting and air extraction systems are suspended from the exposed structural slab soffits. This holistic approach, expressing the structure and building services as part of the architecture, maximised repetition in the implementation of the building elements, allowing the structure to be prefabricated and assembled quickly, almost as a kit of parts, on site. The exposed integrated design solution allows both the construction and the working of the building to be easily understood by visitors: effectively the building itself has become part of the educational experience of Millennium Point.

Apart from being an integral part of the building's architectural and environmental strategy, the structural frame was designed not only to be adaptable, but also to be both durable and fast to build. It was quickly realised that a form of flat slab construction would best suit the many and varied uses planned to meet the vision for the building, and that flat slab construction would also allow the unhindered transverse distribution of services. However, a problem soon arose as detail design proved that a conventional reinforced concrete flat slab structure would become uneconomically heavy if it was placed on a 9m grid. This form of construction also posed problems with the quality control of the exposed slab soffits. Furthermore due to the heavy level of reinforcement, which would be required, particularly around the columns, only minor openings could be cut into the concrete slabs to allow for the installation of future services and building alterations. This conventional solution would have severely impeded the desired flexible nature of the internal structure.

To overcome these disadvantages, whilst retaining the advantages of the flat soffit and overall shallow structural depth, a composite structural steel and reinforced concrete hybrid frame was developed. This hybrid structure basically concentrates the reinforcement into discrete lines of structural steel, spanning between the columns and a cross head of structural steel, bringing the floor loads into the columns. While the bottom flanges of the steelwork are exposed, expressing the grid pattern of the floor structure in the slab soffit, the beams are embedded within the concrete slabs, dealing effectively with the appropriate fire rating requirements. The floor beams are set out on a standard 3m by 6m grid in both directions, with 3m square cross head details connecting the grid to the columns. The system allows considerable flexibility in the configuration of the building. Any of the concrete slab sections that fill in between the steel beams can be removed, as can the triangular pieces around the columns to allow space for service risers. The 3m by 6m strips between the columns provide the capability to accommodate any future need for the installation of stairs, allowing 1.5m for each flight and a 1.5m deep landing at each end. Most dramatically, the central 6m by 6m soffit section between the steel columns can be removed, to provide a double height space for specific exhibitions or equipment.

Furthermore, the exposed bottom flanges of the beams offer a regular pattern of fixing points from which to suspend displays or exhibits, without damaging the aesthetic of the finished precast concrete slabs.

Continuing the theme of integral fire rating, the columns are constructed from composite structural steel that has been filled with reinforced concrete. Designed in accordance with Eurocode 4 part 2, the

slender columns, with a 457mm diameter, achieve the fire rating required while eliminating the costly and time-consuming application of any additional fire protection. The columns came to the Millennium Point site fully primed, only needing top coats of paint to be applied on site. This fast track approach has produced a durable column finish that is both easy and cost effective to apply and maintain.

The various sections of Millennium Point's frame were prefabricated off site, and then delivered and erected systematically alongside the installation of the precast concrete. Once the frame was lined and levelled the concrete topping was put in place.

The design of the structural steel frame gave specific focus to ensuring the maximum use of prefabricated components. All of the elements that make up the structural steel frame - columns, cross heads and beams - were carefully designed so that they could be manufactured into distinct modular sections with simple bolted connections to ensure rapid, easy assembly on site. The concrete filling of the columns and floor topping work compositely with the steelwork and finally lock the different sections of the frame together. This approach, together with the introduction of the precast concrete floor, ensured a very high quality building, while also enabling a very quick erection process on site. Logistically, the design approach allowed the construction of the frame to advance well ahead of the following trades, minimising the disruption of a congested busy building site.



TNT FastTrack, Magna Park, Lutterworth

TNT UK Ltd urgently required a large distribution facility for their subsidiary TNT Retail Services to service Primark, the fashion retailer trading from 103 high street locations in the UK. TNT were convinced that fitting out an existing building would be the only option open to them. The ideal solution would be a bespoke facility, an option now available to clients through FastTrack.

FastTrack is the name of Gazeley Properties' new concept in distribution developments – a fully operational facility in 10-12 weeks. The TNT project demanded a 412,000 sq ft facility to be operational in 12 weeks. 40 weeks is a typical build programme for a bespoke building of this size.

The project

- Design and build a 1600 tonne steel framed distribution facility.
- Three and a half week erection programme, compared to a normal 15-week programme.
- The project's success rested on the steelwork contractor's ability to meet this programme. Follow-on trades required carefully phased handovers – the first after just four days, to start cladding.
- Steel – the only material capable of meeting such a demanding programme.
- "Speed engineer" to maximise on-site production; a shift from traditional minimum weight design.
 - reconfigure the building layout, span frames to maximise the working fronts during erection.
 - rationalise the number of cold rolled items, they require the most restraint by ancillary items and slow down erection progress.
 - robust members require fewer restraints and are faster to erect.
 - minimise the number of pieces to erect.
 - reduce time working at high level to increase safety.
- Detailed design development commenced just six weeks before the steelwork was due on site, the 3-D model progressing in tandem.

- Supply chain ethos was essential. The programme was not achievable through traditional tendering means.
 - Gazeley partnered their supply chain.
 - an opportunity to showcase three years work on the steelwork contractor's supply chain: steel, erection, paint, bolts, transport, cold rolled purlins and rails were all partnered.
- Work with associates (eg the cladders, door and dock door company) pre-agreed – standard details were used to speed up design and drawing and eliminate interface problems.
- Effective project management the key.
 - Meticulous planning of the 85 loads, delivered every two hours in erectable lots to a site team of 30 men, four cranes and 16 cherry pickers.

The results

An extract from an on-site diary at the end of week four of the building contract read: "The steel frame is blitzkrieging its way across the field, the Barrett boys have had a fantastic week's production – 800 tonnes of steel erected, lined and levelled since they started seven days ago. We believe that this rate of production is a European, if not World, on-site production record for a portal framed building of this type. The organisation from factory through delivery to erection is as slick as can be."

By day 20 the entire 1600 tonne building was handed over to the main contractor, beating the programme by five days. This was achieved without compromising the most important factor on any building site, safety. Ground conditions were close to perfect, the most important factor in safe erection of steelwork.

Exactly 12 weeks to the hour from when the first foundation was dug, TNT's vehicles were being unloaded.

This project is a case study in the unique properties of steel allied to effective supply chain management, both are key to a successful outcome of a unique challenge and a satisfied client.





The Wellcome Wing at the Science Museum, London

In 1995 the Trustees of the Science Museum decided to extend the museum to provide additional exhibition space and a 3D Imax cinema. A design competition was held, which was won by a team comprising: MacCormac Jamieson Prichard, Ove Arup & Partners, and Davis Langdon and Everest. The winning entry offered a building with spectacular internal spaces which occupied a little over half of the available site and left space for a further building on the Queens Gate frontage. Funding has been provided by the Wellcome Trust and the Heritage Lottery Fund.

The competition concept was for a building supported by two rows of columns, 30m apart, about which were pivoted gerberettes - double cantilevered steel beams, which supported steel floor trusses at their inner ends, and were restrained by tie downs to the ground at their outer ends. The museum's brief required a 5.5m clear height on the exhibition floors, and this system reduces the effective span of the main trusses from 30m to 25m with a corresponding reduction in depth.

The structure has a basement constructed in watertight reinforced concrete supported on bored piles founded in the London clay.

In the four corners of the building are reinforced concrete stair and lift cores which provide horizontal stability. Between the cores are the main building columns, 110 x 750 reinforced concrete, which carry the majority of the building load. There are six pairs of columns, 30m apart, on an 8.5m grid in a east/west direction. They sit 5.5m inboard of the facades on the north and south sides of the building. These main columns span vertically from ground floor to roof level, and the roof slab acts as a beam carrying wind loads and stability loads back to the cores.

The gerberettes extend to the north and south faces of the building where they are held by a vertical "tiedown". The tiedown connects each gerberette on a column down to ground floor level, where the tie force is transferred into reinforcement bars cast into the retaining wall and thence to the foundations. CHS sections are used for the ties, rather than rods, as they are in compression in the temporary condition during erection.

Gerberettes are positioned at the same levels on each column, at a constant dimension below each exhibition floor. The main exhibition trays are supported by 25m long trusses, which span directly between pairs of gerberettes. Gerberettes are pinned to the columns and to the ends of the main trusses, so that this basic framework is statically determinate.

The floors comprise 150mm dense concrete on Holorib decking acting compositely with cellform secondary beams at 2.54m centres. The cellform beams span 8.5m between the main trusses and at the front and rear

edges of the floors they cantilever 3m beyond the trusses to enhance the impression of the floors floating in the space. The upper exhibition floors only connect to the rest of the building on their north and south edges. On their west side, they stop 3m short of the west wall. On their east sides they stop 6 to 10m short of the underside of the Imax structure, providing a diagonal slot from the ground floor 32m up to the roof which enables the visitor to see the floors and Imax within the overall internal space of the building.

The regular spacing of the gerberettes which support the exhibition trays is maintained for the Imax gerberettes. However the Imax cinema has a more complex arrangement of floors, with floor trusses required both a various levels and between main column lines. In order to connect the trusses to the gerberettes, the inner ends of the Imax gerberettes on each grid line are connected together by steel column sections. Load is therefore shared between these gerberettes, and trusses can be supported at any level. This section of the structure is not statically determinate and the effect of the construction sequence on loadsharing between gerberettes had to be investigated.

The floors in the Imax comprise 130mm concrete on Holorib decking generally, except for the base of the auditorium area where it is increased to 200mm thick to provide acoustic separation. The floors are supported by steel beams, at approximately 2.5m centres, spanning between the main trusses.

The roof structure is similar to the exhibition floors, with a concrete slab on Holorib decking acting compositely with cellcore beams spanning between main trusses supported from the inner tips of the gerberettes. The roof is designed for normal loads on top and the same suspended exhibit loads as the floors.

The West Wall fills the 30m wide by 30m high space between the west cores. It is supported by a structural steel frame, which hangs from the tops of the two cores and obtains horizontal support at floor levels from the core walls. It is glazed internally with blue glass, blue light being a theme of the internal space.

The primary structure comprises tubular steel trusses at main floor levels, which span horizontally between, and transmit wind loads to, the cores. The trusses are supported vertically near their ends and at mid point by a system of vertical and diagonal hangers, which take the vertical load to the top of each core at the end connection of the roof level truss. All other trusses have connections to the cores which slide vertically to allow for temperature effects. Connections to the core are also able to slide in the north/south direction, in order to allow the trusses both to act as simply supported, and to avoid stresses generated by changes in temperature. One connection in each truss does not slide in the north/south direction to ensure positional fixity.

The design assumed a specific erection sequence, which was provided in detail to the contractor, who elected to follow it rather than justify an alternative. The side aisles were erected first, and needed temporary bracing in the north/south direction until the roof slab was cast and provided the permanent support to the top of the main columns. At this point the north and south aisles formed stable independent structures, and the main trusses and secondary beams were erected from east to west by crawler cranes running on the ground floor slab, which was provided with additional temporary propping to the foundations.

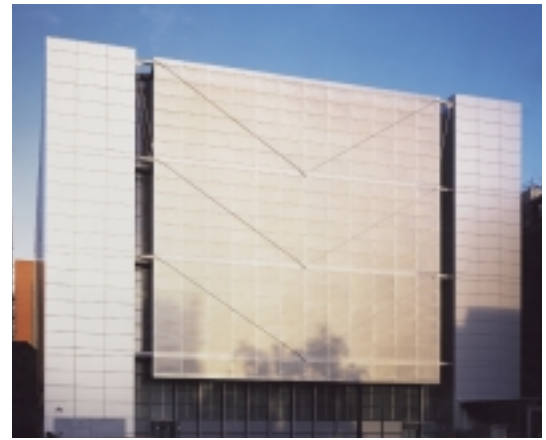

The Eden Project, Bodelva, Cornwall

The Eden Project, a showcase for global bio-diversity, is one of the most innovative and high profile Millennium Projects. Its network of "biomes", a sequence of great transparent domes that encapsulate vast humid tropic and warm temperature regions, make it the largest plant enclosure in the world built in the lightest and most ecological way possible.

The Biomes

The design, inspired by the Buckminster Fuller geodesic principle, evolved as a collaborative series of adjustments to a working 3-Dimensional computer model passed digitally between the architects, engineers and contractors. The final structure, the perfect fulfilment of Fuller's vision of the maximum enclosed volume within the minimal surface area, emerged as a sinuous sequence of eight inter-linked geodesic domes threading around 2.2 hectares of the site: a worked-out Cornish clay pit. These "Bucky balls" (named after Fuller) range in size from 18m to 65m radius in order to accommodate the varying heights of the plant life. Form follows function, a tangible expression of the client's aim to draw global attention to human dependence upon plants.

The biomes are an exercise in efficiency, both of space and of material. Structurally, each dome is a space frame reliant on two layers. The first, an icosahedral geodesic skin, is made up of hexagonal modules that range in diameter from 5m to 11m. Each comprises six straight, compressive, galvanised steel tubes that are light, relatively small and easily transportable. This makes it possible for each hexagon to be pre-assembled on the ground before it is craned into position and simply bolted to its neighbour by a standard cast steel node.

The primary layer is joined to a secondary one by diagonal Circular Hollow Section members at the node points. Structural stability is guaranteed by the "shell action" of the intersecting domes, that is, meeting of inner and outer structural members to form pinned connections. These are anchored to reinforced concrete strip foundations at the perimeter.

The exact location of the biomes on site has been determined by Solar Modelling, a sophisticated technique that indicates where structures will benefit most from passive solar gain. The architects have capitalised upon this gain by cladding the biomes with ETFE (Ethylene Tetra Fluoro Ethylene) foil.

ETFE represents less than one percent of the dead weight of equivalent glass. It is also strong, anti-static and recyclable, contributing to the overall realisation of the Eden biomes as tangible examples of energy-awareness in action. Elsewhere on the site, energy-awareness is manifest in both the Biome Link building and the Visitors' Centre.

Biome Link

The Biome Link primarily functions as the entry to the biome complex, and has thus been designed with the ease of visitor movement in mind. It is essentially two structures within one: a front-facing public facility and a two-storey service area to the rear.

The front-of-house element, incorporating a raised steel and timber walkway into the biomes, is of a sloping convex truss system. The trusses consist of curved top and bottom booms with pinned jointed internal strut and tie members. They are supported by raking columns at the front that have expressed pinned joints top and bottom and are stabilised by the building to the rear, a two-storey braced steel-framed structure. The main cellular beams are set out on a radial grid, which can accommodate variations in the span between columns. The secondary beams are at 2.75m centres.

The roof plane is "warped" at both ends, and its profile steel decking supports a green roof system that allows the Biome Link to seemingly melt into the "cool temperature zone" of its surrounding environment. Access is by way of a path that winds down through this zone from the Visitors' Centre.

Visitors' Centre

The Visitors' Centre is primarily an educational facility, with multimedia exhibits serving to introduce the aims and objectives of the project. The structure itself is equally informative. Dramatically curving to complement the contours of the quarry, it consists of two single-storey buildings linked by a partially covered courtyard. While the smaller (service) building nestles into the quarry, the main building thrusts outwards, offering a panoramic view of the biomes.

The main building is steel framed, with the roof beams spanning up to 20m between columns. The beams are set out on a radial grid and slope down at approximately 5° towards the service building at the rear. The roof structure, a steel deck capped with aluminium, forms part of the shallow cone resulting in a radial beam spacing of approximately 5m at the rear of the building and 6m at the front. To the south of the main building, it forms an overhang that shelters a rammed earth elevation. The use of rammed earth walling as a construction technique is local to Cornwall. It is also very much in keeping with The Eden Project's emphasis on recycling. The material used is the excess from excavation work carried out elsewhere on the site, geologically identified as containing the required range of particle sizes.

The building is stabilised at each end by columns that cantilever from pad foundations. The central section is loaded laterally by the fabric roof, in addition to the wind load. In this section, a truss system in the plane of the roof transfers the lateral loads to braced frames. The truss members are generally sized to limit the deflection of the horizontal truss where it cantilevers at each end.

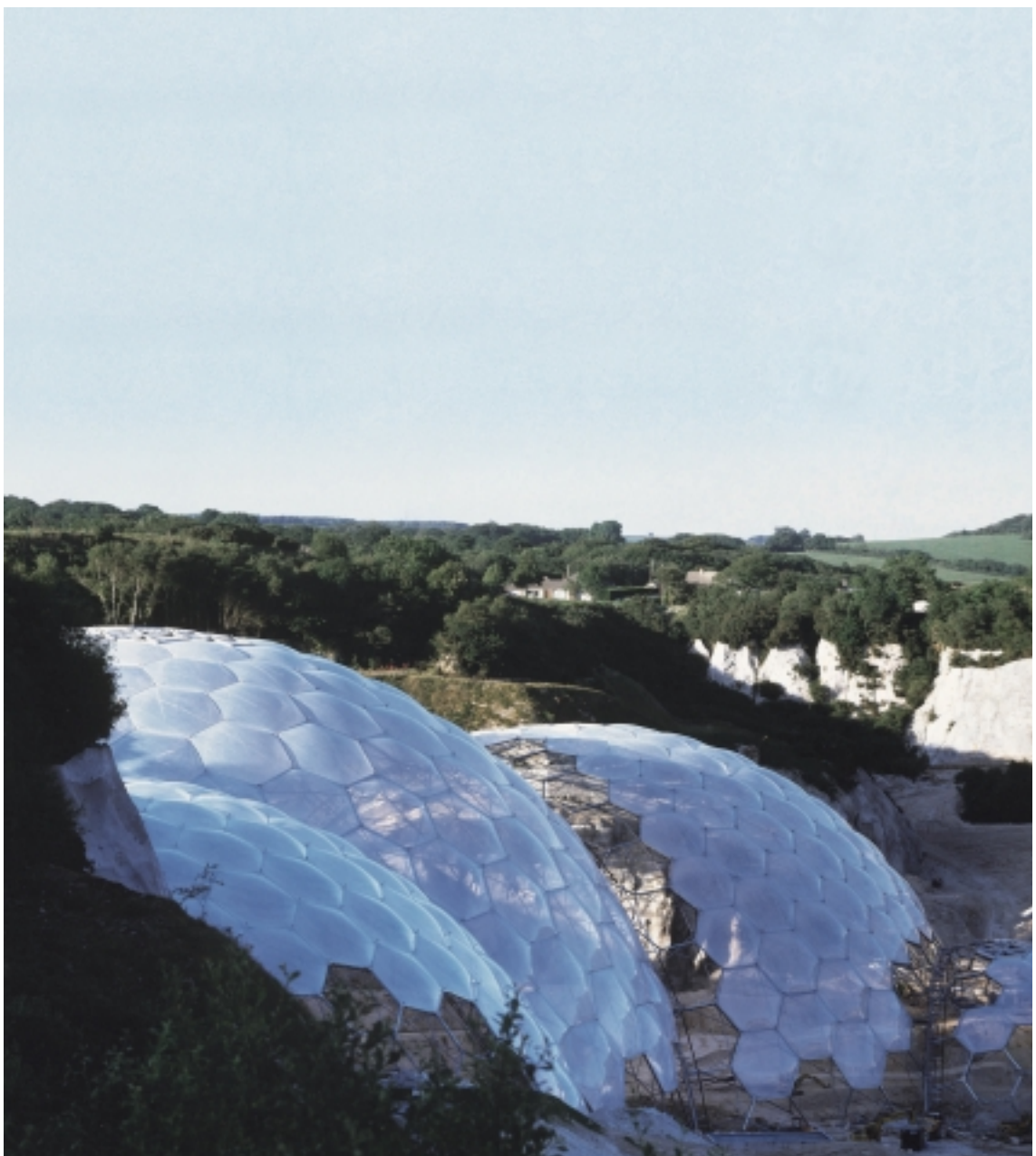

Renewal and Refurbishment of the Brighton Dome and Museum

The 200-year old Brighton Dome, Corn Exchange and Museum buildings are a combination of a unique historical heritage and styles of world importance. They were in need of renewal to sustain their continuing existence.

The buildings were originally commissioned in 1803 by George, Prince of Wales, later the Prince Regent as riding stables and a riding house. They have undergone many changes since then.

The original Dome, which, at 80ft diameter x 65ft high, was the largest timber-framed structure of its type in the world. The Dome was originally supported on a timber ring beam consisting of three wooden sections that circled the building and supported the main Dome Roof, this beam was in turn supported by a series of cast iron supports.

From 1863 until 1930 the Dome was used as Assembly Rooms. The Corn Exchange together with the Museum and Art Gallery were added in 1873. The Pavilion Theatre, seating over 2,000, was formed in the 1930s with the dome auditorium transformed by the addition of an Art Deco ceiling supported by steel trusses beneath the existing timber-framed Dome.

This then, was the first use of structural steelwork on this project. It was used in 1930 to sustain and modernise the building that had originally been constructed in 1803. Now, over 70 years later, steelwork has again been chosen to further extend the life of the buildings.

Part of the project involved the removal of the two proscenium columns added in the 1930s to replace the previous cast iron supports which were replaced by cantilevered beams inserted into the roof space. This involved steel-framed temporary works to support the existing timber Dome and 1930s trusses, then transferring the loads by jacking onto the new steel frame. All of the temporary steelwork and the new permanent steelwork had to be manhandled into the existing buildings and then erected from inside. It was a very difficult and congested site.

This work was successfully completed whilst maintaining the relative level of the existing domed roof structure. No measurable settlement or uplift occurred. Various areas of the refurbishment site are listed as Grade 1 and 2 status meaning that the works had to be carried out with sensitivity to the condition and nature of the existing structures.

Pre-loading of elements and jacking of existing structures were used to prevent excessive deflections. Substantial alterations, such as forming openings in walls, were dealt with by maintaining existing load paths and by spreading stress concentrations through box frames or spreader beams to ensure that the overall load distribution was not significantly altered.

Parts of the existing steelwork that had been dismantled, together with some of the new temporary support steelwork, were re-fabricated and incorporated into the new permanent works. In effect, the steelwork was re-used or re-cycled.

Approximately 500 tonnes of temporary and permanent structural steelwork was installed over a 22 month period between April 2000 and February 2002.



25 Gresham Street, London

25 Gresham Street is a 120,000 sq ft headquarters building providing 10 floors of column free office space. Developed by IVG Asticus Real Estate Ltd and now occupied by Lloyds TSB, it is situated on an island site in the City of London.

The site straddles the remains of a Roman fort and, in locations where foundation piles would otherwise have coincided with an archaeological deposit, the load paths were transferred using steel A-frames within the basement level.

The structure is designed as a braced frame with simply supported floor beams spanning between columns. Fabricated steel sections with an integrated service zone achieved 12m clear spans from the building perimeter to the core. The central braced core provides lateral stability for transverse wind loads and the suspended south elevation. Vertical braced bays in the east and west stair cores provide additional resistance to torsion and out of balance loading on the hangers. Diaphragm action of the floor plates transmits lateral wind load from the perimeter cladding to the core.

The key architectural concept focuses on the relationship with the adjacent garden, originally the St John Zachary Churchyard. Accommodation is organised around an open sided south facing atrium overlooking the garden. The atrium contains the principal vertical circulation, four glass lifts reached from a series of glass floored bridge decks and the scheme extends the garden with terraced planting beds climbing up the external face of the atrium. The imaginative use of structural steel enables the southern

edge of the floors to be hung, thus avoiding any ground floor columns along the garden boundary. Steel vertical braced bays around the central service core resist the overturning moments induced by the inclined hangers. Plan bracing transfers the resultant push/pull horizontal forces at first and ninth floors from the hanger node points to the central core.

The diagonal tensile rod ties that provide support for the principal structure were assessed in a detailed fire-engineering analysis to ascertain what effect an internal fire would have on the stability of the structure. The initial assessment was based on the ratio of energy input from the fire to the mass of the hanger available to absorb the energy. To determine the performance of the hanger more accurately, assessors calculated the temperature of the environment to which a tension rod was likely to be exposed in a fire. Taking account of the thermal properties of the steel, the temperature of the fire and the duration of exposure, it was possible to calculate the peak temperature achieved by the hanger. Temporary props supporting the first floor enabled the simultaneous construction of the suspended south bays with the main frame up to the hanger connection nodes at the ninth floor. Hydraulic jacks lifting the hangers transferred the load from the temporary props to the inclined hangers. Tension to the hangers was applied progressively, in pairs to control distortion sway on the structure. The measured movements were continually checked against the predicted theoretical values, determined from the detailed analysis of the frame and the tolerance allowances of the cladding assembly.



Hampden Gurney School, London

BDP has broken the mould of inner city education buildings with Hampden Gurney School. In contrast to the single-storey schools often found in the densest parts of our cities, BDP has designed a multi-level primary school that creates the corner piece of a Marylebone city block in London.

The project includes two new six-storey apartment blocks on each side, the profits from which funded the redevelopment of the school.

Classrooms are set on three levels above ground floor and there is a technology teaching room on the roof. Children "move up" the school from nursery level at the ground floor. Play decks, located at each level of teaching, are separated from the classrooms by bridges across the central atrium. The decks provide safe, weatherproof play for different age groups adjacent to their classrooms as well as the prospect of open-air classrooms on warm days. The hall, chapel and music and drama room are set at the lower ground level.

The structural concept responds to two key aspects of the Client's brief – the need for a flexible space for sports, dining and worship at lower ground level and strict programme constraints linked to term times and phased transfer.

The steel framed structure has an innovative roof truss that suspends the centre of the building to create the 16m clear span at lower ground level – the truss picks up the loads by means of Macalloy steel hangers connected to each floor at mid-span. Only when one enters the basement does the structural concept become apparent.

The column free area creates a flexible space at lower ground level offering a host of possibilities for play, worship and performance. The steel bow arch is visible on the roof – a lightweight tensile PTFE canopy springs from the truss, protecting the atrium below and creating a sheltered and inspirational space for environmental learning and experimentation.

BDP designed the structure for simple and fast construction – the entire steel frame was erected on temporary columns. Macalloy hangers were then installed and tensioned, transferring load from the temporary columns into the roof truss. The structure was simply lifted off the temporary compression columns when the load transfer was complete, allowing easy removal of the temporary columns.

Sustainability was considered throughout the design process. BDP 'designed in' demountability of the structure – steel columns could be inserted in the hanger positions and, after load take up, the building could be demounted in a traditional way. Also, the play areas are open to the fresh air and the long side of each is curved to the south to enjoy all day sun. The central atrium provides cross ventilation to the naturally ventilated classrooms.

The construction budget for the school was £6m. The structural frame comprised 200 tonnes of steelwork and the average cost of the primary frame was £1,000 per tonne and of the arch £2,000 per tonne.



Tattersalls Grandstand, Newbury Racecourse

The new Tattersall Stand at Newbury Racecourse in Berkshire provides upgraded betting, viewing and catering facilities whilst also offering a new venue for exhibitions and conferences during non-race days.

The structural form was driven by the architect's intent for a clear, bold, expressive X-frame. Primarily this differs from conventional stadium design in that the roof was not designed to cantilever forward but rather to be propped by the primary structure at its tip. The geometry of the X-frame was developed to provide efficiency within the structure whilst satisfying the client's brief for clear floor plates. By ensuring that the horizontal, vertical and diagonal elements of the frame connected at discrete node points, forces were resolved into axial loads thus minimising bending stresses.

The structure consists of six X-frames spanning 36m on a 12m grid with service cores attached to the back. Steppings, to the front, rise to a bar level at the central node point of the X, above which is a restaurant level with projecting balconies.

The client required that the old stand be demolished and the new stand be in place between the dates of the annual November Hennessy Gold Cup race meetings. With under a year to construct the stadium the design and fabrication maximised off site fabrication in order to deliver a 'kit of parts' that could be readily assembled on site.

Structural stability is inherent in the plane of the X-frames, whilst bracing within the cores provides stability to imposed lateral loads in the orthogonal direction. Within the mechanism of the X-frame, vertical ties resolved the structure from out of balance loading thus preventing the central node point acting as a fulcrum about which the upper structure could pivot. A horizontal tie between the feet of the X-frame ensured that the structure resolved itself into a discrete element whereby only vertical and applied lateral wind loads are transmitted to the piled foundations.

An assessment of the sensitivity of the steel frame to dynamic loading was carried out using a finite element model. Due to the angle of rake, the primary X-frame elements do not behave like simple columns but have a complex beam-column characteristic in which the structure has a tendency to combine vertical deformation with sway. The analysis studied the global type mode shapes and the largest conceivable energy input of a capacity crowd jumping in time.

The relatively short spans and large number of openings in the service cores favoured a concrete filled metal decking that could be simply trimmed to suit the irregular floor plate. The bar and restaurant clear floor plates were constructed using pre-cast concrete planks with a structural topping spanning 6m.

To meet the architect's specification for a high finish to the concrete steppings the units were fabricated off site and sequenced in delivery to be lifted straight into position so as to minimise handling and the possibility of damage.



Premier Place, Devonshire Square, London

Following a limited competition in 1996, Bennetts Associates were appointed by BT Properties to design an office building on the site of its redundant Houndsditch Telephone Exchange.

Having gained planning permission, the site was bought by AXA Sun Life who commissioned Bennetts Associates to develop the project to completion, which was achieved within its £45 million budget in October 2001. The building has been pre-let to the Royal Bank of Scotland.

In sympathy with the industrial Victorian warehouses nearby, 2 1/2 Devonshire Square expresses its structure within a rugged, load-bearing steel and glass façade. The design orientates the building away from Houndsditch and places the main entrance on the corner of Devonshire Square.

Incorporating the client's floor space requirements, respecting the proximity of a conservation area and rights of light limitations, the building steps back from Devonshire Square on the sixth floor, rising up to nine storeys along the Houndsditch elevation.

Lifts and staircases in the glazed service cores animate the exterior of the building and provide a series of minor landmarks at critical points in the townscape. These vertical elements, accentuated by towers of meeting rooms framed by shear walls clad in granite, act as "bookends" for the principal steel elevations. Solar shading adds to the textural qualities of the southern façade.

The decision to expose the structural steel frame of the Devonshire Square building created a number of inherent technical challenges:

- developing an appropriate language of steelwork detailing and finishes
- addressing potential cold bridging problems
- vapour and condensation control
- fire engineering issues
- understanding the movements, deflections and tolerances of exposed steelwork
- corrosion protection issues

Standard rolled sections are manufactured as general purpose members with a relatively wide dimensional tolerance for length, depth, straightness and surface quality. While, in normal use, this is not a problem, when the steelwork is exposed on the façade, these tolerances may not achieve an appropriate visual standard commensurate with the cladding of a city office building. The façade steelwork was therefore ordered direct from the manufacturer with a more precise dimensional tolerance, and to the highest surface quality to minimise laminations, rolling marks, surface pitting and handling damage.



The Lowry, Salford Quays, Manchester

The Lowry project on Salford Quays has been designated the Nation's Landmark Millennium Project for the Arts. The Lowry consists of two theatres, two galleries and various facilities for conferences and general hospitality.

In the Lyric Theatre two rows of columns based approximately 3m apart set out on an oval grid as defined by sight lines and linked back to shear walls by curved steel beams were used to provide the transverse stability. These columns were used to support cantilevered trusses which in turn supported the seating. The central core columns and beams were painted with intumescent paint to satisfy the one-hour fire rating requirements.

Set on the outside perimeter of the leaning concrete wall, the Lyric Foyer provides access from the theatre entrances to the galleries and exits. The roof beam consists of a plated 610 deep beam cut to suit the architect's requirements. The difficulty of connecting this to the cruciform column which was made up from a 356 UC with Ts welded to the web was overcome by means of a tubular insert welded to the top of the column.

The Adaptable Foyer comprises four cruciform columns made from four 120 x 120 SHS welded together. These in turn support a tree top configuration made from tapered beams out of 610 UCs. The tapered beams supported 165 UC purlins which in turn supported the metal decking roof. A curved 152 RSC formed the edge support.

The two Galleries comprise longitudinal trusses supported on 322 x 25 CHS columns with the bottom boom supporting first floor cell beams and the top boom supporting similar transverse roof trusses. The connections had to be kept as clean as possible to satisfy the architect's requirements for clear uncomplicated lines as the steelwork is visible both internally and externally.

The Diagrid Tower is used to house the artwork when not in use and the architect required this to be the highest visible feature using symmetrical steel beams to form a cylindrical shape with no connections visible on the perimeter. Four beams connected together formed a faceted diamond shape and this pattern was repeated around the cylinder and from bottom to top.

Set at the entrance to the Lowry, the Canopy was designed as an imposing architectural feature as well as a functional structural item. Supported on two sets of A-frame legs with six smaller CHS supports the structure consists of a central toblerone shaped truss on which are supported frames with a sloping top boom and curved bottom boom to give the architect's required shape. This structure was covered in perforated cladding.

Why Steel

The design team recognised from the outset that the structure had to satisfy both structural and architectural requirements. The geometry of the structure with its various leaning walls, cylindrical shapes and large spans meant that, for the majority of the structural framing, steel was the only logical choice.

Despite its complex nature the engineers could design the structure confident that the steelwork would achieve their requirements within the tolerances required.

From an installation perspective steelwork was the only logical choice due to the limited nature of the space available on site. Vast areas of space were not required for temporary support/propping during installation as the steel frame was designed to be stable within its own right and installed in a manner to minimise any temporary bracing required. The speed of erection also confirmed steel as the correct material for the structural framing.



**EARLY HISTORY OF
STRUCTURAL STEELWORK
IN GREAT BRITAIN**



hatsoever thy hand findeth to do do it with thy might



In the NINETEENTH
CENTURY the Northland
from the World's Fair can be
seen with the assistance of a...

EARLY HISTORY OF STRUCTURAL STEELWORK IN GREAT BRITAIN

By Alan Watson MBE

CHAPTER 1 – BEFORE 1885

Retrospect

The history of Structural Steelwork, in common with the history of practically any other subject, does not have a particular starting point, and an arbitrary threshold must be chosen.

After thousands of years of building in timber and masonry, it is only in the last quarter of the second millennium that metal has been used; indeed, it is only just over a hundred years since any significant steel structures appeared.

Cast iron, wrought iron and steel have developed one from the other and each has been incorporated into buildings and bridges using continuously improving techniques. It may well be worthwhile, therefore, to look briefly at the beginnings of the structural use of metal and follow its progress over what is, after all, a comparatively short period of time.

Material

The so called 'Industrial Revolution', it could be said, had its origins in the accidental coincidence of a number of happenings. One of great importance was Abraham Darby's discovery in the early years of the eighteenth century, that coke could be used in place of charcoal for smelting iron in a blast furnace. Cast iron became plentiful and cheap, finding endless uses domestically and industrially. It was easy to mould, had reasonable resistance to corrosion and had a formidable compressive strength, but it was unfortunately brittle and had poor tensile qualities. It must have seemed strange that, by using the same raw materials in another process, wrought iron could be made, exhibiting quite different characteristics. It was tough, malleable, had good tensile properties and could be welded simply by hammering pieces together at white heat. Unfortunately the production process was slow, output was limited and the end product was, consequently, very expensive.

So the alchemists went to work to find the philosopher's stone that would turn the now abundant supply of cast iron into a material with these very desirable qualities, in much larger quantities and at a more reasonable price. There were a number of false starts and claims that could not be substantiated but credit for the invention that stimulated a huge increase in the production of wrought iron is generally accorded to Cort who, in 1783, developed the puddling furnace. He also made another significant contribution in the invention of grooved rolls which enabled all manner of shapes to be produced with economy. Some were decorative but the greatest importance to the fabricator was the rolling of structural sections, initially angles and tees. The puddling process was still, however, highly labour intensive and was limited by what a man could manipulate from the furnace to the hammer, usually about 100 lbs. These small blooms could be combined by forging or rolling but even in the middle of the nineteenth century, it was exceptional to build up ingots weighing as much as a ton.

There was an urgent need for a better method and Bessemer, who was neither iron maker nor metallurgist, actually found something that he was not really looking for – mild steel. He was an able inventor and was trying to devise improved ways of producing wrought iron and carbon steel not, it must be said, for structural purposes, but to replace the brittle cast iron used in gun barrels. It was unfortunate that after the tremendous excitement created by the publication of Bessemer's work in 1856, the process proved to be unreliable and it took two further years of experiment to establish that good quality steel could only be made from iron that had been smelted from low phosphorus ore. In the meantime the iron masters, not easily persuaded that all was now well, had lost interest which encouraged Bessemer to set up his own plant in Sheffield. Output expanded quickly, allowing him to fulfil his original purpose, since his steel was used to make guns for both sides in the Franco-Prussian war.

The initial problems with this process, and the suspicion that it created, retarded the adoption of mild steel for building purposes. It was 1863 before the War Office accepted it but the Admiralty refused to allow its use until 1875, while the Board of Trade did not permit steel bridges until 1877. Meanwhile, another steel making process was gaining favour, named after Siemens, whose expertise, like that of Bessemer, was not in the field of metallurgy. His work as a furnace designer was taken up by Emile and Pierre Martin who developed its use for steel making. Subsequently, Siemens himself, after a year of experiment, set up the Landore-Siemens Steel Company gaining, twenty years later, a contract for 12,000 tons of plates for the Forth Bridge. The Siemens, or open-hearth process, was much slower than that of Bessemer but each cycle produced a greater quantity of steel and the ability to use large amounts of scrap made the two processes comparable in cost. Also, the slower process gave time for chemical analysis and correction as the metal was being refined, leading to the claim of greater consistency and reliability. This process provided steel for the construction industry for over seventy years.

So, by the end of the 1870s two successful methods of steel making were established. Confidence was restored, the industry flourished and wrought iron, which had held sway for most of the century, fell into decline. It is appropriate that in the final act, before the curtain fell, wrought iron was chosen in 1887 to build one of its finest structures – world famous – the first building to reach a height of 300m – the Eiffel Tower.

The huge demand for wrought iron had led to the formation of many companies engaged in its production. Apart from the ironworks, where each blast furnace might serve as many as twenty puddling furnaces, there were also many wrought iron makers who bought their pig iron and built their own furnaces. After all, the technology was fairly simple and the capital cost of setting up was not enormous. Not all of them, of course, converted to steel making because the demand for wrought iron continued, although in continuous decline, right up until the 1950s. Nevertheless, after Bessemer and Siemens had done their

work, it was not long before there were in excess of two hundred steel makers in England and Wales. The success of wrought iron production, indeed the world leadership, led to an unfortunate complacency and steel making in Great Britain started with problems which took nearly a century to resolve. There were too many companies operating on too small a scale, many with too wide a range of products. They were all fiercely independent. They suffered from nepotism where management was a matter of relationship rather than ability and they seemed blind to the fact that both production and efficiency were, in the USA and Europe, rapidly overtaking them. Bankruptcies, liquidations and amalgamations reduced the numbers over a period of time, but they were never sufficiently profitable to undertake the research and development that was necessary. Even so, their problems were by no means all of their own making. As an industry which relied on continuous volume production, it was the most vulnerable to any economic downturn, leading to serious ills from fierce price cutting. Also, transport had so much improved by this time that there was an international trade in steel and our manufacturers were further embarrassed by low priced imports from countries which protected their own industries by imposing tariffs.

As the years went by, unbridled competition, poor management, violent trade cycles, wars and political interference all impinged on the British steel industry which makes it all the more astonishing that late in the twentieth century, it emerged as a single, efficient public company.

Labour and Management

Since the beginning of the Iron Age, so important was the work of the blacksmith that he became part of folklore and, additional to his skill, he had ascribed to him the virtues of strength, integrity and rustic wisdom. The making of weapons gave him great power, there was magic in using fire and water to change the nature of metals, and perhaps something symbolic in joining and welding. The art of the smith changed little so long as the processes of metal manufacture restricted the quantities available but his world suffered an upheaval as new methods were developed. Cort's puddling process and the ability to roll plates, even though they were at first small, coincided with a growing demand for steam boilers and the early years of the machine tool industry. New products, new tools, new materials together demanded a new range of skills and blacksmiths were supplemented by a new designation of tradesmen, known as boilermakers, who were responsible for marking and manipulating plates, drilling, punching, riveting and caulking, each of which became a trade within a trade, which has been the cause of countless disputes ever since. And, of course, they were involved with all the other parts, the fire grate, the flues and the supports which required working not just with plates but with rolled sections as they became available. With their new skills, their activities extended into making iron ships, gas holders and tanks and, indeed, to the vessels used in the early days of the chemical industry. It was also natural that these same men should adapt to building bridges and all forms of structure. Thus came about the huge increase in the number of boilermakers in the middle years of the nineteenth century.

The onset of industrialisation had been abrupt. The establishment, the law, the employers and the large groups of workmen who were brought together were ill equipped to cope with their new situation where mutual suspicion and fear, just as

much as greed, created the divisions between capital and labour. The law was on the side of the employer who gave ground but slowly and strove later to regain that which he had conceded when adverse trading conditions allowed. The early romantic notions of the dignity of labour and the prospect of an ever increasing level of employment and prosperity, gave way to realisation of the horrors that industry had generated, of the squalor in which people were herded and the near starvation brought about by what we today call trade cycles but which in those days were convulsions. It is not surprising that those with common interests and experience obeyed a protective instinct to combine and support each other nor that their determination and loyalty should be fortified by attempts to suppress them.

So it came about that in 1834, a group of fourteen Manchester men enrolled in the newly formed Society of Friendly Boiler Makers with the attendant ceremonies, initiation procedures, oaths and passwords. A courageous move in a climate so hostile to the formation of any trade union and at a time when the Tolpuddle Martyrs were sentenced to transportation simply for taking an unlawful oath in their initiation ceremony. The original intention was protection for the members against unemployment, sickness and injury and indeed quite generous benefits were proposed. However, the vagaries of trade were such that the youthful society bordered on bankruptcy at each lurch in the economy and it was only by reducing benefits in prolonged hard times and increasing contributions when most people were employed that ends were made to meet. By good management the Society survived and prospered and by 1880 it had become a power in the land, earning a reputation for militancy, insistence on trade demarcation and the tremendous solidarity of its membership. And this was the principal trade union in the structural industry as the material it used changed from wrought iron to steel.

Education

That Great Britain lagged behind other industrialised countries in the education of its people is well recorded and although the voices of more enlightened employers and teachers were raised, they had little effect on an establishment which feared the development of working class minds and regarded the study of the classics as appropriate training for young men who would ultimately inherit the manufacturing enterprises created by their fathers. Technical education was frowned upon by employers and employees both of whom believed that trade secrets and craft 'mysteries' would be revealed to the world at large. Another argument, conveniently espoused by the anti-education lobby, was that propounded by Samuel Smiles which held that 'Self Help' was the answer and in his words 'The great inventor is one who has walked forth upon the industrial world, not from universities but from hovels; not clad in silks and decked with honours, but clad in fustian and grimed with soot and oil'.

The domestic system whereby a craftsman, very often working on his own, was responsible for the training, education and wellbeing of his apprentice, was destroyed by the growth of factories. The training that a boy received became a matter of chance and in the worst situations apprentices were regarded simply as cheap labour. The situation of the aspiring engineer was not dissimilar except that he had to pay a premium to the practising engineer to whom he was apprenticed, thereafter eking out a living by taking part in the business routine of the establishment. In effect this meant that he had almost certainly

emerged from the middle classes since he obviously needed financial support.

It would be untrue, however, to say that technical education was non-existent. Mechanics' Institutes, a development of the work of George Birkbeck in Glasgow, made their appearance soon after 1800 and by 1850 there were over six hundred in England and Wales. Their greatest impediment was the lack of primary education which reduced the number of candidates from the ranks of artisans and they were, to a large extent, taken over by more privileged people. The annual meeting of the Liverpool Mechanics Institute proudly reported, in 1838 that 'this institution, though originally formed for the benefit of mechanics, has gradually become a great educational establishment for the middle classes'.

The Great Exhibition of 1851, followed by the Paris Exhibition of 1855 focused attention on the contradiction that we were dependent on our manufacturing skills yet were heedless of technical education. Prince Albert recognised our needs and intended that the profit from the Great Exhibition should be put towards industrial education. With that end in view, the whole of the South Kensington estate was duly purchased but the scheme met considerable opposition and little progress was made in the early years although South Kensington has subsequently become a very important centre of technology.



By this time, one or two universities had already shown an interest in scientific subjects. Glasgow appointed a professor of engineering in 1840, once again demonstrating that there was a greater appreciation of education north of the border. Others soon followed though the take-up of places to study scientific subjects was initially slow.

One of the most significant and far reaching developments stemmed from a meeting of the City of London Livery Companies in 1876 which resolved '...that it is desirable that the attention of the Livery Companies be directed to the promotion of Education not only in the Metropolis but throughout the country, and especially in technical education with the view of educating young artisans and others in the scientific and artistic branches of their trades.' Thus was founded the City and Guilds of London Institute for the Advancement of Technical Education which rapidly expanded a system of technological examinations, the success of which can be measured by the records which show that in 1880 twenty four subjects were taught with 515 passes and by 1900 these figures had risen to sixty four and 14,105. But education cannot simply be turned on like a tap; there must

be buildings and equipment and above all, competent and experienced teachers. It is a great credit to everyone concerned that the system made such rapid progress although most praise should perhaps be reserved for the students of the time who drove the system along with their passionate desire to learn.

Machinery and Equipment

It is very surprising just how much machinery was available in the middle of the nineteenth century, largely due to the genius of Joseph Bramah, not just as a mechanical inventor but also as a teacher and inspiration to generations of gifted men. One of his pupils, Henry Maudsley, a leader in the development of machine tools, also trained both Nasmyth and Whitworth and in the first fifty or sixty years of the nineteenth century, the science of mechanical engineering made astonishing progress.

This was the age of punching and riveting. Methods of construction were similar in buildings, bridges, boilers and ships where components were built up out of plate and small rolled sections, mainly angles and tees. The constant drive for more economical production led to the development of machinery which would cut and shape plates and punch holes for the rivets which held everything together. Since plates were small, due to the limitations of wrought iron production, there were certainly plenty of holes and rivets!

In 1847, Richard Roberts, who had also been a pupil of Maudsley, designed, at the request of Mr Evans, the contractor for the Conway Tubular Bridge, a hydraulic machine worked on the Jacquard principle which at one stroke punched up to twelve one and a half inch diameter holes through plate three quarters of an inch thick. Then at the Great Exhibition of 1851 a shearing and punching machine attracted the attention of Queen Victoria who reported that it was '...for iron of just half an inch thick, doing it as if it were bread!'

There were attempts to automate other processes, as well, sometimes as part of the continuing search for economy and occasionally to overcome the effects of strikes. Fairburn, in 1840, invented a riveting machine which, it was said, with two men and two boys could drive 500 one inch rivets per hour, thus making redundant most of his boilermaker riveters who had been on strike because two men had been employed who were not in the Union. Radial drilling machines were patented in the 1830s and the twist drill, an American invention, came to us in 1860, about the same time as Mushet's work on tungsten alloy steel. Practically every machine that was to be found in a structural fabrication shop in the 1950s had been available, though perhaps in a less refined form, from the time that steel first came into use. Indeed, many workshops in the 1950s looked as though they had changed very little in sixty years with their dirt floors, the cumbersome cast iron frames of combined punch, cropper and shears, simple hydraulic presses and heating, only on particularly cold days, by means of coke braziers. Methods, of course, changed but not to the degree that might be imagined. There was a slow replacement of rivets by bolts as they became reliable and less expensive and steam was replaced by electricity but the fundamentals were the same. It would be possible to trace the history and development of each machine that was used, which would certainly prove interesting, but that is a study for some other time.

Hydraulics had, for some time, been widely used for a variety of engineering purposes where the transmission of power was desired. Pressing, punching, shearing, riveting and lifting by both crane and jack, all took advantage of its simplicity and no better example can be quoted than the construction of the Britannia Bridge over the Menai Straits. Completed in 1850, each girder, weighing over 1,500 tons, was raised to a height of a hundred feet above the water by the use of a hydraulic lifting frame, made, incidentally by Bramah, which later took pride of place in the Machinery Court of the Great Exhibition. The same technique was used in 1859 on Brunel's Saltash Bridge and much later on the Forth Bridge where the approach spans, fabricated by P & W McLellan of Glasgow, were built on staging and jacked up from the piers which were built up beneath them.

In the 1830s, Roebling in the USA, invented wire rope which had a profound effect on many industries. It was hard wearing and very compact for the weight that it would carry. Deep mining and tall structures that both require lifts would be impractical without it. Of course, it did not immediately come into use and it took some years for economical manufacturing techniques to be perfected. Once it became readily available, however, it made possible cranes and winches of much greater capacity and enabled the contractor to fabricate larger and heavier pieces in his workshops.

Site erection owed a great deal to the experience and knowledge, hard-won over many centuries, of the nation's seafarers – who better, after handling the complicated rigging of large sailing ships, raising and lowering the heavy masts and booms? Nor is it surprising that there are so many words in common, bow-strings and backstays, booms and masts, luffing and splicing and many more besides. Was it the rigger, a term used on both land and sea, whose macabre sense of humour named the jib after the gibbet and the derrick after the public executioner of the time?

Awed by the size and complexity of structures, people must surely have wondered at the skill of the men who put them together. How on earth did they cope with large and heavy pieces of metal? Not, as might be supposed, by sheer brute force because men have always exercised extraordinary ingenuity. Mobile cranes only became generally available after the Second World War and even as late as the 1940s it was fascinating to observe the skill of steel erectors when manoeuvring heavy pieces on confined sites. Guyed derrick poles, levers, jacks, hand winches, small bogies and rollers – sometimes the illicit use of oxygen bottles – were the tools of the trade. Of course, it was economical on larger sites to put up a derrick crane, but even this might well have been hand operated. Derrick cranes, steam driven, came into their own in the late 1800s, gradually increasing in capacity until with jibs of 150 ft they could lift loads as great as 50 tons. With their ruggedness and the facility with which they could be dismantled and re-erected, they became, and in some remote situations still can be, a very useful tool indeed.

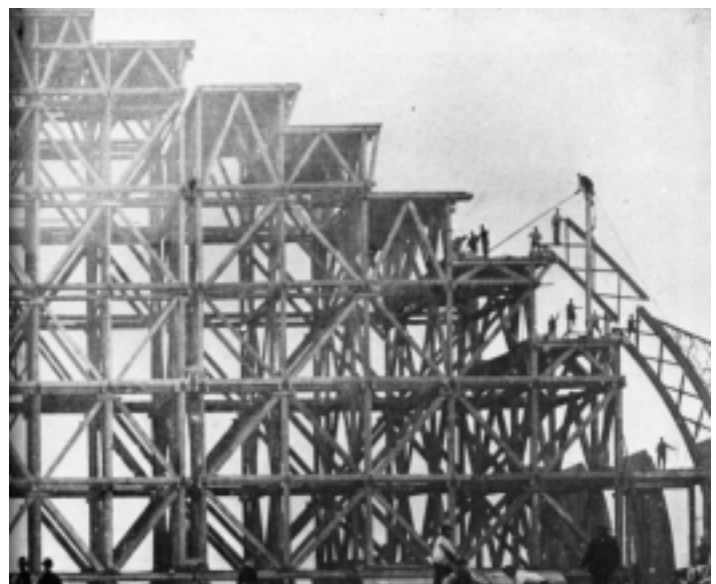
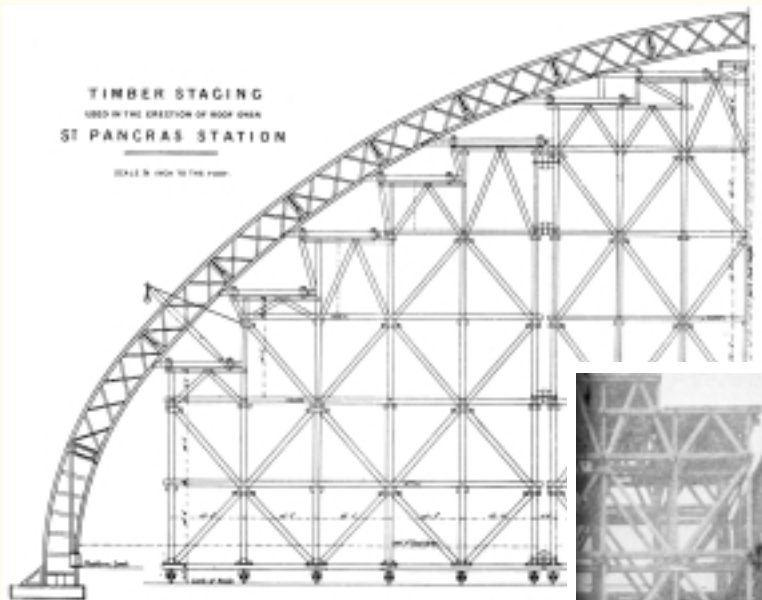

One aspect that is a study all of its own is that of the transmission of information. How, for example, did Telford, Brunel and Stevenson transmit their instructions to the workshops and to the men on site? Everything that was written or copied was done by hand, and drawings were not reproducible, such that it is hard to imagine the beautifully prepared details on cartridge paper being used on the shop floor. Checking the finished article could not have been easy, either, without ready access to drawings. These are the factors that are not recorded, yet the introduction of equipment which copied drawings must have had a dramatic effect on production. The process of making 'blue prints' was established as early as 1837 by Sir John Herschel but relied on the sun to provide a light source. The introduction of the electric arc towards the end of the century established a huge advance in one of the first examples of 'information technology'.

Structures

The early structural use of cast iron could well have been unrecorded props and lintels around the ironworks themselves but Smeaton claimed to have used cast iron beams in the floor of a factory in 1755, and overcame the disparate values of tensile and compressive performance by designing asymmetrical sections, where the area of the bottom flange was several times that of the top. Another early use of the material was in the columns which supported the galleries in St Anne's Church, Liverpool in 1772 while in 1784 John Rennie built Albion Mill in London with a frame entirely of cast iron.



From the middle of the eighteenth century, the ironmasters, in their enthusiasm, turned their hand to making everything that they could from a material which was now becoming plentiful. 'Iron-mad Wilkinson', one of the most famous, made a cast iron boat and confounded the scoffers when it actually floated. He went on to build a church for his work people where the door and window frames were cast iron, as too was the pulpit. His only failure was in the casting of his own coffin, which sadly could not be used since prosperity had substantially increased his girth. But his greatest contribution, at least in the eye of the structural engineer, was as an enthusiastic promoter of the iron bridge, built in 1779, and which gave the name to the small town which surrounds it. The new material was slow to make its mark, however, and it is not until 1796 that Tom Paine, when

not engaged in radical politics which included writing 'The Rights of Man', turned his hand to bridge design. A frustrated export to America led to his bridge being erected in Sunderland where, with a span more than twice that of Ironbridge, it accounted for only three quarters of the weight.

Iron bridges might, for many years, have simply been regarded as curiosities, had it not been for the happy coincidence that Thomas Telford took up the position of Surveyor of Public Works for the county of Shropshire in 1787. Whether he was inspired by the original iron bridge, or swayed by the lobbying of Wilkinson, who became his firm friend, we know not, but he was not slow to realise the potential of cast iron, and became one of its greatest exponents. Telford immediately got away from the confused, jig saw puzzle that was Ironbridge and provided elegant designs with economy and simplicity of detail. As roads and canals spread across the country, cast iron bridges and aqueducts proliferated, many of which are still in existence and in daily use.

There was a demand, too, for factories and warehouses where cast iron columns supported beams of the same material with brick arches between them. These were the so-called 'fireproof' buildings which achieved popularity amongst those mill owners who had seen so many wooden floored structures burn to the ground. There were even examples where the hollow columns were used to exhaust a steam engine, thus creating a primitive central heating system and amply demonstrating resistance to corrosion which is one of cast iron's great virtues.

In this way, metal structures made their first appearance and in spite of the problems of transporting heavy and unwieldy sections from foundry to site, engineers of the time took full advantage of the excellent compressive qualities of cast iron, and of its economies. The process of casting iron was such that repetition was not only easy but also highly desirable in order to amortise the cost of patterns. This was the basis of the enormous industry that developed and formed the beginnings of mass production of complex components for the building industry. Of course, the prefabrication of buildings was not a new concept. Indeed enterprising exporters had been actively engaged in satisfying the need for shelter in many parts of the world where both materials and labour were in short supply. At first these were simple timber huts, the ancestors of the garden sheds, loose boxes and summer houses of today, but the ravages of termites and the danger of fire made metal structures in many ways more attractive, particularly after the invention of machinery to produce, economically, the corrugated iron sheet. That a flat sheet could be made much stronger by fluting, indenting or corrugating had previously been well known but since no mechanised process had existed, the cost was prohibitive. Henry R Palmer's patent of 1829 described the use of fluted rollers which quickly transformed red hot wrought iron sheets into a product which is still widely used today. Now, of course, the metal used is steel but the world still refers to 'Corrugated Iron Sheets'. Cheap, strong, light and easily transportable in robust bundles, they could be fixed with remarkable speed and equal facility to wooden or metal frames by comparatively unskilled labour and they were used on every conceivable type of building from cathedrals and town halls to privies and pigsties. Like so many other prefabs many of these 'iron buildings' remained in use long after their designed life, indeed in some parts of the world they are now protected as part of the local heritage. But, unless designed with great sensitivity, they were ugly. And unless very carefully maintained, they were exceedingly ugly.

The term 'iron buildings' covered many permutations; they could be timber framed and clad in flat or corrugated sheets; they could be similarly metal framed in either cast or wrought iron; they could be entirely of cast iron like the amazing lighthouses, trial assembled in this country and exported to many parts of the world, and in the ultimate, the term could describe the complete cast iron façade, in any architectural style, or mixture of styles, that satisfied the customer's aspirations. Drawings of some 'iron buildings' are, of course, still available and are intriguing in the subtlety of their construction details; in other cases the descriptions simply leave the readers to conjure up their own mind-pictures. Mr Laycock of Liverpool, for example, tells us of making in 1843 'An iron mansion for sending to Africa' and later 'A neat iron cottage built for the use of two maiden ladies residing in the island of St Lucia'.

Nor were industry and commerce neglected. Fairburn exported a complete corn mill to Turkey in 1840, fabricated entirely in iron, part cast and part wrought, with a corrugated iron roof and he claimed that this was the first complete iron building to be sent overseas. His customer must have been satisfied, because there followed many similar buildings sent to the same country. Of course, every metal structure is, by nature, prefabricated, and as early as 1807 an iron bridge, cast in sections in Coalbrookdale, was despatched to Jamaica. Similarly, in 1815, The Butterley Company exported a cast iron bridge which had been designed by Rennie, to India where it spanned the river Gomptee at Lucknow.

Perhaps the greatest demonstration of the advantages of mass production and prefabrication was presented by the construction of the Crystal Palace in which was housed the Great Exhibition of 1851. Here, on a grand scale, the processes of design, fabrication and erection were co-ordinated, allowing the whole structure to be completed in an extremely short time to the astonishment of the general public. Perhaps the mass production aspects of cast iron influenced the builders and would doubtless keep the cost down, but it is surprising that more wrought iron was not used. Even so, Prince Albert was so impressed that he ordered a prefabricated 'iron' ballroom which was duly erected at Balmoral.

The structural use of wrought iron was slow in development, largely because of its cost, relative to that of cast iron. Its tensile properties were certainly used to advantage in suspension bridges and quite a few, on a much smaller scale, were built before 1826 when Telford's Menai Bridge was opened. However, the impact of wrought iron was, in one respect, indirect in that its tensile strength made possible reliable boilers capable of higher pressures which, in turn, gave a great boost to the design and production of steam engines. Before long, in 1829, the locomotive steam engine made its entry and in the following thirty years, 7,500 miles of track were laid, viaducts helped to maintain reasonable gradients, bridges crossed innumerable rivers, roads and canals, and the mainline termini, the pride of the directors of the various railway companies, vied with each other in their grandeur. Here were the opportunities that architects, engineers and contractors had longed for and they rose to the challenge admirably. There are many small bridges, some with cast iron arches and others with wrought iron girders, most of them beautifully detailed, still in use and largely ignored. The more spectacular Britannia Bridge over the Menai Straits, although substantially re-built after a disastrous fire, and Brunel's Saltash Bridge over the Tamar still attract visitors from around the world and the magnificent arch of St Pancras station,

although completed later, in 1868, is one of wrought iron's masterpieces.

Because additional processes were involved in its manufacture, wrought iron was obviously more expensive than cast iron and there are some fine examples of structures where the qualities of both materials are used to the greatest advantage. Robert Stephenson's High Level Bridge at Newcastle, which was opened by Queen Victoria in 1849, is a true bowstring where the cast iron arch is restrained by a wrought iron tie. This is a truly innovative structure with two decks; the top, at the level of the crown of the arches carries the railway while the lower, at tie level, supports the road. About this time, cast iron began to be used in place of masonry piers, one of the best known being the Crumlin Viaduct, completed in 1857, which carried the railway at a height of 210 ft above river level. Wrought iron warren girders were supported by towers, each consisting of fourteen cast iron tubes 12 ins in diameter and 1 ins thick, cast in 17 ft lengths and braced vertically and horizontally where they connected. It also became common to build composite girders and trusses, where the tensile members were wrought and the compression members cast, which was not invariably a good idea since redundancy in design and inaccuracies in fabrication could lead to the development of completely unexpected stresses.

The subject of composite wrought and cast iron structures cannot be left without making mention of the many piers and jetties that were built around our coast. Both materials had excellent resistance to corrosion which made them eminently suitable for the purpose and a surprising number are still in use although the high cost of maintenance casts a shadow over their future.

The skills and experience of railway builders in this country were in demand all over the world and although the market at home declined after the initial 'Railway Mania' there were still vast opportunities for our structural fabricators in South America, Africa, Australia and particularly in India where nearly 1,500 miles of track had been laid by 1868. Although our own system was nearly complete, railways elsewhere continued to buy huge tonnages of 'railroad iron and steel' and our greatest railway contractor, Thomas Brassey, at one time employed 80,000 men in five continents.

Apart from the vast railway termini and exhibition halls, there are few records of interesting buildings and it is difficult to find out to what extent wrought iron was used industrially and commercially. Certainly the timber and cast iron beams of warehouses and multi-storey mills could be replaced by wrought iron but there seems to have been little innovation in the use of girders and trusses to provide factories of wider span; indeed, timber roofs, supported on masonry walls were still being constructed late in the nineteenth century. The reasons for the slow development of factories will perhaps be revealed as the happenings of later years emerge.

Design

The application of scientific principles to the design of structures was slow and fragmented. Even though so much work had been done by the mathematicians and 'natural philosophers' over a very long period, their work seems to have been bedevilled by jealousies, prejudice and lack of direction. Indeed it could be said that their studies were directed less towards solving practical problems than as examples of intellectual and

mathematical abstraction which is perhaps why valuable work was not immediately made available and put into use. Dr Hooke revealed his theories to the world in succinct Latin sentences, written in the form of anagrams which were hardly likely to have been the sole topic of conversation amongst aspiring artisans. Very much later, in the 1870s, Lord Rayleigh, himself a considerable scientist and academic, complained of Cambridge mathematicians that they "regard a display of analytical symbols as an object in itself rather than as a tool for the solution of scientific problems".

Writing in 1822, Tredgold, asserts that "The stability of a building is inversely proportional to the science of the builder" and a year or two later, W A Provis, Telford's right hand man, is said to have remarked that "an experiment is always more simple and satisfactory than theoretical deductions". It is popular to believe that the theorists and the pragmatists operated in isolation except to trade insults from time to time but, in reality, the practical, experienced people developed their own rules and, indeed, probably paid far more attention to the theorists than they cared to admit. Even so, in an age when communication was poor, scientific proofs which had no immediate application were soon forgotten or mislaid. What was lacking was the academic 'middle ground', people who could understand the practical problems of the engineer and who were also able to translate the rarefied work of the theoreticians into readily understandable formulae; but technical education was still some way off.

Compression could be handled reasonably well and the transition from masonry to cast iron was not too difficult. It is extraordinary to realise, however, that when wrought iron became available, with reliable tensile properties, the elastic theories were insufficiently advanced to allow a proper theoretical analysis, not just of trussed structures but also of simple beams. Fragments of the theory of elasticity had been propounded over a period of a hundred and fifty years before they were assembled by the French academics in the 1820s. Even then, it was thirty years before their work was accepted on this side of the channel and before Rankine gave us proper definitions of 'Stress' and 'Strain'.

With the advent of wrought iron, the engineers, at last, had a reliable tensile material, making possible long span suspension bridges which started to appear at the beginning of the nineteenth century. Whilst the statics of the designs seemed to be understood, it was clear that neither the dynamics of rolling loads nor of wind forces could be treated except by trial and error which led in many cases to serious damage and in others to spectacular collapse. Even Telford's renowned suspension bridge over the Menai Straits suffered severe gale damage from time to time, but before we criticise the adventurous engineers of those days, we should recall, with some humility, that as late as 1940, a newly designed suspension bridge crossing the Tacoma Narrows in the USA, failed through lack of aerodynamic understanding.

In practice, designs were cobbled together by a mixture of personal feeling, experience and testing, both of models and of full size structures. In 1822, Mr George Smart, extolling the virtues of his iron truss, tells us that "A model 8 ft to 10 ft long has been made and may be jumped upon without showing any movement". One wonders if this gave him sufficient confidence to start production.

The state of the art in the middle of the last century is set out in Edwin Clark's book, rather ponderously entitled "The Britannia and Conway Tubular Bridges with General Inquiries on Beams and on the Properties of Materials Used in Construction". He recounts that the Directors of the Chester and Holyhead Railway were impatient and "...with a degree of confidence in his (Stephenson's) purposes, which few shared with them, they instructed him to commence operations simultaneously at both Conway and the Menai Straits, leaving him to complete his design as he proceeded". Thus the massive stone columns of the Britannia Bridge were built considerably higher than the girders that they supported, which may appear to be an architectural device but was, in fact, an insurance against the possibility that the tubular girders may have needed suspension chains. The design was a mixture of experimental testing of models and the development of cast iron beam theory and it is surprising to read, thirty years after wrought iron became a structural material, Stephenson's somewhat ingenuous comment "...that this remarkable and unexpected fact was brought to light, viz that in such tubes the power of wrought iron to resist compression was much less than its power to resist tension, being exactly the reverse of that which holds with cast iron". In fact, the girders used in the Conway and Menai Bridges were designed by William Fairburn and Professor Eaton Hodgkinson, who both, in a practical way, made a great contribution to the art of design at that time.

Fairburn, however, for all his practical approach, was sufficiently astute to realise that education in this country was falling behind and after returning from the Paris Exhibition of 1855 he remarked "I firmly believe, from what I have seen, that the French and Germans are in advance of us in theoretical knowledge of the principles of the higher branches of industrial art, and I think that this arises from the greater facilities afforded by the institutions of those countries for instruction in chemical and mechanical science... ..Under the powerful stimulation of self-aggrandisement we have perseveringly advanced the quantity whilst other nations, less favoured and less bountifully supplied, have been studying, with much more care than ourselves, the numerous uses to which the material may be applied and are, in many cases, in advance of us in quality."

It appears that the design of latticed structures was in no better shape. The resolution of forces had been understood for two centuries or more and common sense would seem to dictate that simple triangulated configurations were appropriate, but the irrational arrangement of wrought iron diagonals in contemporary structures makes it clear that the problems of redundancy were not contemplated, perhaps because designers were not thinking in terms of elasticity. It is probable that a number of failures were caused by lack of accurate fit which could reverse the stresses in members, a particular hazard in cast iron struts and their connections. Naval Architects had, for centuries, had a much better 'feel' for trussed structures as the examination of the rigging of any substantial sailing ship will demonstrate, yet there seems to have been little co-operation between them and their brothers on dry land. The analysis of latticed structures only became possible in the 1850s and 60s but even then the methods were ponderous and time consuming. It was not until 1874 that R H Bow introduced his famous 'Notation' which gave the engineer a practical tool which he could understand and which quickly provided him with the load in each member. Methods that were then developed were used

until they were superseded by computers. Young designers who solve their problems today by the manipulation of a row of buttons are deprived of the euphoria of finding that, at the end of their labours, a complicated stress diagram neatly 'closes'.

It is fortunate that, at last, the fundamental principles of elastic design came together at the same time that steel came on the scene and made possible the giant steps forward that then took place.

So, as the end of the 1880s approached, everything was in place – skilled manpower, tools, workshops, improving education, a widening understanding of simple design, a material which was reliable and plentiful and, most important of all, a growing market both at home and abroad. It would be easy to imagine the cautious introduction of mild steel, gradually taking over from eighty years' experience of wrought iron but that was not the way in which it happened. Steel, in this country, made its entrance as the chosen material for what is, even by today's standards, one of the most remarkable metal structures that has so far been created – the Forth Bridge.

The Tay Bridge

Victorian self-confidence suffered a severe blow when the high centre portion of the Tay Bridge collapsed in a great storm at the end of 1879. There is nothing to add to the opinions already voiced as to the cause, or to be more accurate, the causes, for few aspects seem to have been above criticism. It is better to concentrate therefore on the good that came from it.

There was at once a re-examination of the parameters used in design, particularly wind pressures. Methods of manufacture came under scrutiny as well, but criticism of the materials was unfortunate insofar as the word 'iron' was used to describe both cast and wrought which in some minds raised doubts about both. Suffice it to say that when the bridge was re-built, starting in 1882, the new columns were of wrought iron and those original wrought iron girders that remained undamaged were incorporated in the new structure. Cast iron, on the other hand, rarely appeared again in the construction of bridges. Nevertheless, the confusion did no harm to the case of those who were strongly advocating the use of the new material, mild steel, which had only been approved by the Board of Trade a couple of years previously. What did emerge from the enquiry into the Tay Bridge collapse was the vital necessity of quality control at every stage from design through to completion on site; indeed control had to be further developed to cover all aspects of maintenance.

Perhaps the greatest good that came from the disaster was the cancellation of the contract to build a suspension bridge to carry the railway over the Forth. This had also been designed by Thomas Bouch, the engineer responsible for the Tay Bridge. Orders had been placed, including ten thousand tons of chains, and exploratory work started in 1879 with full public confidence in the scheme. But heavy rolling loads and suspension bridges had been found to be incompatible and the two 1600 ft spans may well have suffered the same fate as the high girders over the Tay.

The Forth Bridge

As it happened, the failure of the Tay Bridge made engineers even more determined to demonstrate their abilities, but it took an act of supreme confidence by the directors of the Forth Bridge Railway Company to go ahead so soon with the construction of what, at the time, was the biggest bridge in the world and, what is more, to agree to the use of open hearth mild steel, a material that had not previously been used for a bridge of any significance. The story of the design and construction of the Forth Bridge makes fascinating reading. Although the principle of cantilever bridges was well known, nothing on this scale had previously been attempted. There were no agreed safe stresses for mild steel, leading Benjamin Baker, who designed the bridge under the guidance of the chief engineer, Sir John Fowler, to carry out thorough tests on the material and establish the facts to his own satisfaction. In addition, Baker and Fowler devised and carried out a series of experiments designed to determine the likely maximum wind pressure to which the structure would be subjected. It is interesting here to observe that when Stephenson was responsible for the Britannia Bridge he used a theoretical wind pressure of 46 lb per square foot; Bouch, on the Tay Bridge, was advised that 10 lb was adequate

while from the researches of Fowler and Baker a figure of 50 lb emerged. In fact, the decision was ultimately taken out of their hands by the Board of Trade who, with the conservatism of civil servants, imposed a value of 56 lb, a nice round half-hundredweight.

Daring it may have been, but the designers did everything in their power to reduce the risk by detailed planning followed by the most rigorous control and inspection of all aspects as work progressed. In seven years, 55,000 tons of steel was brought to the site, fabricated and erected, and in the process, six and a half million rivets were driven.

The name of the contractor, William Arrol, who was knighted for his efforts, will be forever honoured by those who understand the magnitude of his achievement. Arrol, the fourth of a family of nine children was brought up in impoverished circumstances and served an apprenticeship as a blacksmith. Even though his early years were difficult and employment was hard to find, he managed to save enough to start his own business, making boilers, in 1868. Before long he added bridges to his repertoire and demonstrated such ability and ingenuity that expansion was extremely rapid. It is remarkable that only twelve years after building his factory at Dalmarnock, near Glasgow, Arrol was entrusted with a contract of such enormity, but it is even more surprising to discover that while engaged on building the Forth Bridge, Arrol also re-built the Tay Bridge and before either of these two huge structures was complete, work also started on Tower Bridge in London.

Sir William Arrol died in 1913, having created an organisation of enormous capability and reputation.

Corrosion

The development of steel was not without its problems. It was soon found that its resistance to corrosion was by no means as good as that of cast or wrought iron, largely, although it must sound contradictory, because it was too pure. Cast iron is really an alloy of iron and carbon; wrought iron contains silicon and in both cases some protection is obtained. Even so, all ferrous metal structures have been found to need some form of treatment to inhibit the ravages of oxidation.

Iron Bridge stood for a year or two without protection but was eventually coated with bitumen, which is almost certainly the oldest protective barrier coating. It was recommended by God, whose instructions to Noah were to "Make thee an ark of gopher wood ... pitch it within and without with pitch". More specific to the protection of iron is Pliny's report that a painter by the name of Nicias (320 BC) first used red lead. Later, in the first century AD there are references to iron being protected by a mixture of white lead, gypsum and pitch. Not a great deal of progress was made until the middle of the twentieth century, except perhaps for the dipping of sections in boiled linseed oil prior to painting.

No paint system has yet been invented that does not need repair and ultimate renewal. The fact that any large structure exposed to the elements needs constant attention has given birth to the cliché that any endeavour which appears to stretch endlessly into the future is 'Like painting the Forth Bridge'. Certainly it needed to be a continuous process but the care that went into the

original preparation and painting and the diligence of those responsible for its maintenance have, between them, preserved the structure in remarkably good condition after a hundred years of use.

The specification was quite simple. After careful cleaning, material was dipped in boiled linseed oil. It was then given a coat of red lead in linseed oil before erection. Then another coat of the same primer was applied and finally it received two coats of red oxide paint. It was simple but effective, and remained a system which did not change significantly until the early 1970s when British Rail banned the use of lead-based paints. The bridge continued to be hand prepared and painted using zinc phosphate based primers and undercoats until Railtrack took responsibility for its maintenance in 1994. By this time some of the paint could have been up to a hundred years old and it was decided to remove it in its entirety by abrasive blast cleaning before applying a completely new and highly sophisticated paint system.

Very little changed in the seventy years that followed the opening of the Forth Bridge. In spite of continuing research, nothing better than oil-based red lead paint emerged and it was widely specified. Only when steel was immersed in water or subject to high degrees of condensation was a coal tar pitch or bitumen based coating system commonly adopted.

Painting was not, however, the only method of protecting steel. The process of galvanising had been known since before steel came into common use, particularly for the protection of corrugated wrought iron sheets. After the material had been thoroughly cleaned, it was simply dipped into a bath of molten zinc which bonded to the steel surface, forming a coating that provided resistance to atmospheric corrosion even when scratched since chemically the zinc was attacked before the steel and could form a protective layer. It may seem surprising that the process was not more widely used but there was, of course, a cost penalty, not only in the process itself, but also in transport to and from the galvaniser. One other drawback to the process is that galvanised steel will not readily accept coats of paint because the surface is too smooth to provide a 'key'.

Origins of the Fabricators

In the 1880s there were many companies, large and small, who were able to fabricate steel structures and they came into being in a variety of ways. Some had been involved in metal manufacture since the earliest days. The Butterley Company, originally Benjamin Outram and Company, in which the famous engineer William Jessop was a partner, was founded in 1791 to mine coal, iron ore and limestone. Iron from their blast furnace was made into rails and pipes and sold widely in the local coal fields and to canals and waterworks. Experience in building cast iron canal bridges led the company to adventure into much larger projects and we find them engaged on Vauxhall Bridge over the Thames which opened in 1816. The company progressed and expanded into wrought iron manufacture, constructing many bridges and buildings in those materials including the magnificent arches of St Pancras station. When steel arrived on the scene they, and a handful of similar companies, were already fully equipped and experienced but time and trade cycles have taken their toll, leaving Butterley Engineering by 2003 as by far the oldest surviving fabricator of bridges and cranes.

The majority of companies, either directly or indirectly, could trace their origins to the blacksmith. Working with wrought iron, he was able to make all manner of ironmongery and agricultural equipment and it is not hard to imagine him progressing from a well made gate to a small roof truss or from a substantial ploughshare to hand riveting a few plates together to make a boiler. Some blacksmiths-turned-fabricators maintained a surprising versatility and could turn their hand to fulfil almost any requirement. Take, for example, the advertisement of William Fletcher early in the nineteenth century which tells us of his ability to produce 'Boilers, Clarifiers, Iron Boats, Evaporating Pans, Roofs, Grate Boilers, Gas Holders, Tanks and Smith's work in all its branches'. His son, Amos, continued the good work, adding 'Iron Girders of every description, Scoops, Purifiers, Screws and Cross Bars, Coke Barrows, Sugar Pans and Buckets'. These worthies were the ancestors of a long line of Fletchers, continuously and prominently involved in the structural steelwork industry.

Of course, there were some odd beginnings as well. It would seem unlikely that a statue founder would develop into a successful steelworker, but H Young and Co can claim, amongst many others, the steel frames of Harvey Nichols and Harrods and also the bronze Sphinxes on either side of Cleopatra's Needle.



Another point of entry was created by the steelmakers themselves. Because their plant was totally dependent on steam power, they had a continuing demand for new boilers and for repair and maintenance. Since the iron and steel making processes were continuous the capacity for immediate repair was vital and it was not prudent to rely on outside contractors. Every sizeable undertaking, consequently, included a 'boiler shop' on its premises, which although extremely busy from time to time, also suffered spells of comparative inactivity. It therefore became expedient to balance the load by carrying out building maintenance and, indeed, to manufacture new buildings and plant 'in house'. From this, it was a short step to becoming steelwork contractors to the outside world with the added advantage of providing a market for the steel that the company produced.

These were the roots of the industry, but it did not take long for skilled, ambitious men, trained and experienced elsewhere, to take the plunge and set up on their own. To make a start was not as difficult as may be supposed for simple equipment was readily available on the second hand market and rudimentary shelter not hard to find. This was, and to some extent still is,

one of the bugbears of the structural steelwork industry – inexpensive entry. Getting in was not too difficult; the art lay in staying in, despite the competition and the cyclical nature of both building and engineering. Few of the companies operating in 1900 survived to the end of the century and there have been very many others who have started and failed during the intervening years.

Factories and Electric Power

At the Great Exhibition of 1851, electrical machines were left out on the grounds, advanced by Brunel, that they were mere toys, yet the introduction of electricity, not many years later, had the most profound effect on the whole of industry and, indeed, became an enormous industry itself. At first, large companies used steam engines to generate their own electric power that was used to drive shafts and belts to individual machines. Fairly clumsy perhaps, but this represented a considerable increase in efficiency, as also, of course, did the ability to illuminate both workshops and offices. By the mid 1890s not only was power becoming available from both municipalities and private electricity companies but, also, individual motor drives came into general use making possible reliable, large span electric overhead travelling cranes, revolutionising the design of factories. In place of narrow brick buildings, supporting timber trusses and slated roofs, it was possible to build wide bays, independent of the surrounding walls, with good natural light provided by the recently developed 'Patent' glazing and with lifting capacity covering the whole floor area. There was the added bonus of flexibility in the positioning of machinery, which was no longer reliant upon runs of shafting.

Before the turn of the century, buildings of 75 ft span with lifting capacity of 50 tons were not uncommon but the dynamic loads of the cranes could no longer be sustained by brick walls and the fully framed workshop where all vertical and horizontal loads were carried by substantial steel columns had, at last, arrived. The impact of electricity and the flexibility it allowed on the workshop floor made it necessary to replace old factories in order to secure the greatest economic advantage and for manufacturers to retain their competitive position in the world. This process started slowly but gathered momentum at the end of the century although re-building factories for heavy industry, both financially and practically, was anything but easy. Industrialisation had been with us for a hundred and fifty years and companies which originally occupied valley bottom positions to take advantage of water power, like those which followed the River Don through Sheffield and Rotherham, had simply expanded on the same sites and had, in effect, become hemmed in, both physically and financially. It was too expensive to move, yet uneconomic to stay. Few companies had the opportunity or the resources to find new sites where they could take full advantage of new technology.



Industrial Architecture

The building of very much bigger factories, steel framed and clad with galvanised corrugated sheets, with nothing to soften their harsh and angular lines, produced an apparent incompatibility between efficiency and aesthetics. Traditionally, people had grown to accept that buildings were designed by architects and built of brick or stone, roofed mainly with slate or tile. Some industrial buildings of the time had texture and a little grace, particularly if the owners, like some of the prosperous Victorians and Edwardians, wished to make some public demonstration of their taste as much as of their wealth. Now, however, the engineer no longer needed the skills of the architect if all that was required was a purely functional building and, instead of rising to the challenge, the architects retreated to the styles of the past. What a pity that they were not persuaded by George Gilbert Scott who argued in 1858 that it was "...self evident that the triumph of modern metallic construction opens out a perfect new field for architectural development". Sadly, Scott himself quickly went off the boil and became the leader of Gothic revival.

Urban Buildings

Although the use of self-supporting steel frames became the norm for industrial buildings, there seems to have been reluctance, in this country at least, to take advantage of the benefits that could be gained in commercial use. Offices, hotels and shops continued to be built traditionally although steel beams made possible greater unobstructed floor space and their use as lintels opened up the ground floors and created the street scenes that we know today. In some ways it is surprising that the urban American experience was so different. They had far more space than European cities and it might have been supposed that there would have been less urgency to build vertically. However, they were the architects who developed the potential of the metal frame in high rise buildings.

Roebing and his work on the manufacture of wire rope has already been mentioned and he will doubtless crop up again because his ingenuity formed a springboard for a number of structural developments. Wire rope made possible the design, by Elisha Otis, of the passenger elevator in the 1850s which, in turn, made multi-storey buildings acceptable to the general public. However, the complete metal frame did not appear until the nine-storey Home Insurance Building in Chicago was erected in 1883. Wrought iron was still in vogue and it is only the four topmost storeys that were framed in steel, which soon became, and still remains, the preferred material for tall structures. Even so, the metal frame was not immediately or universally accepted and multi-storey buildings in Chicago continued, for a while, to

use load bearing walls, but as these approached seven feet in thickness at ground level, the supporters of the system conceded defeat.

Although the early American experience established the commercial potential of the steel skeleton, it was not to appear in Great Britain until Redpath Brown built what is generally regarded as the earliest frame in these islands. The event has been given various dates, descriptions and locations – a warehouse in West Hartlepool in 1896, a warehouse in Stockton on Tees in 1898 or, writing in 1967, the president of the BCSA, J D Bolckow, claimed that it was a Furniture Emporium in County Durham built in 1900. The confusion was caused because, in fact, there were two steel frames, the earlier one having been destroyed when the building was burned to the ground in 1899. Furniture Emporium was correct. Its location was Stockton on Tees and it was originally built in 1896. After the fire, the owners, Messrs M Robinson and Co could only see "...bare walls, tottering here and there, with steel supports and girders twisted into all kinds of crooked shapes", but with great energy they set about rebuilding their premises. This time they did their best to ensure that there would be no repetition of the disaster by installing sprinklers in every room, one thousand in all. Then, in an act that sounds like supreme bravado, they started a fire to make sure that the system worked! Before a large company of local dignitaries and the press, a huge bonfire of wood shavings and straw was set alight in the basement. Fortunately, as the flames reached the ceiling, the sprinklers opened "...in a manner very much alike unto a heavy thunder shower" and the fire was quickly extinguished.

If it is true that fashions are set in the capital city, then it is hardly surprising that steel framed buildings developed slowly. It was not until 1909 that London County Council acknowledged that the thickness of external walls might safely be reduced should a steel skeleton be introduced.

Section Books

Dorman Long produced their first section book in 1887, setting out the properties of all the profiles that they rolled at that time including beams up to 18 ins deep. Others followed, although there was no standard applicable and each company rolled sections which it considered the most saleable. Some time later, a number of fabricators also produced books of section tables incorporating all manner of useful data. Before any sort of standard or regulation appeared, these were the sources of design information and contained recommendations on stresses, factors of safety and loadings for various categories of buildings as well as formulae for the design of beams and columns. Roof trusses, compound beams and columns with safe loads over a range of spans and heights, wind pressures, details of sheeting and glazing and the design of gutters and downpipes all were included as people vied with each other to put together the most sought after handbook which would keep their name before the architects and engineers in whose hands lay the appointment of contractors.

Bridges

The 1890s saw the end of wrought iron as a structural material. Steel, made by the basic open-hearth process, had replaced it, quite painlessly so far as the fabricators were concerned. Their prospects looked bright; there were many factories to replace; developing manufacturing processes required structures and workshops, and the demand from overseas was undiminished.

The railway system in Great Britain was nearing completion before steel came on the scene. There were, of course, some exceptional bridges constructed in this period, crossing the Forth and the Tay, and there were still a number of less prominent bridges to be built or re-built and a few urban lines to complete, but these were 'tidying-up' operations, small, in total, compared with the booming days of railway construction. However, the same was not the case overseas where, in every continent, railways had a great deal of development ahead of them. Particularly in India, many thousands of miles of track still remained to be laid and, as might be expected in a country with a very heavy and concentrated rainfall, there were many wide rivers and deep gorges to be crossed, providing a vast market for steel bridges in which most of the substantial British fabricators became involved. To add scale to the size of the rivers and flood plains, the Godivari Bridge, which was built by Butterley in the late 1890s, included 56 spans of 150 ft in a total length of a mile and three quarters.

Back in England, between 1887 and 1894, one of the most ambitious civil engineering projects was carried out in the construction of the Manchester Ship Canal where the entrance lock was 600 ft long and 80 ft wide to allow the passage of ocean going ships. Railways, roads and the Bridgewater canal lay across the chosen route, all of which were eventually carried by steel bridges. The main-line railways could not tolerate any restrictions on the flow of traffic and were elevated on embankments before crossing the canal. Roads spanned the canal on robust swing bridges which worked perfectly but were sadly not designed with the rapid increase of motor traffic in mind, causing endless frustration until they were supplemented by high level motorway crossings. The Bridgewater canal produced a unique solution where a complete section contained within a steel swing bridge could be isolated and rotated to let the larger ships pass. Although the ship canal is now little used, all its hundred years old steel bridges still seem to be functioning as well as ever.

All, that is, except the famous, or infamous if you happened to be a motorist in the 1950s, Runcorn Transporter Bridge which, much to the dismay of a number of preservation societies, was demolished fifty years after it was built. Already, in the early years of the century, the rapid expansion in the use of motor cars could have been predicted but in 1905 this 1000 ft suspension bridge, spanning both the Mersey and the Ship Canal, was sadly only capable of carrying a couple of dozen vehicles at a time on its suspended platform.

In the records of steel structures built in these years, the emphasis seems to be very much on bridges. This is understandable, up to a point, because complete steel skeletons had yet to become fashionable. It is unfortunate that industrial buildings received so little attention and are not well recorded. They, after all, became the bread and butter of the steelwork contractor and deserve far more attention.

Towers and Wheels

There was, however, one group of steel structures, which was hard to categorise – leisure complexes, perhaps? To some who visited Paris in 1889 it became a matter of national prestige that we should build something bigger than the Eiffel Tower.

Sir Edward Watkin set up the Metropolitan Tower Construction Co in 1889 with the intention of building at Wembley a tower 150ft taller than that in Paris. A competition was held to find the most appropriate design that produced some extraordinary entries. Some were bizarre but one in particular was well ahead of its time insofar as it was cable stayed and looked as though it might well have been the work of a naval architect. The chosen design was more conventional but, sadly, when it had reached a height of 155 ft the gods of finance intervened and the whole project was abandoned. And some might say it was just as well, since, otherwise, international rivalry might have led to both countries surrounding their capital cities with a series of increasingly tall structures. What is really amazing is that anyone would have the confidence to embark on such a huge project when, apparently, only a very small proportion of the necessary capital had been raised.

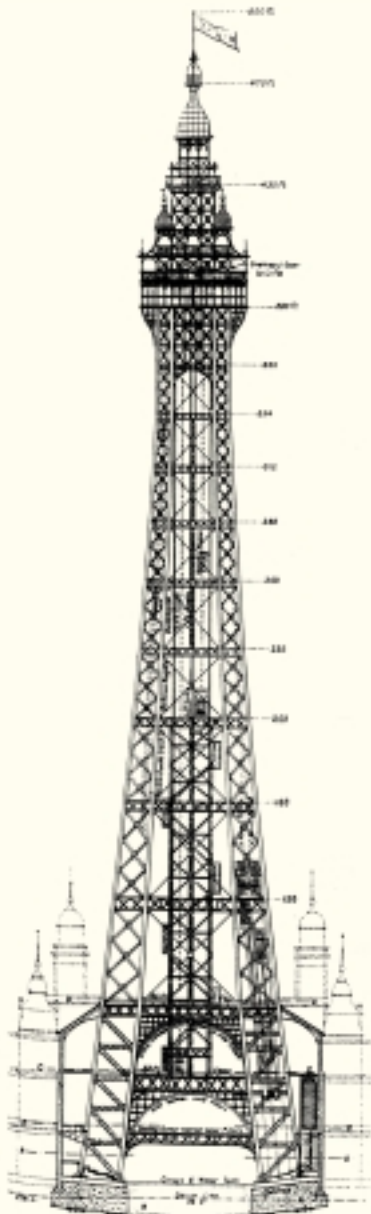

Next we hear of the Standard Contract and Debenture Corporation, which conceived the idea of promoting the building of towers at northern seaside resorts. The financial juggling would take a great deal of unravelling but one or two were started and quickly went the way of Wembley before success was achieved at Blackpool. The original company had moved on and the scheme was carried out by the Blackpool Tower Company, driven by Sir John Bickerstaffe, who at the time was Mayor of the Borough. It was his enthusiasm and determination that persuaded the public into investing sufficient capital. In May 1894 the second tallest building in the world was opened to the public who were hauled 500 ft up to the viewing platform in a lift made by the company founded by Elijah Otis. Not much above half the height of the Eiffel tower and lacking its grace, Blackpool Tower has, nevertheless, basked in the affection of the public ever since. Of course, it was not just a tower since the base area was used for all manner of public attractions including an aquarium, a menagerie, the world famous Ballroom, the immensely popular Tower Circus and an endless complement of bars and restaurants. Compared with 7,000 tons of wrought iron in the Eiffel tower, Blackpool contains 2,500 tons of steel and a further 1,000 tons in the structures that surround its base.

Judging that Blackpool had created something that brought prestige to the town and, at the same time, commercial success, New Brighton decided that it, too, would have a tower. Very quickly a team was assembled to design and build an octagonal structure, 75 ft taller than Blackpool, and it must be said, judging from contemporary pictures, rather better looking. It was opened in 1898 after a certain amount of wrangling between customer and architect and a number of delays in getting the plans accepted by the local council. Unfortunately, it never achieved the popularity that would have ensured its financial success and, after years of neglect, it was judged to be unsafe and a demolition order was issued in 1919.

It seemed that people enjoyed the sensation of being hoisted into the air to admire the view and competition for their favours soon appeared when the Blackpool Gigantic Wheel Co was registered in 1896. Work started at once on a wheel which was 220 ft in diameter. The 26 ins steel axle was 48 ft long and weighed 30 tons, but how it was hoisted to its position 110 ft above the ground, is not revealed to us. The best part of a thousand tons of structural steelwork went into the Big Wheel which made four revolutions per hour. But the motion was reported to be jerky and the view did not compare with that from the tower so, after languishing in unpopularity for twenty years, it was sold for scrap. Even then, misfortune followed, and it was found that the cost of dismantling was greater than the value of the material.

It cannot be said that the last fifteen years of the nineteenth century was a period of continuous economic prosperity. However, neither were trade cycles as extreme as they had been, nor unemployment as severe or as long lasting. Demands for steel increased both at home and abroad, shipbuilding enjoyed some good years and the steel makers earned a little respite from the uncertainties of the previous decade but, although our national production increased, its proportion of world output continued to decline as we were overtaken by both Germany and the USA.

Society was not totally devoid of social conscience. The first hesitant steps were taken in legislation to provide education for those who could not afford to pay, to prevent the worst abuses of child labour and to provide compensation for employees killed or injured at work, but seemingly nothing could be done to regulate the continuing trade cycles which were the root cause of so many industrial disputes. After a hundred and fifty years of industrialisation we were no nearer to finding an answer to the problems in the relationship between employer and employee.

So the century ended with many problems but with some hope and with one certainty – the structural steelwork industry was firmly established with a proven capability for the design and fabrication of contracts large and small, anywhere in the world.

CHAPTER 3 – 1900 TO 1910

A New Century

The new century opened with a decade of progress – social, political, technical, commercial and industrial.

At last, realisation dawned that further education in the UK was lagging behind its international competitors and in 1902 an act was passed, handing both elementary and higher education to the County Councils and County Boroughs. This reform greatly increased the numbers of those in secondary schools and made it possible for students of small means to reach the universities.

The activities of organised labour focused on the political scene. The 1906 general election resulted in a victory for the Liberals who had campaigned on a policy of social reform. Also, for the first time, a sufficient number of Labour MPs were in place to maintain pressure for the fulfilment of electoral promises which came gradually and not without some obstruction. It seems that progress was allowed just sufficient pace to counter the militants' vision of workers' control, both of industry and ultimately of government itself. Most significant to the trades unions was the Trades Disputes Act which protected their funds from liability for actions which had hitherto been regarded as 'civil conspiracy'. There were also a number of acts which were of great benefit to the public at large, and which formed the first steps towards the welfare state. School meals, the setting up of Labour Exchanges, relief for the unemployed, school medical inspections and old age pensions all had their origins in the years between 1906 and 1910.

Steel Making

It is always difficult to determine the state of trade in the overall since accounts are biased towards the particular interest of the reporter. What to some industries is a slump may not affect others to anything like the same degree. However, a hiccup in any other sector always seems to lead to a downturn at the heavier end of industry, largely because companies quickly take fright and cut back on capital investment whether it be in buildings or machinery. And the immediate repercussion is felt in the iron and steel industry which is basic to practically any development. In exactly the same way, that section of the construction industry which concerns itself with industrial and commercial building is equally vulnerable.

Technical improvements in steel making had substantially increased production, indeed there was a growing over capacity in the industry which was also suffering from the advance in steel production in some of the traditional overseas markets. Nor were our manufacturers helped by the free trading stance of government which allowed the dumping of surplus production by countries which, at the same time, were beginning to erect tariff barriers to protect themselves. Austin Chamberlain's unofficial Tariff Report of 1904, which was strongly supported by the steel industry, suggested tariffs of between 5 and 10 per cent, but it was many years before any action was taken. The steel makers had to do the best they could in conditions of perpetual fierce competition and to some extent worked together to stabilise prices. They also opened fabricating shops of their own as an outlet for their steel. Dorman Long's structural shops opened around 1900 and over the next seventy years, by expansion and amalgamation, the company's output grew

enormously. Frodingham also ventured in this direction in 1904 and many others set up simple fabricating facilities to sell both to general contractors and to the structural engineering industry. Subletting items like purlins and the internal members of roof trusses to the rolling mills, at knock down prices, became common practice, much to the bewilderment of the customer who, not infrequently, found that bulk deliveries from the mills, totally out of sequence and often unannounced, created havoc on site.

Of course the actions of the steel mills were closely watched by the fabricators because they knew that in spite of vociferous protests to the contrary, the mills were selling simple fabrication at cut prices directly to the general contractors. Equally, the mills knew that in spite of vigorous denials, the fabricators were, at times, buying steel from abroad. In fact this stand-off sufficed to keep both parties more or less in line with only occasional transgressions. There was, nevertheless, a deep rooted suspicion, which persisted until the 1980s when the steel industry finally sold off its fabricating capacity, that competition was unfair because, it was claimed, those companies which were owned by the steel mills received their materials at a considerable discount.



The Fabricating Industry

More than most industries, the fabricators suffered from the peaks and troughs of trade cycles and in the interest of efficiency, most of them reduced their 'all things to all men' approach and concentrated on one or another aspect of the trade. Some took to process plant, others to more mechanical aspects like crane making and materials handling, while some, who had started as boilermakers and developed into structural fabricators, decided that there was more profit in their first occupation and went back to it. Most hankered after some line of business that would give long production runs, or which would give them some unique specialisation in order to sustain their output when trade was slack. Many and various were the answers that they found. Handrails, flooring, platforms and staircases, architectural steelwork, storage tanks for the growing oil industry, fencing, and railway wagons are just some of the allied products that were adopted. Even so, most of these were also subject to the vagaries of trade and were dependent on capital expenditure. Thus their cushioning effect was not, in many cases, as great as might have been hoped. The simple truth was that there were far too many companies competing in the structural fabrication industry. The decline in the use of cast iron and wrought iron naturally led foundries and forges into the use

of steel, with varying degrees of efficiency and not, in the overall, with much success. The effect, however, of only a small number of competitors who were short of work or, as has frequently been the case, were not aware of their own costs, was to drive the pricing structure of the whole market downwards.

Trade Associations

Against this background the fabricators found it very hard to make a living. Not only did they suffer the self-inflicted wounds of under-pricing their work to meet the fierce competition, they also found themselves, more often than not, in the position of sub contractor with the attendant hazards of 'Dutch auctioning', a device used by many main contractors to achieve rock bottom prices. To add to their woes, some of the main contractors were notoriously slow payers while a few proved to be unstable and in the event of their failure, the fabricator suffered a financial loss with no redress.

Observing that the steel makers were benefiting from co-operation, involving some degree of price fixing, and that labour rates were fairly consistent across the industry, the fabricators made tentative moves towards creating an organisation for their protection. In 1906, five of the larger fabricators in the Manchester area put their heads together and, two years later, the Steelworks Society was formed, initially with eight members. The impact was not immediate since there were many competing firms outside the Society, but gradually these people found that membership was to their advantage and thirty years later the organisation could muster a total of forty companies in the Northern Counties. Similar groups formed in other regions of the country, ultimately to be amalgamated into The British Constructional Steelwork Association in 1936.

The minutes of the early meetings of the Society are anything but revealing. The only thing regularly and accurately reported is the passing for payment of stationery and postage charges, which is hardly an accurate measure of their activity. The substance of the meetings is only hinted at and it is clear that the members were uncertain of their legal position to the extent of giving themselves code names and numbers. Reading between the lines, it would seem that their activities were fairly harmless, concerned mainly with exchange of information about wage rates and conditions and discussion on the effect of various pieces of legislation. Clearly, meeting and getting to know each other helped them to exchange small favours, but such arrangements were obviously outside the official business.

Over the years there has been a great deal of controversy over the activities of powerful trade associations. Taking the best view, they provide a forum where each member can express his views and where both practical and commercial matters of common interest can be discussed. They can sometimes provide a regulatory mechanism which reduces suicidal competition and thus prevents the severe damage that can be brought upon both shareholders and employees. And, most importantly, they are the voice of the industry in negotiations with similar organisations and with government. The opposite belief is that they are simply a crude attempt to establish a cartel to fix prices and overcharge the customer, at the same time combining to regulate wages and deprive their workpeople of their just rewards. In so doing, there is no incentive to improve efficiency or to further technical progress.

Neither, of course, is the case; the true nature of such organisations lies somewhere in between but, dependent upon the membership at any particular time, the emphasis can swing one way or the other. How, in practice, the members of the BCSA conducted themselves over the years will hopefully be revealed in later chapters.

Design and Standards

In the first years of the century, design was left very much to the discretion and skill of the engineer or architect. There were no universally agreed permissible stresses or factors of safety, nor were design methods in any way mandatory. Reliance was placed entirely upon the integrity of the designer and it must be said that this confidence was very seldom misplaced. The incidence of collapse was rare and, as throughout the history of metal construction, the period of instability during construction was by far the most hazardous time. Nevertheless, when submitted to modern methods of analysis, some old designs, particularly the connections between members, have been found wanting, but the understandable ignorance of those responsible remains hidden by the factors of safety and by the forgiving nature of a ductile material.

The use of steel in buildings of all descriptions expanded rapidly. Industrially, where the architect was infrequently involved, it became customary for the fabricator to design the steelwork and even in situations where an architect had been engaged the fabricator was frequently called upon to produce a design with his tender. This was clearly uneconomical, but most companies maintained the view that their own designs were conditioned by their fabricating equipment and methods and were thus more likely to bring success in competition.

The first steps towards regulation came with the foundation of the British Standards Institution. Between 1900 and 1906, BS 1, BS 4, and BS 15 were issued and periodically up-dated, ensuring that structural designers had at their disposal an agreed range of sections of a clearly defined quality.

The first regulations controlling design came in the London County Council (General Powers) Act of 1909 which gave detailed rules on permissible stress and loading and also, very significantly, made it lawful to erect '...buildings wherein the loads and stresses are transmitted through each storey to the foundations by a skeleton framework of metal...'

Local by-laws followed in other parts of the country and although few were specific in the regulation of steel construction, reference could be made to the London Act which, in effect, set a national standard although some of the larger cities maintained some independence. At last, the many advantages of steel frames could be demonstrated and, from that time, they gradually increased in popularity in the home market.

In other parts of the world, the experience of American contractors had already found favour. The firm of Milliken Brothers, for example, pioneered the development of the steel skeleton in South Africa and enjoyed a few successful years until Dorman Long opened an office in Cape Town in 1903 and together with a handful of British fabricators soon dominated the market in that country.

Industrial Structures

It is interesting to consider the different approach to industrial and commercial buildings. While the steel skeleton, as we have seen, was slow in acceptance, there are a number of industrial examples where the frame acts in the same way but yet seems to have been put into use without comment. In 1903, Arrol completed a multi-storey storage building at Guinness's Brewery which was 116 ft high and about 150 ft square in plan with built-up rectangular columns, plate girders and in-fill joists. It must be admitted that the method of design is not known, but from its appearance, the structure seems to be robustly self supporting.



The ship building industry had, as usual, peaks and troughs, although it was extremely busy in the middle years of the decade. In 1906, Great Britain and Ireland launched 886 ships over one hundred tons amounting to a gross tonnage of 1,828,343 which was not far short of two thirds of the world's output. Confidence must have remained high for there was heavy capital investment in the industry, not only in slipways but also in all the ancillaries. Large and well equipped factories were designed to make engines and boilers as well as the guns of naval vessels.

Here, however, is an extraordinary anomaly; whilst massive factories with heavy cranes were being successfully built in one part of the country, there seems to have been an inability to meet the customer's requirement in others. The British Westinghouse Electric and Manufacturing Co chose to build a factory at Trafford Park, Manchester and, unlike most British enterprises which had simply grown from some modest beginning, here was an immense new integrated facility. It is reported that the local foundation contractor and the London steelwork contractor both believed that it would take five years to bring the plant into operation, which was hardly music to the ears of Messrs Westinghouse. They promptly engaged James C Steward, a Canadian with a reputation for making things happen. He arrived in 1901, with a team of assistants, and introduced new methods and new thinking to such effect that eight out of the ten buildings were in use within ten months. Without wishing to detract from Mr Steward's achievements, it must be said that if, perhaps, more care had been taken in selecting the original contractors, the story might have been rather different.

At the same time, it has to be admitted that new industries were met with some caution by British manufacturers. As bicycles and motor-cycles progressed to motor cars, production developed and workshops were modified or extended to cater for foreseeable needs. Herbert Austin, we have always been led to believe, moved to Longbridge in 1905 to take advantage of a green-field site but it is very surprising to find that, in fact, he moved to a derelict printing works. About the same time, the Daimler Co was set up in a converted mill in Coventry. Rolls Royce, when they moved to Derby, at least developed a purpose built factory, but in spite of the company's prosperity and insistence on mechanical perfection, it still economised over the appointment of an architect. Henry Royce wrote in 1907 that "...it would be quite unnecessary to employ an architect to prepare drawings, or to supervise erection of buildings, as Messrs Handyside are engaged and have for some years been engaged in erecting buildings of a similar nature".

But the architect who had been abandoned by the irregular and intricate process buildings of industry had an opportunity to make his mark in the construction of power stations. Early examples were built as close as possible to centres of population and, to satisfy civic pride, attempts were made to design an envelope that had some style. There was, perhaps, a consciousness of the florid detailing of Victorian and Edwardian pumping stations but electricity generation demanded buildings on a vastly different scale. Of course, like any other architectural endeavour, there are good and bad examples, depending very often on the interest and the taste of the employer. Certainly a most difficult subject but some were so successfully handled that, although the huge buildings no longer generate electricity, they have become national monuments.

Urban Buildings

It is not easy to define what exactly constitutes a steel framed building as, for many years framing was hybrid such that wrought iron beams, later replaced by steel, were used to span between load bearing walls. This system was followed by columns supporting a grid of beams, and this fully steel-framed arrangement allowed much greater latitude in the arrangement of partition walls since they had no longer to be vertically continuous. At this stage, all horizontal forces had, because of the restrictions of building codes, to be carried by external walls and it was not until 1909 that the steel skeleton, sustaining both vertical and horizontal loads, was permitted.



Here the trap is set of describing any particular building as "the first" of its type. It really does not matter unless the structure had such an impact as to set going a completely new trend. The Ritz hotel in London is often quoted but in 1906 it would not have been permitted to act as a complete steel skeleton. It must

therefore be said that there were a good many steel framed buildings in various British cities which pre-dated it. A good example is the Midland Hotel in Manchester built in 1903. It absorbed 2,000 tons of steelwork fabricated by Edward Wood including some girders weighing in at thirty tons. One of the intriguing things about this contract is that it was driven by our old friend James C Steward who had stirred up the building of the Westinghouse factory. He followed this by organising the building of the Savoy hotel in London which in 1904 contained a similar tonnage, this time fabricated by Dorman Long.

Bridges

Growth in the use of steel was not confined to commercial and industrial buildings. Bridge design took advantage of the possibilities offered by the material both at home and abroad.

Our railway system had been developing for seventy years or more and the volume of traffic was vastly greater than could ever have been anticipated. Some bridges were found to be structurally inadequate and had to be replaced completely while others were seriously in need of widening to take additional tracks. The reconstruction of Central Station, Glasgow required that the original wrought iron bridge over the Clyde had to be supplemented by a new structure carrying an additional nine lines. Although of economical design, crossing the river and two adjacent roads consumed eleven thousand tons of steel – in other words, one fifth of the weight of the Forth Bridge!

The process of extending and improving the railway system continued and although there were not many new bridges of any lasting fame, there were plenty which were substantial, workmanlike and well designed and which, nearly a hundred years later, are still in continuous use with a long life ahead of them.

Two fine examples can be found in the north east where the King Edward Bridge, built by Cleveland Bridge and opened in 1906, used nearly six thousand tons of steel to carry the railway over the river Tyne.

Three years later and not far away in Sunderland, a two-tier bridge was opened carrying road and rail over the Wear. Arrol's engineers drew on their experience on the Forth Bridge, cantilevering the centre span out from both sides and using, in the process, eight hundred and fifty tons of steel in falsework alone, which was one tenth of the finished weight of the bridge.

It was uncommon to find a local authority with the foresight to use a rail bridge to support a road but, of course, there was the splendid example nearby of Robert Stephenson's bridge in Newcastle. The growth in road traffic was not foreseen – perhaps it was assumed that people would only travel short distances by car and continue to make longer journeys by rail. Whatever the reason, the fact remains that the road system in this country continued to use routes laid out by the Romans with very little improvement for another fifty years.

There was still an excellent trade in exporting steel bridges to many parts of the world. Indian railways seemed to have had an insatiable appetite which kept a number of fabricators busy. It must be remembered that the wealth of experience in railway building that had been accumulated in the British Isles was in great demand abroad and the skill and integrity of our consulting engineers led to appointments of many years duration on complete railway systems. Not only were their

accomplishments formidable, they also helped to create a market for British suppliers. Nor was the trade entirely one way; some consultants earned commissions from the bridge builders themselves when they were called upon to compete for design and build contracts.

Sir Charles Fox was, in his early days, a pupil of Robert Stephenson, and later achieved fame through his company, Fox Henderson, as the manufacturers of the Crystal Palace in 1850. Later he set up as a consultant and won many contracts overseas. He was followed by his son, Sir Douglas Fox, who further expanded the volume of work, becoming the engineer on many African Railways which led to his appointment with Sir Charles Metcalf, one of his partners, as engineer for the famous bridge over the Zambezi at Victoria Falls. Here was a bridge site that was as dramatic as could be imagined but it was clear that construction was going to be singularly difficult. Not the least of the hazards was that spray boiling up from the falls for six months in the year meant that everything on site, men, material and machinery, was permanently saturated. A start was made by firing a rocket over the gap, carrying a light line which was gradually increased in size until a substantial 'Blondin' wire stretched across the gap, supporting a ten ton electric lifting block which not only carried out all the work but also ferried men from one side to the other.

A triumph for Cleveland Bridge, but one wonders whether perhaps they found the fame a little expensive at a price reputed to be seventeen pounds per ton delivered and erected on site!

The design was carried out, under the supervision of the partners, by a young man by the name of Ralph Freeman who later achieved fame as the designer of the Sydney Harbour Bridge.

Another overseas bridge that is worthy of mention carries the road from Cairo to Ghizeh over the river Nile. Won in international competition, this bridge was built to their own design by a joint venture of Arrol and Head Wrightson. Undramatic, and in the present day fury of traffic almost unnoticed, the eight thousand tons of steel and the electrically operated swing span still provide an essential river crossing.

By 1910 the structural steel industry was flourishing. Standards had been set, methods of design, if not radically improved, had at least been clearly defined and the education of engineers was steadily moving forward. Workshop methods remained more or less the same as they had been for a good number of years although here and there a well designed, purpose built factory was to be found.

Of course, like any other industry, there were peaks and troughs although conditions varied in different parts of the country. In spite of the excellence of the railway system, work was carried out on a much more local basis as is evidenced by the operation of the various trade associations. The Steelwork Society in Manchester, for example, debated whether it should increase its 'catchment area' from a radius of thirty five to forty miles.

In the short period of the Steelwork Society's existence up to 1910, there is little mention of labour disputes although the latter years of the decade were marked by frustration and disappointment that the optimism and promise of social legislation and a liberal regime had not been fulfilled. Indeed, costs had risen and the working population in general found that living standards had deteriorated.

A Decade of Disputes

In the years immediately before the Great War of 1914-18, industry prospered, unemployment fell and yet it was a period of industrial turmoil and unrest. Working people were aware that their living standards did not improve, indeed, in not a few cases they actually fell, and over-optimism in the previous decade produced a reaction of militancy, directed not only at the employers and government but also at trades union leaders who were perceived to have become remote and compromising

Some of the biggest and most bitter strikes that the country had yet seen took place in this period. The dockers and seamen in 1911 achieved some success, as did the miners in 1912 after a strike involving more than a million workers. Thus encouraged, and strengthening by amalgamation and by agreements for mutual support, trades unions played a much stronger hand.

Employers were alarmed at this tendency and the more liberal and far sighted realised that if no movement took place, there would be a wholesale challenge to the country's institutions. A number of trades union leaders joined with some prominent employers to establish a National Industrial Council which, unfortunately, was unsuccessful in calming the industrial relations scene simply because it had no power. It was, nevertheless, the first attempt to create a framework in which disputes could be resolved.

Trades Unions

The trades union movement, internationally, was pacifist, arguing that all wars were capitalist wars and that whatever the outcome, ordinary working people stood to gain nothing. In the event, however, the apparently powerful unions of Germany, France and Britain were unable to prevent the outbreak of hostilities in 1914 but, once engaged, the labour movement in this country accepted that it had to play its part and made great efforts to co-operate. Within a year the government had to ask the trades unions to relinquish, for the duration of hostilities, the entire network of conditions, practices and restrictions that had been built up and accepted over many years. Additionally, so many skilled men had joined the forces that it became necessary to up-grade unskilled personnel to do their jobs. All this the trades unions accepted but the turmoil led to the rapid development of the shop stewards movement.

Originally they were minor officials appointed by employees in a particular workshop and charged with the duty of seeing that all union contributions were paid and accounted for. But the wartime changes in practices had to be negotiated at workshop level and were far too numerous to be dealt with by the full time officials who had adopted a responsible position and were far too busy attempting to avoid damaging disputes. Thus, militant shop stewards gained a power and importance that they did not relinquish when hostilities ended.

The Trade Associations

Companies, who had first made moves towards forming a society for their mutual benefit, were slow to organise themselves and it was 1910 before any real activity took place, indeed, the name 'The Steelwork Society' of the first group only officially came into being in 1911 when the rules and by-laws were finally agreed by the original members. They were clearly a little uncertain about their position because their minutes record that each company was given a pseudonym "In order to entail more secrecy". In fact, these code names were not used since they found that the numbers they had allocated were adequate.

In essence, the group collected information about tender lists and where it was found that there were no outsiders, a tender fee of one quarter of one percent was added, to be paid by the successful tenderer into the kitty. Obviously, all orders had also to be reported. Although there was still a number of companies who either were not invited to, or would not join, it seems that the system worked tolerably well, judging, at least, from the sums of money that accumulated. Their activities did not pass unnoticed by similar companies in other parts of the country leading to the establishment of the London Constructional Engineers Association in 1913 whose members were desperate to raise their prices and who complained that their work was too competitive and unremunerative. The figures quoted, which it must be admitted are hard to believe, are that in the twelve years up to 1912, the average price of steel was £5.075 per ton, and the selling price of fabricated work was £5.90, leaving 82.5 pence for workmanship, overheads and delivery.

Because of the intervention of the war, this group was comparatively inactive for some years but it did try to set up a standard form of contract, which got to the stage of being drafted by solicitors although there is no evidence that it was ever put into operation.

In 1919, nine companies in the Birmingham area, set up the Midlands Association on similar lines to the others, reporting enquiries and orders. It was obvious that three separate organisations working in isolation would cause all manner of problems and some degree of co-ordination was necessary. The London group arranged joint meetings with the other two which was the embryo from which grew The British Constructional Steelwork Association.

The regional groups continued to discuss amongst themselves the problems of wage rates and conditions and there is occasional mention of disputes. Certainly they all had a difficult time in 1917 and 1918 when they came under pressure from the unions and when wage increases could only be authorised by the Ministry of Munitions.

Steel Structures

The whole construction industry and the shipyards were certainly busy as the Government of the day prepared for a war, which was thought to be inevitable.

As might be expected, industrial building, the main stay of the fabricators, provided a heavy workload, but the methods of design and construction changed little. This was the age of the roof truss in its various forms which were used in a small

number of different configurations, some, it must be said, with flair and ingenuity but it was seldom that an industrial building warranted more than a passing glance except to remark that new installations were on an ever increasing scale.

Not only were individual factories much bigger, but also there was a movement towards grouping them together and separating them from areas of housing. This was not necessarily a town planning decision, but a commercial development that offered an estate with all services and good communications by road and rail. One of the trend setters, which had the additional advantage of access to the Manchester Ship Canal, was Trafford Park, which started in the early years of the century, and the wide variety of industries which established themselves there had covered an area of six hundred acres by 1920.



Power stations were constructed where the need arose, very often in urban situations to reduce the cost of power transmission. Half of them were built and owned by local authorities, and the other half by private companies. Unfortunately there was no agreement on standardisation of current, voltage or frequency which brought about a strong movement for a central authority. The Electricity Supply Act of 1919 established the Electricity Commission with the duty of 'promoting, regulating and supervising the supply of electricity'. Like so many government sponsored bodies, it had inadequate power and could only act by persuasion. In the meantime the size of power stations continued to grow as did the weight of the individual structural members needed to support much heavier plant. This, in effect, reduced to just a handful those fabricators who had sufficient muscle to handle contracts of ever increasing complexity.

Even before the London Building Act of 1909, steel frames had grown in popularity. Selfridges, in 1906, which, surprisingly, in view of the complaints of the London fabricators, had a delivered price of £8 per ton, the Waldorf hotel in the same year and the Morning Post building in 1907 had all contained a large tonnage of steel. The Royal Automobile Club of 1911 was a little unlucky insofar as it had been started before the 1909 act and could not therefore be a complete steel frame. The same could be said of the Calico Printers Association building in Oxford Street, Manchester which was also erected about 1911, but it did have the distinction of being one of the earliest buildings with hollow tile floors.



One of the best-known buildings to take advantage of the relaxation of the 1909 act was Kodak House in Kingsway, designed by Sir John Burnet and built in 1910. This was the forerunner of many office buildings and shops of ever increasing size. Australia House in the Strand, Portland House in Tothill Street and several office blocks in Westminster, Pall Mall and Oxford Street were built before the outbreak of war as well as similar structures in the provinces. In fact, in a very short space of time, the steel frame had developed and was in general use as an economical and practical method of building.

On old photographs of large urban structures during construction, there always seems to be a number of Scotch Derrick cranes perched, apparently precariously, on the bare steel frame for although the Americans, with much greater experience of this type of structure, invariably used a guyed boom derrick, this piece of equipment never became popular over here. This, in spite of the example set in the construction of the Ritz hotel in 1904 when Sven Bylander had one specially imported, along with American erectors, to demonstrate the system.



Rigid frames were used occasionally, but not in the sense of the careful calculations that are made today. Methods of analysis did exist, but were so onerous that they were, in general, replaced by simplifying assumptions. This was also the case in column and beam buildings where beams were designed as though they were simply supported, but the moments generated by the connections to the columns with top and bottom cleats were considered to provide sufficient horizontal stability.

Fire Regulations

When buildings were constructed of wood and the only means of heating them was by open fire, even minor accidents could lead to the total destruction of a complete neighbourhood. Local by-laws attempted to reduce the risk and were constantly reviewed and amended over the years as fire fighting became a municipal responsibility. The fire officers obviously had a big say in fire regulations and it appears that even though steel and iron were not combustible, they met with considerable opposition as building materials on the grounds that their behaviour was unpredictable, particularly when quenched by a hose pipe. A well-known opponent of metal structures was Captain Shaw of the London fire brigade who also achieved lasting fame for his mention in the Fairy Queen's song in Iolanthe.

In 1905, Rules for Standard Fire Resisting Construction were laid down by the Fire Officers Committee and although these regulations had no statutory force, they undoubtedly influenced many building committees.

Of course, no legislation can prevent the start of fires – this is usually a matter of human carelessness. Regulation can go a long way, however, to prevent a fire spreading and with this in mind, a group of architects set up the British Fire Prevention Committee at the turn of the century. This organisation carried out many tests on floors, partitions, doors, ceilings and other building components, and so highly regarded was their work that they soon enrolled 425 members. Their work was widely used in the formation of local by-laws and was ultimately taken over by the Department of Scientific and Industrial Research, leading to the eventual introduction of BS 476 in 1932.

All this work was highly relevant to the problems associated with the prevention of collapse of structural frames, both steel and concrete. Clearly, as a more scientific approach reduced the likelihood of the spread and intensity of fire, it would seem natural to relax the requirements. This was the basis of the argument put forward by the steel fabricating industry as rules for fire protection became unified, but they fought a distinctly up-hill battle.

Expansion Overseas

It became clear to a number of companies that the market for buildings and, particularly, for bridges was expanding in some colonial territories and that the demand would continue for many years. It was thus entirely logical to set up factories in those countries to take advantage of cheaper labour, freedom to purchase material world-wide and to enjoy the political benefit of creating technical advancement and employing local people. It was frequently found expedient to join forces with another company already established and with strong contacts in the particular country. One way or another, a handful of British companies found themselves with overseas facilities and in general they seemed to be successful. Of course, they reduced the volume of exports and some home based companies saw their overseas order books slowly deteriorating, in spite of their expertise and commercial connections painstakingly built up over many years.

To the steel makers, whose prime function was to sell steel, it mattered not where it was fabricated, which accounts for the activity of Dorman Long who, starting with office and design facilities in various parts of the world, later built fabrication

shops and finished up with the managerial problem of a score of companies with varying capabilities and products, spread across every continent.

One of the most successful companies to establish itself abroad was Braithwaite. Originally founded in West Bromwich in 1884, it had built up a fine reputation exporting bridges to many parts of the world. The company established itself in Calcutta in 1913 and in Bombay in 1921, gradually increasing its output until, in later years, it claimed two thirds of the market for steel bridges in India. However, Braithwaite was not the first company to set up in Calcutta. A & J Main of Glasgow had been there for twenty years and was among the first to introduce steel buildings. Their factory flourished, carrying out substantial contracts in India, Burma/Myanmar and Ceylon/Sri Lanka.

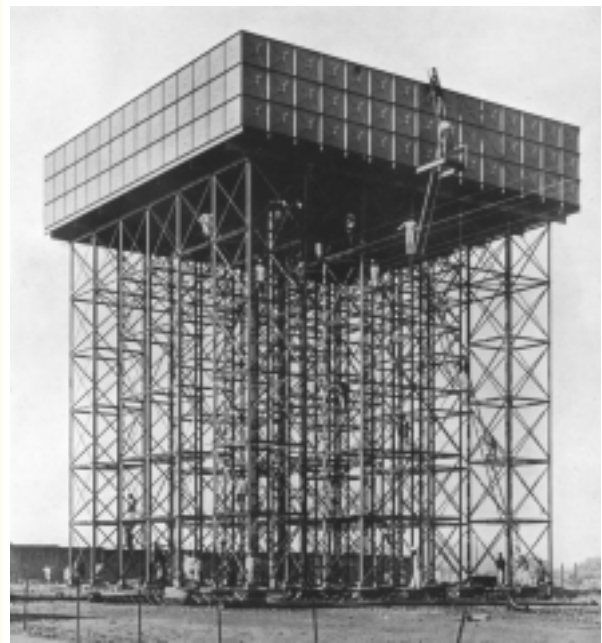

It was inevitable that both steel making and fabricating facilities would be set up in a number of developing countries. Steel bridges were the main interest as better communications were established, followed by factories but only later by offices and stores when the pressure on space in major cities made necessary much taller buildings outside the capability of traditional methods of design. British fabricators gradually lost part of an export market that they had enjoyed for many years and had to turn their attention to creating a greater demand at home.

Steel Fabrication and the Great War

Britain had not fought a continental war for a hundred years; the Crimea was remote, as was South Africa and India and the scale of what was about to happen could not be imagined. The theory that the affair could be settled quickly by a brave and well trained regular army was soon demolished but even so, the philosophy of 'business as usual' was adopted, certainly in the first year or two. Thus we find buildings like Heal's furniture store in London, with a complete steel skeleton, being built in 1916.



Men from the steel fabricating industry served in every branch of the fighting services with perhaps a proportionately greater number joining the Royal Engineers. They carried out an enormous range of duties varying from the extreme danger of constructing barbed-wire entanglements in front of the trenches to the comparative safety of working in the base camp drawing office.

First, of course, they had to provide the infrastructure for the army in France, building and maintaining roads, railways and port facilities and providing camps, hospitals, workshops, and many other buildings.

In the first few months, when the fighting was more fluid, it became obvious that the Engineers were ill equipped in heavy bridging gear and untrained in its use. This was a commodity new to the British army, but the French had, for some years, used prefabricated campaign bridges, designed by none other than Gustav Eiffel. These bridges were composed of a small number of standardised elements but were sturdy enough to support the passage of heavy artillery and were used extensively in Indochina. Later they were adopted by the Russian, Austro-Hungarian and Italian armies.

The British also lacked military intelligence on which to base their probable requirements but with tremendous speed they surveyed the bridges in northern France and ordered the necessary steel spans from the UK.

Special bridges, including pontoons, were also designed to suit a variety of purposes and loading conditions, and these were amassed in France while suitable training programmes were initiated. By the time that all this activity had taken place the war had become static and the quantities of bridging material became something of an embarrassment. It was not until August of 1918, when our troops advanced and were frequently met by

water obstacles which had first to be taken and then bridged, that the training and equipment proved its worth.

Military installations had also to be built at home, amongst which were the hangars for planes and airships. Bigger spans were an obvious necessity; steel was the obvious choice of building material. One of the airship hangars built for the Navy in 1916-17 was 280 ft span, 700 ft long and 100 ft clear height in the centre and when the war was over, it was used to build a series of airships including the ill-fated R101. It needed to be bigger and the original intention was to jack it up but it was found that, due perhaps to the lack of skilled people during the war, the quality of workmanship was anything but good. The decision was therefore taken to dismantle the building, correct any faults and rebuild it, 35 ft higher and 112 ft longer. This work was carried out by Cleveland Bridge and completed in 1926 to such good effect that the hangar at Cardington has almost become a national monument.



One result of increased armament production was the necessity to improve communications by road and rail and to build power stations to service new factories. The generating capacity in England and Wales increased from 960 Mw in 1910 to 2400 Mw in 1920, an increase which compared with today's output seems trivial, but which brought a substantial amount of work to the fabricators.

The Steel Industry

The demands of the war created serious distortions in an industry already badly managed, technically backward and not sufficiently profitable. The change from a position of over production to one of shortage brought about a very rapid expansion in steel making to satisfy the ever increasing demand for guns, shells and ships. There was no time for calm appraisal of the ultimate shape of the industry, the demand was immediate and the steel makers rose to the challenge admirably. Unfortunately, the piecemeal expansion that took place, whilst satisfying wartime needs, was anything but appropriate for a peacetime industry. Nevertheless, the profits made in the war, and what were thought to be good prospects immediately afterwards, gave the steel makers confidence to develop plans for amalgamation and expansion. In the post war boom of 1919 and 1920, share issues, in particular high yielding debentures, were used to raise money and the confidence of the industry was such that it was quite prepared by the summer of 1919, once again, to allow imports from Germany. The government had been only too happy to dismantle the wartime subsidies and the controls that had forced the industry to co-operate and so, when the post war boom very abruptly ended, the steel industry could hardly have been more vulnerable.

From an output of nine million tons in 1920, the following year saw a fall to only 3.7 million tons and the greater part of the industry was on or beyond the verge of bankruptcy for many years to come.

The post war boom helped the fabricators to readjust from shortages of labour and material to a more even balance but, surrounded as they were by an aura of optimism, few had any idea of the difficulties that lay ahead.

Thus ended a decade that had seen the old order change and, to a greater or lesser degree, no part of the world was left untouched.

Whilst some countries, without realising that the changes were irreversible, attempted to return to the values of Edwardian society, at the other end of the spectrum there was outright revolution which was usually followed by a vast increase in the production of steel since this was deemed to be a source of strength and stability. So powerful was the image of steel, stahl or stal that in 1912, a theological student turned revolutionary called Joseph Djughashvili changed his name to Joseph Stalin.



Depression Years

Depression settled on the country in 1920 at the end of the short-lived post war boom. After the high hopes and promises of a better life, people became disillusioned with the values of political and industrial action and in many areas gave support to extremists.

The Russian revolution created great excitement and groups of people from the highest intellectuals to the humblest workmen believed that it heralded a new dawn for mankind. Opposition to Communism seemed to be based not on reason or forecasts of outcome but on fear of unleashing such enormous and unpredictable forces.

Even the Labour party consistently rejected proposals that it should accept Communists into membership in spite of continuous pressure from convinced and sincere people like Harry Pollitt, a highly respected and popular leader within the Boilermakers Society. Perhaps the belief that the lives of workers should be ordered by an international body was just too much to accept in spite of its simplistic appeal.

In 1921 a huge miner's strike brought industry to a standstill, completely distorting figures for unemployment and production. It is reported that unemployment in that year was officially 11.3 per cent but was in fact probably very much higher without taking into account nearly a million workers on short time. Something like one third of the boilermakers were without work and the suffering of that trade can be gauged by the Society's expenditure exceeding its income by £600,000 in the first three years of the decade, a staggering loss and the equivalent of over thirty million pounds in today's currency.

The high level of unemployment gave power to the employers to reduce wages, a power which they unfortunately used in a heavy handed way, causing yet more strikes although, because of the erosion of union funds, these could not be sustained for very long unless the workers involved, and their families, were so determined that they would accept the most stringent hardship. In this category were the coal miners who had suffered bad conditions and poor wages for long enough. In response to the coal owners' demand for a reduction in wages and an increase in working hours, they called for support from their old allies, the railwaymen and the transport workers who responded by refusing to move the ample stocks of coal that had been built up against the possibility of a strike.

Thus came about the so-called General Strike of 1926 which was by no means general since it involved less than 20 per cent of the working population. Nor was it a strike against employers; it was a demonstration of protest against economic orthodoxy and the failure of Government to create a climate where living wages could be paid and employment maintained at a satisfactory level.

In 1925 the then chancellor, Winston Churchill, had returned the country to the gold standard, a strategy that had been adopted by other countries as well, but we were the only one to do so at pre-war parity, which artificially boosted the value of the pound and seriously damaged those companies heavily engaged in export.

Although there were a few minor economic fluctuations in these years, the general tendency was downwards and by 1930 unemployment was approaching three million.

The Steel Industry

The fall in output between 1920 and 1921, distorted though it was by the miner's strike, was a disaster for the steel makers. Financially, they suffered a double blow, since many of them had also become coal owners in order to protect their supplies. They struggled on, unable to reorganise and with insufficient finance for research and development.

Once again it was demonstrated that in an economic downturn, the demand for steel fluctuated far more widely than the general level of activity. Also in the 1920s this was compounded by loss of exports due to the high value of the pound, and the level of imports against which there was no fiscal protection.

Eventually, rationalisation became inevitable leading to the formation of a number of large groups but what was really needed was a total amalgamation of the industry, an almost inconceivable eventuality considering the parlous state of its finances. And yet, it nearly happened! A financier by the name of Clarence Hatry had, in other industries, proved that the value of the whole was greater than the value of the component parts. Following his success in amalgamating more than twenty companies, most of them family owned, into Allied Ironfounders he considered, in his own words '...that I might, with advantage to the industry and to my group, undertake the amalgamation of the leading heavy steel manufacturers...' His first target was United Steel and he came within less than half a million pounds of his goal when the Wall St crash in 1929 caused some of his financial backers to withdraw their support. Sadly, in an attempt to bridge the gap, there was some financial skulduggery, and the unfortunate Hatry was sent down for fourteen years.

The success of Allied Ironfounders should have contained a powerful message to the structural steelwork industry but it was not to be. Not then, nor at any time later, was any serious consideration given to amalgamation to avoid the worst consequences of recession and cut throat competition.

As it happened, the greatest influence on the structural industry at that time was the amalgamation in 1929 of Dorman Long and Bolckow Vaughan, which brought together the expanding fabrication activities of the former and those of Redpath Brown, one of the largest fabricators in the country, which had since 1922 been owned by Bolckow Vaughan. Both companies were virtually bankrupt and needed an overdraft of nearly five million pounds to keep them going.

Dorman Long, as a matter of policy, continued to enlarge the fabrication department, creating a captive market for its steel plates and sections. In addition to its own considerable facilities and those of Redpath Brown, in 1930, another substantial fabricator, Teesside Bridge and Engineering was taken over. The company also ventured into new products including the Dorlongco system of steel framed houses.

These activities, and the growing sale of 'simple' fabrication by other steel makers, caused problems in relationships with the fabricating industry and the uneasy truce whereby the fabricators only bought British steel and the steel makers did not quote directly to the builders was broken with increasing frequency.

Overseas branches were also opened by Dorman Long, in Cape Town in 1926 and in Germiston in 1931 supplementing that which they already owned in Durban. However, their overseas branch that was to become most important in the immediate future was that in Sydney.

Factories and Buildings

Without doubt, the industry suffered in the general downturn but by no means as severely as might be supposed. Quite a few developments were favourable for although the overall building market was considerably reduced, steel frames had become popular and took a greater share. New industries were expanding, there was a growing demand for cinemas and football stands, for bus garages, for the generation of electricity, and for oil refineries with their attendant storage facilities. Indeed, although it is not possible to produce exact figures, it is probable that the overall output of the fabricating industry was rising. It has been said before, and is worth repeating, that this was an industry with fairly low technology and a low cost of entry. Throughout its history, in spite of hard times and a number of liquidations and bankruptcies, new entrants have not been deterred and for the greater part of the last hundred years it has suffered from over capacity.

City office blocks at this time assumed mammoth proportions. Imperial Chemical Industries, for example, built their headquarters in London, a fine building completely steel framed with 6,500 tons of columns and beams. Many others followed, but they were not the only buildings to change the urban scene for this was the age of the cinema.



To simply convert theatres to cinemas was unsatisfactory, since the theatre required so much space behind the proscenium that could be more profitably used to enlarge the capacity. Large, bright new buildings with seating for as many as four thousand people were the order of the day, some using a thousand tons of steel and every one presenting problems with the delivery and erection of the balcony girder. To provide a clear span of 100 ft required a huge riveted plate girder weighing sixty or seventy tons, which had to be manoeuvred through a city centre and lifted into place using heavy derrick poles.

The motor industry in the twenties was beginning to take off. No longer was the car a rich man's toy; the Model T and the small cars made by Morris and Austin brought motoring to a much wider public, with all the necessary capital investment in new buildings for manufacture and maintenance. Road transport for both goods and people was growing rapidly and although it was still possible to find loads hauled by steam traction engines, the petrol-engined truck was rapidly growing in size and number. Local Authorities found that they had to supplement their tram sheds with large span garages to allow the flexible parking of their fleets of buses. Here was a good market for the small to medium sized fabricators since there was nothing particularly heavy in the structures. From the designer's viewpoint, there was the constant challenge of manipulating the design of lattice girders and roof trusses in the most economical way for, although the work was there, competition amongst the fabricators to fill their workshops was still severe.

On the outskirts of many towns, large steel structures began to appear in the form of football stands. By present day standards they were primitive in the extreme, consisting simply of what could have been an industrial building with one side removed and a few raked seats inside. Admittedly, the front, overlooking the playing pitch would incorporate lattice girders to reduce the number of columns to two or three in the length, but the effect was distinctly utilitarian. The stand built for Arsenal at Highbury was typical. It accommodated 17,000 people standing, a further 4,000 seated and boasted that the view was only interrupted by two 9 inch columns on the upper level and five at the lower. Of course, football had not become the business that it is today; you could watch a match for a shilling and even in the years immediately after the Second World War, a player in an international game was paid about seven pounds.

Industrially, the advance of the motor industry has been mentioned. Other areas of capital investment were chemicals along with petroleum and its by products. Here there was work for the traditional boiler making companies where some specialised in chemical plant, including pressure vessels, at that time riveted, and the associated high pressure pipework. Others specialised in storage tanks where welding was just becoming acceptable.

For the structural fabricator the work varied from buildings, storage hoppers and silos, to plant supporting steelwork and the endless pipe racks that connected everything together. Never a pretty sight, unfortunately, and not the sort of industrial development beside which anyone would choose to live.

Electrical Installations

Up to this time, the generation of electricity had developed in a fairly haphazard manner. There was a vast number of power stations, many of them with a very small output, some direct current, some alternating, but even then, with differing frequencies. It is claimed that in the early twenties, there were forty three different combinations of alternating current, direct current, voltage and frequency varying from 25Hz to 50Hz and 100V to 480V. It is hardly surprising that it was not completely unified until 1947. It was, however, vital in the national interest that there should be some regulation to make the system conform to agreed standards, so that power stations could be inter-linked to avoid total dependency on any one of them. In 1925 another Government committee, under Lord Weir, was set

up and this time the urgency of the situation began to be recognised, resulting in the Electricity Supply Act of 1926, which called into being the Central Electricity Board.

It was not until 1927 that the national grid made any progress. An eight year programme was proposed to interconnect and bring into conformity the whole of the electricity undertakings in the country, which provided a huge market for those fabricators who, with commendable foresight, had set themselves up to design, manufacture, test and erect the transmission towers that were soon marching across the country. Of course, before construction began, designs had to be established for conductors, insulators, control equipment and pylons but in spite of this delay, the whole of Britain, with the exception of the area around Newcastle on Tyne, was linked up by 1935.

It is a great pity that it is not economically possible to transmit electricity any other way for there is no doubt that the ranks of pylons are an eyesore. Even today when we tend to list anything over fifty years old, not one has a preservation order placed on it. The outrage of country lovers in the twenties and thirties can be imagined.



Bridges

Whereas the Indian State Railways had provided work for a number of companies in previous years, the ability to fabricate in the sub-continent rapidly reduced the market, making even more important, other parts of the developing world.

Since the end of the last century the Australians had been considering a crossing of Sydney Harbour by bridge or by tunnel but it took until 1920 before a scheme was finally put together, resulting in what can only be described as a design and build competition which was put out to international tender.

From this country the early contenders were Arrol and Cleveland Bridge, the latter, employing the services of Ralph Freeman as designer. Sadly, as the bid was being prepared, Cleveland's chairman, C F Dixon, died very suddenly and the remaining directors felt unable, in the uncertainty which followed, to continue. Fortunately, they, along with Ralph Freeman were able to convince Dorman Long to take over the bid. The change was approved by the New South Wales Public Works Department, which was rather surprising for although Dorman Long had a rich experience in the manufacture of heavy steelwork, they had not, at that time, completed a major bridge. Of course, they did have a branch not far from the site which may have been of some psychological help.

Tender documents were issued in 1923 and the offer from Dorman Long was not only the most comprehensive, it was also the least expensive, reflecting, perhaps, their desire to sell 50,000 tons of steel. They duly received the order in 1924 and went to work with determination. There were no short cuts or half measures in the design, in the organisation of the work, or in the methods developed for the construction of the bridge. Although practically all of the steel came from Middlesbrough, it was fabricated on site in specially built workshops with overhead cranes capable of lifting 120 tons. The 'creeper' cranes, which climbed the arch as it was built out from both sides, could also lift the 120 ton sections of the main booms. Large box sections were built up out of high-tensile plates and angles, riveted together, some sections being rolled specially for the contract, like the corner angles, of 12 ins leg length and 1.25 ins thickness. The gross area of the booms was 2693 sq ins to sustain the maximum erection stress of 18,711 tons.

While this may give some idea of the immensity of the contract, only a study of the substantial amount of literature which the bridge inspired will tell of all the technical problems that were encountered and successfully overcome. Without being in the least jingoistic, it is possible to say that this was an example of British engineering at its very best.

Meanwhile, back in Newcastle, Dorman Long completed the Tyne Bridge in 1928. Here, for an organisation new to major bridge construction, was a massive arch bridge spanning nearly 550 ft. Although of much smaller proportions, it was built on the same principles as the 1,650 ft span Sydney Harbour Bridge and its successful opening must have given a considerable boost to Australian confidence.

In the same area and in complete contrast, Dorman Long also built the Tees Newport bridge. Here, out of a total weight of 8,000 tons, the centre span, which could be lifted to allow the passage of ocean going ships, accounted for 5,400 tons with a span of 270 ft.

At home and abroad, Dorman Long seem to have made up their minds that they were to be the principal bridge builders and in the late twenties took a number of orders, which kept their workshops going for the next few years. It is, however, reported that export bridgework which was selling for £25 a ton in 1920, was going for £18 a ton by 1926 and by 1929, had dropped to £16.50, all of which suggests that more steel may have been made but that any financial benefit may well have been lost in its fabrication.

Trade Associations

Although the minutes of the meetings could hardly be described as comprehensive, they became a little more detailed and it is possible to gain some insight into the affairs of the steel fabricating industry.

It is very clear that everyone was worried about the shortage of work. Nowhere, however, is there any mention of efficiency or over-capacity. The only remedy that seemed to have had any consensus was that of protectionism.

More companies joined the associations, reducing but by no means eliminating competition from non members, but many more tender lists contained members only, which allowed an increase in the 'tender fees' that were added. This, in itself, had consequences that had not been foreseen in as much as a number of companies, colloquially known as 'fee snatchers', would do their best to insinuate themselves onto a tender list, with no intention of submitting a bona fide bid, simply in order to secure a share of the fee.

Discussions took place on matters of common interest; wages and conditions, daywork rates, problems arising from factory regulations, all were ventilated but the complaints of the members seldom resulted in a positive solution. On broader issues, members were made aware of the growing threat of reinforced concrete, of the damage done to the industry by the imposition of fire regulations and the necessity of propaganda to increase the awareness of purchasing and specifying bodies of the many advantages of using steel.

An often repeated complaint concerned the activity of the steel producers in selling simple fabrication. The problem was made worse by the agreements to fix the price of steel from the mills. Since the various steel makers could no longer compete with each other by reducing their price, a number of them offered the incentive of simple fabrication at what must have been considerably under cost. Soon they were also offering riveted compound beams and columns and while it may have appeared advantageous to fabricators to purchase from the mills, the truth was that by so doing, they reduced the amount of work in their own factories.

Also, the more widespread mills fabrication became, the greater was the temptation for them to trade directly with general contractors, architects and engineers. In fact it would have been a great deal better for everyone if the mills had never taken up simple fabrication, but this would not have overcome the problem of those steel makers, like Dorman Long and Frodingham, who had a genuine capability to engineer and fabricate contracts of any size.

The steelwork associations spent a lot of time fulminating about what appeared to them to be an injustice, but in truth, none of them refrained from purchasing cheap fabricated steel from the mills when it suited their purpose. And so the pantomime continued, with the subject cropping up quite frequently in the minutes of their meetings and negotiations continuing with the mills, in an atmosphere of dark suspicion which continued for many years, indeed it only ended when British Steel abandoned fabrication in the 1980s.

The steel makers had introduced a rebate scheme for fabricators in an attempt to ward off foreign penetration of their market and the fabricators saw this as an opportunity to strengthen their associations. If they could persuade the steel makers only to

allow rebate to members, then the rest of the fabricating industry would be forced to join and with everybody on board they would be able to create a watertight protectionist structure and sail happily through the economic ice floes. Discussions between the two parties made little progress and the twenties ended without agreements.

It may seem that the various associations of fabricators were inward looking and could offer nothing better than devising schemes to protect themselves from fair competition. It is, however, reasonable to ask, what else could they do? They were abused by purchasers while their own desire to survive and to keep their labour force intact was driving prices down to a level which could well have destroyed the greater part of the industry. Steel makers had been encouraged to fix prices to prevent their industry, which was of vital national importance, from complete collapse, why should the same philosophy not be extended to the fabricators?

Tentative moves towards promoting steel construction were made by the propaganda committees of the regional groups without significant progress until, in 1928, The British Steelwork Association was established, supported by both fabricators and steel makers, with the declared intention of promoting the use of steel for constructional purposes, by means of publicity, marketing, information and technical research.

Considerable impetus was given when, on the initiative of the new Association and with its financial assistance, the Steel Structures Research Committee was created and had the very good fortune to be under the technical direction of one of the most influential structural engineers of the time, J F Baker who in 1977, as Lord Baker of Windrush, was created a life peer. For the first time, the fabricators had emerged from their parochial deliberations and supported the foundation of an organisation of national significance, whose response was rapid and far reaching.

The Fabricating Industry

In the turmoil of this decade, with a world depression, it must be obvious that the whole industry was fighting for survival. It is, nevertheless, a matter of some surprise to discover that the failure rate was nothing like as high as might be supposed, nor was it any where near that which occurred in periods much later in its history.

For this, there are a number of reasons, but first, the financial structure of the industry must be touched upon. Since it was factory based, there was an inescapable fixed overhead, which became all-important since companies operated on slender profit margins. It was also traditional that the industry took an optimistic view and calculated the overhead on the basis that the factory would be kept working at or near full capacity. To achieve this has been, over the years, a continuing obsession in the industry and the thoughtless price cutting, simply to maintain full production, has led to the downfall of many.

There were, however, alleviating features. Labour in all categories could be hired and fired at a few hours notice and it was only necessary to retain those few key personnel whose loss would have spelt ultimate disaster. It was unlikely that others would be able to find alternative employment and were thus available as soon as there was any upturn in the workload. This is, of course, an over simplification since employers were nowhere near as brutal as it might suggest. Many companies

were privately owned, and the owners fought hard to keep a loyal labour force in employment, usually at considerable cost to themselves.

Private ownership also meant that companies tended to be cautiously financed. Investment had been made out of profit which may seem a contradiction when it is also said that profits were low, but it must be remembered that the cost of buildings and equipment was also low. Unlike some later periods, therefore, bank borrowing was minimal, which, again, gave companies greater flexibility.

In the last two years of the decade, there was a slight improvement in the amount of work available, giving hope to an industry which had suffered nearly ten years of depression. Sadly, any optimism was misplaced for the worst was yet to come.

The Institution of Structural Engineers and The Institution of Civil Engineers

It may seem odd that these bodies have so far not been mentioned. Both had been in existence for many years, the Civil Engineers since their foundation at the beginning of the nineteenth century and the Structural Engineers since 1908 when they were formed under their original title of the Concrete Institute. With a name like that, it is hardly surprising that they were viewed with a little suspicion by those concerned predominantly with steel structures who were not sure to which Institution they should offer their allegiance. The name was changed in 1922, from which time the Institution has drawn together structural engineers from the many facets of the profession in country-wide branches in the British Isles and in many other parts of the world which were former colonial possessions.

Both Institutions have grown in scope and authority over the years, in theory, in practice and in educational standards. But just like trade associations, they are only as good as their members and the quality of those leaders that the members have chosen.

By the end of the twenties the world was in a state of economic upheaval from which Great Britain was certainly not excluded. By far the most serious evil was continuing unemployment with no sign of relief. As is usual in depression, the heavy industries suffered most and those areas where people relied on steel and coal for their livelihood were by far the hardest hit. It is a constant source of surprise that protest in these troubled times, in spite of severe provocation, was generally good natured and frustration seldom led to violence – a remarkable tribute to the humour and common sense of the people in that era.

Trades Unions

Large scale unemployment disfigured the face of Britain in the decade before the Second World War. There were diametrically opposed and passionately held views as to what could be done about it. There were those who still supported our adhesion to the gold standard while others, including members of the TUC, adopted the theories of J M Keynes. What was abundantly clear was that government, of whatever persuasion, had, after two hundred years of industrialisation, still been unable to find any solution to its attendant economic problems.

The policy of drastic cuts in public expenditure was attempted by the National Government of 1931. It was proposed to reduce unemployment benefit and cut the earnings of all state employees, including teachers, the police and the armed services. There were dramatic repercussions, amongst which the Invergordon mutiny probably had the greatest impact on the ruling circles and caused them to modify their plans. Although there was a promise that there would be no victimisation, the leaders of the mutiny were dismissed from the service and in later years some emerged as trade union leaders, one or two in the construction industry.

Membership of trades unions increased sharply, not in the traditional heavy industries so much as in 'new' industries and often in parts of the country with no tradition of organised labour. There were serious demarcation disputes between different unions which led, for example, in the motor industry, to fragmentation of membership instead of having a single bargaining agency. There were many strikes for union recognition, frequently led by militant shop stewards without the authority of the unions, which had been slow to react to the developing industries.

The Boilermakers Society, at this time, found itself in dispute with the Constructional Engineering Union over the organisation of steel fabrication workshops. Although the society had its origins inland, it had become predominantly a ship building union, so much so that boilermakers in other industries were regarded as lesser mortals and some branches refused to accept into membership men from fabricating shops. Throughout the thirties the society, which was losing members in the seriously depressed shipyards, adopted a policy of recruitment amongst the fabricators, pointing out that the CEU did not restrict its members to craftsmen and was therefore less able to represent skilled men. By the end of the decade, their success was almost complete, though one or two shops still adhered to the CEU.

The Fabricators and the Steel Industries

The activities of both making and fabricating steel became so intertwined and the agreements between the two depressed industries so convoluted that it is difficult to comment upon them separately.

Across the nation, lack of finance brought about a standstill in capital investment with disastrous effect on the heavier end of manufacturing industry and on the building industry, though not to quite the same degree. The steel makers were, almost in their entirety, in the hands of the banks, but the politicians knew only too well that it was a national imperative that they should be sustained. The effect of harsh competition had not brought

about the desired reforms and eventually it became necessary to protect them from foreign competition by imposing a temporary import levy of something like thirty per cent. This seems to have been done with some reluctance and was based on the requirement that the industry should "...show some determination to set its house in order".

For a long time prior to this development, the fabricators had been negotiating with the steel industry in an effort to end the strife caused by their, so called, 'simple fabrication' activities. Eventually a demand was made that there should be minimum prices for various categories of work below which the steel makers would not quote, to which the steel makers replied that the demand was unreasonable, since once their minimum prices were known, the whole fabricating industry would be able to undercut them, indeed, the demand was only worth discussing if the fabricators were, in turn, prepared to accept the same conditions. In this way, the minimum price agreement came into being and many pages could be filled with the details of negotiations and of the complexities of its workings. It had taken some years to reach this position but finally, in January 1935, the details were in place, with the result that almost immediately the fabricators found their prices hardening but it is not surprising that there were continuing disagreements, most of them between the fabricators themselves. The industry consisted of a large number of companies of varying sizes with a considerable diversity in the type of work that they undertook. At one end of the spectrum were the companies whose size would enable them to build a 50,000 ton bridge while at the other were manufacturers of the smallest agricultural buildings. Furthermore, no two structures were the same, each being individually detailed. In these circumstances it can be seen that any common price structure would have to be impossibly complex or, alternatively, those involved would have to accept pluses and minuses which eventually balanced out, leaving them with a reasonable profit. Rather like pieceworkers, however, the fabricators complained bitterly about the unprofitable rates but kept very quiet about the others.

It may well be asked why the steel makers maintained these agreements after their own position had been strengthened by government intervention but it seems that the two industries were considered together and both were deemed to be in need of support to the extent of government blessing on the minimum price agreement. However, any price fixing arrangement arouses suspicion and it was not long before questions in Parliament provoked an audit of the scheme. The investigation was inconclusive since it found, not surprisingly, a wide variation in costs and selling prices. Although no comment is made on the subject, it is highly questionable whether many fabricators had adequate costing systems in place, a managerial failure that had contributed to their wild price-cutting. In the end, responsibility was placed on the British Iron and Steel Federation, to which the newly-formed BCSA had become affiliated, to equip itself with sufficient data to enable it to answer any complaints that arose.

By the time that all these protectionist arrangements were in place, the amount of work available was on the increase, workshop capacity began to fill and it was not long before whispers of steel shortages began to be heard.

Technical Developments

The Steel Structures Research Committee's first report in 1931 recommended that a code of practice should be established for the use of structural steel in buildings and, with commendable speed, BS 449 was put together. Now, at long last, the designer had a nationally accepted set of rules and he knew, when he submitted his calculations to the local authority, that there was no reason for their rejection.

It is interesting here, to observe that one recommendation, that permissible stress should be raised from 7.5 tons to 8 tons per square inch, brought the figure back to that which was originally suggested in 1874 by the British Association and confirmed by a committee appointed by the Board of Trade. This latter body, in its infinite wisdom, had immediately reduced the figure to 6.5, leaving British practice far behind that of the Continent where stresses up to 10 tons per square inch were not uncommon.

The final report of the Research Committee in 1936 showed that the behaviour of a building structure is far too complex to allow a simple design method. Apart from the frame itself, account should be taken of floors and walls in addition to the stiffness of concrete encasement. New rules were suggested which, though rational, were not adopted because the methods were considered to be far too complicated.

Although methods of analysis of rigid frames were available, following in particular the introduction of the Moment Distribution method by the American Professor Hardy Cross in 1932, they were not in general use, except for the simplest frames, until the development of computers thirty years later.

The 1932 code of practice governed steel design until the outbreak of war when it was decided, largely on the evidence of research into the behaviour of beams and portals in the plastic range that for the duration of the emergency the working stress in bending should be increased to 10 tons per square inch, a figure which was maintained after the war and incorporated in new codes.

The materials used in steel structures changed very little. The range of sections was subject to minor adjustment from time to time, mild steel predominated and connections were made both in the shop and on site by rivets. There was occasional use of high tensile steel in both buildings and bridges and on site there was an increasing use of 'black' bolts, in other words, bolts which had been forged and not machined. This came about after a report, made by the Institution of Structural Engineers in 1927, included allowable stresses for this type of bolt which had become more refined and reliable. Their use was permitted in the 1930 act but there was still a reluctance to accept them in spite of their very obvious economy and only a shortage of site riveters led to their eventual, almost complete, acceptance. Even then, in special situations, either rivets or turned and fitted bolts continued to be used until high strength friction grip bolts came on the scene twenty years later.

In the workshops there had been little change since the beginning of the century. Processes were a little faster but equipment was, in principle, just the same. Perhaps the only introduction in thirty years had been pneumatic tools, particularly the riveting hammers which permanently deafened so many of the men who had to work with them. Developed in the late twenties and early thirties, the ability to cut steel using oxy-acetylene was a significant move forward and, being a process with very low initial cost, it quickly became universal.

Some men developed extraordinary skill with 'burning' equipment and could cut sections, make remarkably accurate holes and even, by judiciously heating and cooling, camber a beam to a close tolerance. It was always said that you could set up as a fabricator with a garage and a burning set. Not quite true, for you needed one other piece of equipment which, starting in the late twenties, has over the years changed many aspects of both design and fabrication – the electric welding set.

Welding

With the caution that we have grown accustomed to expect, the advent of welding was treated with some suspicion and made slow progress in design, in detail and in workshop practice. The caution was justified because such research as had been done on the subject was not widely disseminated, leaving people with concern about the metallurgy of welds, their deterioration over time and the risk of cracking under working conditions, particularly where reversal of stress was involved. Training of operatives was also inadequate. The apprentice system could not be expected to work, since there were no skilled tradesmen already established, and although some companies organised training schemes, many operators were simply left to pick up the skill as they went along. However, by 1934, it was deemed that welding was sufficiently developed for the LCC Building Code to permit its use in structures. But clients were suspicious, engineers were unhappy at risking their reputations, and each design had to be scrutinised by local authorities who often demanded considerable revision. In any case, the economies that could be demonstrated were not very great.

Long after the event, many companies and many engineers claim to have been responsible for the 'first' welded structure or bridge but not one of them took a significant risk since early examples were all on a small scale. As early as 1931, a small gantry was built for the LNER in Darlington. It only contained 79 tons of steel and it is reasonable to assume that it was an experiment with a new form of construction.

One of the leaders in the adoption of welding was Felix Samuely who designed the well known Bexhill Pavilion, not a job of great size but the overall effect was greatly admired. He was also responsible for the design of welded Vierendeel girders for the façade of Simpsons in Piccadilly but this time he was just too far ahead, for the LCC turned the scheme down and plate girders had to be substituted. Here was a frequently-quoted example of the client, Alex Simpson, encouraging the best of contemporary design. However, it must be observed that whilst the architect and interior designer receive honourable mention, the structural engineer did not – despite that fact that his skill made the famous façade possible. It is sad to learn that the world famous store has now closed and it can only be hoped that the integrity of its grade II listed building status will be maintained.

Conscious of their responsibility to the travelling public, the railway companies took plenty of time to consider the merits or otherwise of welded steelwork, and it was not until 1938 that we hear of a welded bridge being constructed at Ladbroke Grove

From the middle of the decade, welding advanced slowly but steadily and most fabricators had developed some competence by the time that war broke out in 1939.

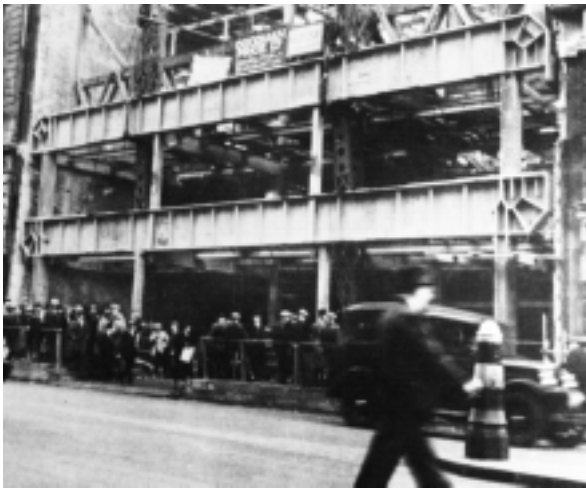

Trade Associations

The British Steelwork Association was partially funded by the various local societies and the fabricators were delighted to be able to claim some credit for the excellent work that had been done. Their self esteem, however, turned to howls of dismay when it was proposed that the BSA should act as the co-ordinating body for the various local trade associations. The Steelwork Society, based in Manchester, had a healthy distrust of any organisation south of Crewe, and held that this new body, based in London, could have no concept of conditions in the north. In 1931, a conference of the fabricating trade associations, along with the Bridge and Constructional Ironwork Association, approved by a narrow majority, a resolution appointing the BSA as managers of their federation. The Manchester men were almost unanimous in their opposition, but were eventually led into the fold.

The BSA, now representing, and largely dominated by, the fabricators, guided negotiations with the steel makers in an effort to secure preferential treatment for members. This, the steel makers accepted but only on the understanding that the local trade associations admitted anyone with fabricating ability. This led to a dramatic increase in membership, from 92 at the beginning of 1935 to 159 in April 1936. The local associations still retained some autonomy and operated to differing regulations, which led to disagreement between them from time to time. The Bridge Builders were somewhat aloof and the Tank and Industrial Plant Association seemed to hover on the fringes. It was clearly necessary that the common interests of all these groups should be adequately represented, that there should be some standardisation in the way that they operated and that they should be embraced by one organisation which could be affiliated to the British Iron and Steel Federation.

In effect, this meant an enlargement of the activities and authority of the BSA and the new organisation entitled The British Constructional Steelwork Association came into being on April 1 1936.

It was almost inevitable that in bringing together such a diversified industry difficulties would continue to arise, particularly over the workings of the minimum price agreement. As might be expected, many fabricators studied the fine print and either found, or imagined they had found, a number of loopholes which they were glad to exploit to their advantage. The minutes of association meetings are littered with references

to sharp practice and cries of 'foul'. In fact, many fabricators were found guilty of infringing the rules from time to time but the advantage they gained usually far outweighed the penalty that was imposed.

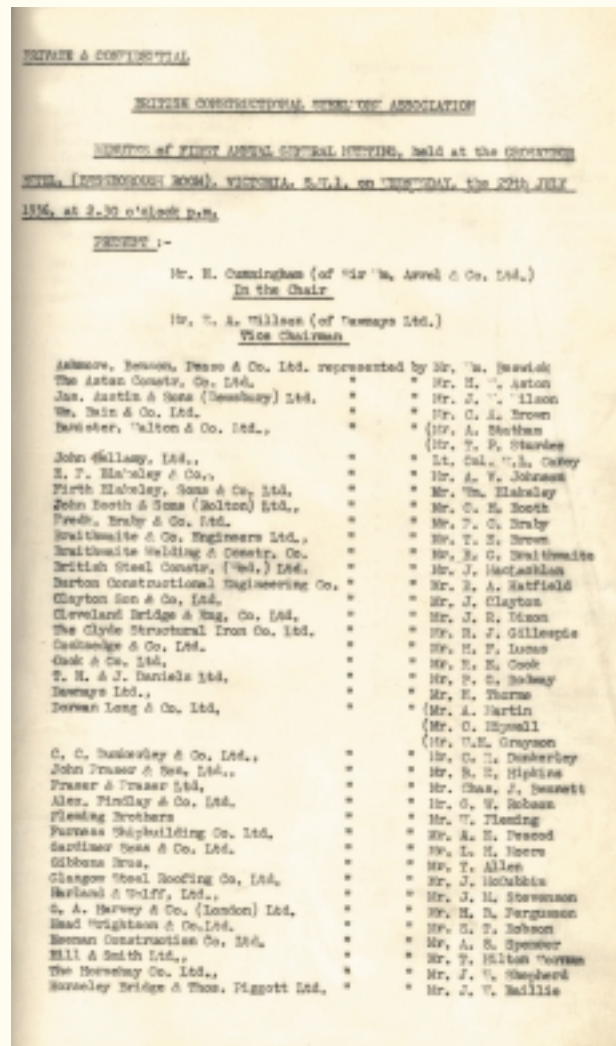

One serious objection to the minimum price scheme came from the smaller companies, who argued with some logic, that if everyone quoted the minimum price, there would be a tendency amongst the customers to place their work with well established companies of good repute. They therefore proposed that there should be some form of allocation, so that they were never left out in the cold. The imagination boggles at the idea of such a scheme being superimposed on to agreements that were already proving difficult to sustain. Although the fabricators and the steel makers entered into discussion, it seems probable that they dragged their feet and hoped that the problem would go away which, indeed it did, for all such matters were swept aside by the outbreak of war in 1939.

Although its life was short, the excellent work done by the BSA should never be overlooked. Its initiative in research brought real economies to the design of structures while, at the same time, its promotional efforts, which included some excellent literature, were widely applauded. In these respects, the high standards set an excellent example for the BCSA to follow.

Industrial Buildings

In one of its publications, directed towards persuading people into the better design of factories, the BSA remarked "It is not long since the factory was assumed to be entirely outside the province of the architect". Now, however, a new interest in design was shown by some of the "high technology" industries of the day. While the process buildings were, more often than not, steel framed, the façade commonly consisted of offices built in reinforced concrete. Good examples can be seen on arterial roads in many cities, some of the best having achieved listed status. The architects showed a new interest, but, of course, were still inhibited by commercial considerations and frequently were only called upon to do a tidying-up job on that which the engineers had created. Unfortunately, the public and to some extent the architects themselves considered that their brief was concerned only with the outside of a factory. Accepting that in many cases not a great deal could be done, this was certainly not the case internally where the employment of good design could have made a significant improvement in working conditions. As long ago as 1911, Walter Gropius wrote ... "Palaces of work must be built which give the factory worker – the slave of modern industrial production – not only light, air and cleanliness but also a sense of dignity".



One of the biggest developments of the time was the Ford Motor Company's factory at Dagenham, the first completely integrated motor manufacturing plant in the country. Ford had previously occupied a factory at Trafford Park in Manchester and the same team of architect, Charles Heathcote and Sons, and steelwork contractor, Redpath Brown, were again employed. The new factory set standards of efficiency that surpassed anything else in this country, enabling Ford to make its smallest car with a selling price of just £100.

Power stations of un-thought of size made good design imperative. Even though the national grid was well under way, power was still generated as close as possible to the user, and since there was a requirement for cooling water, facilities often had a riverside setting. Battersea, opened in 1934, eventually used twenty thousand tons of structural steel. This can be compared with the fifteen hundred tons in the first Ferrybridge station, considered to be pretty big when it was built in the mid twenties. Sir Giles Gilbert Scott was appointed to design Battersea, setting a necessarily high standard for such a huge mass of building, highly visible in the capital city. Architects employed by local authorities also played their part in improving the standard of what may be called public industrial buildings,

workshops, garages, wholesale markets, even abattoirs where that which was built by Liverpool Corporation absorbed 3,700 tons of structural steel.

Although the re-armament programme was slow to get under way, the middle years of the decade saw the beginnings of factory building and factory conversion for all the many and various requirements of the armed forces. Facilities for the construction of aircraft and their storage hangars, both provided work for the fabricators, as did ordnance factories dispersed in some isolated parts of the country.

Urban Buildings

The bigger developments, both public and private, were predominantly steel framed in these years. Building of huge offices, started in the previous decade, continued apace. Two of the biggest, Shell and Unilever, both on the north side of the Thames, each contained eight thousand tons of structural steel frame and both were erected in less than five months, amply demonstrating one of the huge benefits of this method of construction. At the same time, on the other side of the Atlantic, the Empire State building, with fifty thousand tons in its frame was erected in six months, setting a standard for the world to follow.

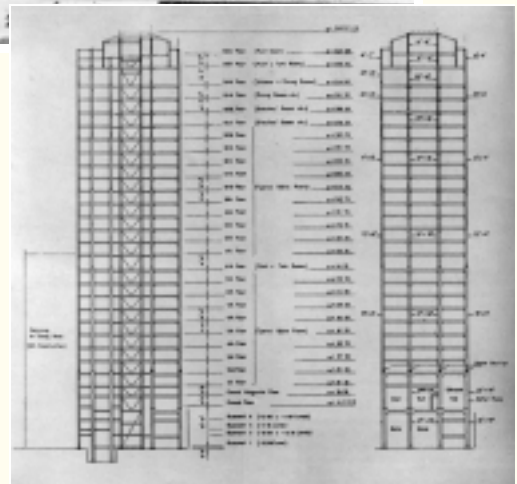

In buildings not quite so large, steel was also chosen for the frame and perhaps one of the notable signs of approval in the middle of the decade was its choice for the new RIBA headquarters. This was a traditional riveted frame but instead of being restricted by cross walls, the occupants enjoyed the freedom of open spaces created by long span plate girders. Municipalities, too, took to the steel frame for their new buildings. Lewisham Town Hall and the Manchester reference library were just two of a type of building where the frame was more complex than the stanchions and beams found in city office blocks.

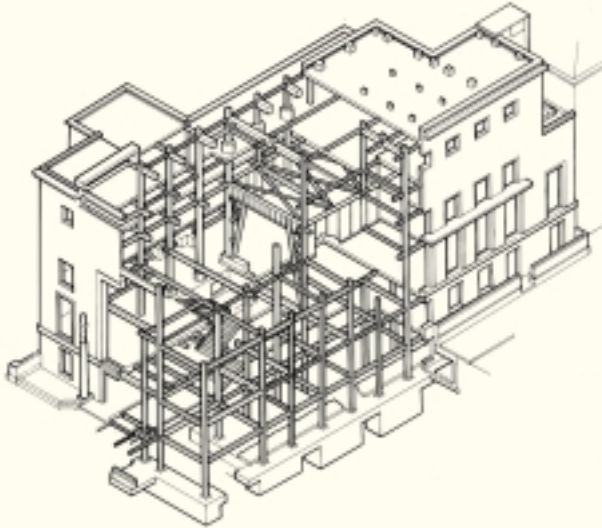

Hospitals, universities and blocks of flats all followed the fashion but while this seemingly firmly established method of constructing building frames offered the fabricators a rosy picture of the future, they paid insufficient attention to the threat of reinforced concrete, highly regarded on the continent and making slow but steady progress in this country. Ten years later, concrete was given an artificial prominence and many more years were to pass before the steel frame recovered its share of the market.

Bridge Building

The severe public spending restrictions almost eliminated work on the infrastructure, leading to the deferment of many projects leaving the country with a road system that has never caught up with the advance in the number of users. Few steel bridges in the United Kingdom were built in the thirties; one of some significance however, crossed the Thames at Lambeth and between the caissons and the arches, incorporated nearly five thousand tons of steel.

But there was some compensation in the number built overseas, many of considerable size and interest. India was no longer a major customer since so much could by this time be fabricated locally but markets were found further east as well as in many countries in the African continent. Bridges containing large tonnages of steel were constructed by Dorman Long in Thailand and in China where, sadly, the men who built the Chien Tang River Bridge saw their work destroyed, just as it was completed, by Chinese troops retreating before the advancing Japanese.

South-east Africa saw a number of interesting river crossings of some distinction. The largest, in terms of length and the weight of steel involved was the Lower Zambesi Bridge, built by Cleveland. This was of such proportions as to require a resident European staff for some years and to make their life tolerable on the harsh and isolated site they were provided with tennis courts, a squash court, billiard room and a nine-hole golf course. Nor was their health neglected, for anti-malarial measures included the draining of standing water over a wide area and regular aerial spraying. In the finished structure of 12,064 ft, the main components were thirty-three latticed spans of 262 ft 6 ins. Altogether a formidable job and one that the manufacturers acknowledged tided them through the worst of the depression.

Quite different were two Dorman Long bridges. An arch of high tensile steel cantilevered out from each side of the Sabi River to form the Birchenough Bridge with a clear span of eleven hundred feet. One of the longest arches in the world at that time, it is also considered to be one of the most graceful. The other was the Otto Beit suspension bridge over the Zambesi, an uncommon form of construction for a British contractor, which spanned twelve hundred feet. The cables were built up out of parallel wires instead of pre-formed spiral wire ropes but the system was not as sophisticated as that invented by Roebling and used by the Americans in the 1930s to build the very much bigger George Washington and Golden Gate bridges.

The expertise of British bridge builders and consulting engineers was called upon in many other countries, the Sudan, Egypt, West Africa and also in India for local fabrication had not reduced the dependence on proven design capability. Nearer home, in Denmark, the whole design for the Storstrom Bridge was prepared by Dorman Long. Carrying road and rail between the islands of Zeeland and Falstar the bridge was completed in 1937 and had an overall length of 3,211 m including the approach spans.

There can be no doubt that by far the greatest achievement in this era was the completion of the Sydney Harbour Bridge which must surely be one of the most famous structures in the world. Of course, it benefits from a dramatic position, and in spite of supporting, as it does, the tremendous weight of a deck one hundred and sixty feet wide, carrying rail track and roadways, it is still remarkably graceful. Not quite the biggest arch span in the world, but at sixteen hundred and seventy feet, it came, at the time of its opening, within five feet of so being. Bridge building is a very serious business but it does occasionally have its lighter moments. The opening of the Sydney Harbour Bridge produced its own episode of pantomime which, instead of being laughed off, was taken as an affront to the dignity of the government of New South Wales.

Jack Lang led a ruling party which was far to the left and resisted the demands of the New Guards, an organisation equally far to the right, that the opening should be conducted by a member of the Royal Family. Instead, he decided that the ceremony should be a local affair but included the pomp of a mounted guard of honour and the playing of the national anthem through which the members of his party are said to have remained seated with their hats firmly in place. Unbeknown to the authorities, a member of the New Guard, one Captain de Groot, fully uniformed and mounted, had insinuated himself into the rear rank of the cavalry and, as the official party moved forward, he spurred his horse, drew his sword and neatly cut the ribbon, crying "On behalf of the decent and loyal citizens of

New South Wales I now declare this bridge open". De Groot was later charged with "Having maliciously damaged a ribbon, the property of the New South Wales Government to the extent of £2." A knot was tied in the ribbon and the ceremony proceeded. While attention was diverted, one of Dorman Long's people quietly cut the ribbon on the other side of the knot and kept it as a souvenir. Apart from the glory of building such a fine bridge, the knot was the only satisfaction that the company achieved, since part way through the contract the Australians devalued their currency by 21% which, on top of the very keen price that had been quoted, brought about a loss said to be of the order of one million pounds.

Exports

Since records are more available, it is much easier to speak of the bridges that were built overseas than all the other varied work that was carried out by the steel fabricating industry.

Although local facilities had been established in India and South Africa which almost eliminated the market for imported structures, even these occasionally had to be supplemented and opportunities still existed for more specialised products such as plant structures for mines and quarries. At the same time, companies had to seek contracts further afield. A great deal of work was still railway-related. Workshops, engine sheds and stations still had to be built and where new ports and harbours were opened, warehouses were constructed in steel, as were most of the factory buildings that sprang up around them.



Water supply, irrigation and hydro-electric schemes required not only buildings but also pipelines and penstocks, all of which provided work in the home country and was obviously of more interest to those companies who had specialised in platework. These companies found an even greater market in the oil industry where rapid development called for storage tanks in every port and in every country in the world as well as pipelines crossing hundreds of miles of desert.

It is extraordinary that in the 1930s, a time of severe economic depression, so much was achieved in the quality and in the quantity of building both at home and overseas. In spite of the shortage of work and the cut prices that the fabricators complained of, it is very surprising that so few of them ceased trading, indeed, if we assume that each was striving for greater efficiency which inevitably leads to greater output, it would seem probable that capacity continued to increase. It was fortunate that in 1939 the nation found the fabricating industry in good shape for its skills, determination and adaptability were about to be tested in five and a half years of total war.

CHAPTER 7 – 1939 TO 1945

War

The history of the Second World War is well recorded – too well, some might say, for after nearly sixty years it is still the subject of books and films few of which bring any realism to the horrors of conflict any more than they are able to represent the true spirit of the times. As Winston Churchill forecast in 1940, success against all the odds now enables the British people to claim, with justification, that this was their finest hour. Indeed, for a nation in continuous decline since the beginning of the century the heroism, sacrifice and ultimate victory are amongst the few things that we can look back upon with pride.

The declaration of war in September 1939 was followed by some months of what the Americans dubbed ‘the Phoney War’ which provided an unprepared nation with some time to gather itself and to put into place the necessary orders and restrictions. Most industrial organisations had lost a great number of employees to the forces, making the understanding and implementation of a string of government regulations extremely difficult.

Those civilians who lived in the cities that came under attack had the nerve-racking experience of continuous nightly bombardment but they were an unfortunate minority. For the majority of the population there was full employment, very little poverty and a well organised and administered system of rationing which spread the burden of shortages across the entire nation. There was, of course, a black market but the patriotism of law-abiding citizens and a determination to share the sacrifices that had to be made kept its operation to a very small scale.

The war thus produced its own egalitarianism fuelled by propaganda continuously emphasising freedom and democracy, which became a significant factor in swinging our politics to the left. Perhaps the greatest political impact was made by our alliance with the Soviet Union. After the revolution in 1919, the general animosity towards the Russians persisted and was intensified by their treaty with Nazi Germany in 1939. However, their eventual participation in the war and their fantastic bravery and sacrifice led to tremendous admiration and a softening in attitude towards socialism.

The general election of 1945, held just as soon as possible after the end of the war in Europe, produced a huge swing to the left and set a new scene for management, employment and investment in industry.

Trades Unions and Labour

The TUC gave its full support to the government once war had been declared. To alleviate skill shortages, lines of demarcation were relaxed, women were allowed to train for skilled jobs when men were not available and many hard-won agreements were abandoned. Realising the vital importance of their support, the government issued instructions to both civil service and employers that they must co-operate fully with trades unions and, in 1942, passed the Restoration of Pre-war Practices Act, guaranteeing a post-war return to any agreement that had been adjusted to increase production. Another ‘morale booster’ was the publication of the Beveridge report in 1942, setting out the framework for a future state welfare scheme.



In the process of persuading the very best efforts out of the armed forces and the working population a general belief was created that after victory had been achieved, we would never return to the miseries and injustices of previous decades. ‘The Workers’ achieved an entirely new status; their efforts in sustaining the war machine by toiling for long hours in frequently difficult conditions, and paying a high rate of taxation as well, should not be forgotten, nor should the efforts of senior trades unionists who having, in the thirties, reversed the pacifist stance that had been in evidence before the First World War, made prodigious efforts to organise labour to the greatest level of efficiency. Naturally, there was some weakening of trades union control at local level and as in 1914-18 there was an upsurge in unofficial bodies of shop-stewards, tolerated and perhaps not particularly detrimental at the time but unfortunately leading in some industries to near anarchy in the post war period.

The TUC, who had always believed strongly that the only solution to the problems in major industries, particularly coal mining, steel making, transport and ship building, was public ownership, took advantage of the political climate to press their case and convinced the Labour party that this should be part of their manifesto for post-war reconstruction.

The Steel Industry

After the catastrophic trading conditions of the twenties and early thirties, which brought most of the industry into the hands of the banks, conditions started to improve as rearmament increased demand. Some companies were actually paying dividends by 1936 and by 1938 steel was booming partly because the economy, too, was enjoying a modest upturn. By the time of the Munich crisis in 1938 many steelmakers had substantial developments under way, a process which continued throughout the war, for these were prosperous years. This new turn in the fortunes of the industry was brought about largely by the price fixing agreements of previous years, conditioned as it was by an expectation that capacity would never be fully utilised. Of course, in wartime every plant was driven to produce the maximum possible; indeed, some old plant that had been shut down was put back into use. High profits were made in spite of the severe problems that had to be overcome.

An industry that had always been short of middle management found itself in great difficulties as men joined the forces while at the same time government legislation became increasingly complex. Shortages of labour, and of most commodities developed, requiring great ingenuity to maintain production but one of the most difficult problems was the necessity, in some plants, to change from imported iron ore to that which was home produced, very often of different quality and characteristics. This change also had a serious impact on the railway system since huge tonnages had to be transported around the country.

It is remarkable that, in spite of all the problems that had to be overcome, the industry was still able to find sufficient resources to plan ahead for post war development. The more enlightened realised that the success of iron and steel-making under the temporary controls imposed by government clearly indicated that some form of overall co-ordination was needed. Studies were available demonstrating the huge benefits of scale in American production where the labour content in the fundamental process of iron making was half that of the UK. But there were still doubters – those, perhaps, with memories of the collapse of the very short boom at the end of the First World War and also those who might have accepted rationalisation but would never agree to nationalisation.

The performance of the iron and steel industry in a period of great national danger was superb. Old plant was coaxed into use and kept operational for far longer than could be expected; at the same time new plant was installed and production increased. This could never have happened without the patriotism and diligence of everyone concerned, nor indeed without paying off the banks and accumulating substantial financial resources.

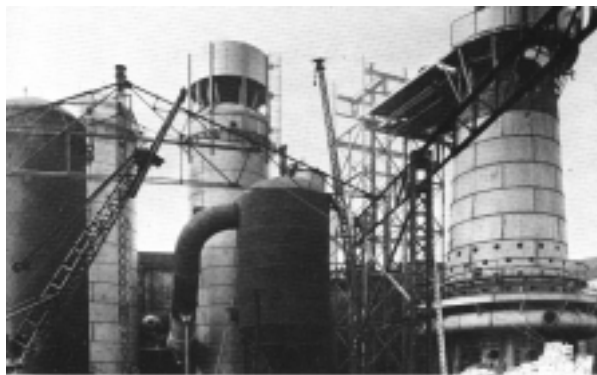

The Fabricating Industry

In many respects the problems that had to be faced were similar to those of the steel makers and, indeed, of any other industry involved almost entirely in work related to the war effort. Uncertainty of material supplies, shortage of labour, complicated regulations and ever-increasing demands were overcome with the same determination.

One of the most immediate tasks undertaken by the fabricators was the 'blacking out' of iron and steel making. The light given off when furnaces were tapped, when a Bessemer converter was blown, or in any other situation where molten metal was poured, was dramatic, all the more so when surrounding areas were in complete darkness. The rudimentary shelter, which was all that existed in many cases, had rapidly to be enclosed

without disrupting production, requiring great ingenuity by the design engineers and particularly by those who had to devise the methods and carry out construction of steelwork and sheeting on site. What is very surprising is that there were nowhere near as many air attacks on this type of plant as its vulnerability might suggest and perhaps the effort expended in the bombardment of cities, by both sides, might have been redirected to greater strategic effect.

Virtually the whole of the steel fabricator's output was directed to essential work. Large tonnages were incorporated in new facilities for the iron and steel industries as well as in the maintenance and more efficient re-arrangement of plant. Consumption of electricity continued to rise, requiring additional generating capacity. The railways had to be maintained, as had all other modes of transport and the roads and bridges that supported them. Factory building continued in all shapes and sizes, for essential work was carried out in small units as well as in the monster establishments built in some remote parts of the country and referred to as 'shadow factories'. Another enormous requirement was for aircraft hangars of which three or four standard types were developed and put out to tender by the Air Ministry. Many of these structures can still be seen on disused airfields some of them well maintained and in excellent condition. In addition, there were constant calls for steelwork to carry out emergency repairs to bomb-damaged buildings and services, often answered with astonishing speed.

All this was traditional work with which the fabricators were completely familiar but other requirements of a very different nature began to appear. At the lighter end of fabrication came the 'Table Top' air raid shelters, designed, it is said, by Prof J F Baker using his plastic method. Many thousands were installed literally inside houses, providing a strong point around which the building could collapse without damaging those who were sleeping inside. There were, it must be said, those who preferred the rigours of the corrugated iron Anderson shelter in the back garden rather than run the risk of entombment.

Unlike previous military bridges, where the workmanship had been fairly simple, the newly developed Bailey Bridge had complicated, all welded components, made to exacting standards so that all were interchangeable. Parts were made in many workshops, encouraging the development of welding and the training of many operatives in this new skill, amongst them groups of females, accepted for the first time by the Boilermakers Society. The Bailey Bridge with its great adaptability was a tremendous success and was put into use in every theatre of war. It was used not just for conventional road bridges, but also for towers, piers and suspension bridges and, what is more, it is still being manufactured and exported more than fifty years later.

Most fabricators at that time maintained a fairly broad output and could turn their hand to platework as well as structures. Obvious examples are bunkers and storage vessels where welding was beginning to take over from bolting and riveting. It was a short step for these skills to be employed in the assembly line manufacture of bodies for armoured cars and tanks. In a similar way, some fabricators found themselves making landing craft and later in the war, when so many merchantmen had been sunk, sections of ships which were then sent to the yards for incorporation into hurriedly built replacements.

Unlike the steel makers, the fabricators made little new investment during these years. Apart from the growing introduction of welding, there were few innovations either in method or equipment.

The Invasion of Europe

After months of rumour and speculation, British and American forces landed on the beaches of Normandy in June 1944 and the public soon became aware of the detailed planning and preparations that had been made. Two complete pre-fabricated harbours, code named 'Mulberry' were towed across the channel and put together off the beaches to handle the 10,000 tons of supplies required each day. Inner and outer breakwaters were formed of a mixture of steel barges, concrete caissons and block ships to protect the floating pier heads which were anchored a mile offshore and connected by a flexible steel causeway supported on pontoons. The total quantity of steel involved ran to many thousands of tons, fabricated in workshops all over Great Britain and requiring formidable efforts in co-ordination.



Of course, getting an invading army ashore and continuing to supply it as it advanced involved the replacement of many bridges destroyed by the retreating enemy. Not all of these were Bailey Bridges, which were essentially for road use; some came from a stock of emergency replacement rail bridges held in this country, and some were constructed from a much stronger sectional truss bridge which would support railway loading over spans of 250 ft.

The Royal Engineers of the regular army were highly trained and officered by well-qualified engineers. They were quickly supplemented by companies of Territorials, by volunteers, and by conscripts, a great number of whom had a background in one of the many facets of the construction industry. In the front line were those whose jobs were clearing enemy mines, demolishing obstacles and building bridges using all the many and various types of equipment that had been fabricated for that purpose. Further away from the action there were camps to build, roads to repair, railways to be run, airstrips to build and all the multiplicity of tasks carried out by the Corps, justifying their boast that they were first in the field and last out.

Water supply was another of their responsibilities where, again, all sorts of devices had been designed or adapted to simplify the task in campaign conditions. One was the 'Braithwaite Tank'. These sectional tanks had been in use for many years and there had always been an argument about their origin. Some claimed the inventor to be Braithwaite but it could possibly be established that they had first been made from four foot square flanged cast iron plates by Horsley Bridge who subsequently developed their manufacture into pressed steel plates. Perhaps their patent was not quite as watertight as their tanks! Both before and after the war this product from both manufacturers found tremendous use in developing countries.

Although six years of war disrupted the lives of many young men, interrupting their education and careers and causing severe manpower shortages in industry, it must be said that all was not entirely detrimental for some of these men gained a new confidence and their experience, particularly in technical branches of the forces, was of some benefit in the resumption of their careers in civilian life.

The BCSA

In 1936, when the BCSA took over the reins from the British Steelwork Association, there was already in place, in addition to the promotional and commercial activities, a technical competence that expanded to provide help to both fabricator and customer. The bridgework design department, for example, offered help to local authorities to the extent, in some cases, of providing complete designs.

On the outbreak of war, the total capability of BCSA was offered to the relevant government departments who on many occasions, during the following six years, called for assistance in fulfilling urgent requirements.

At one time, the whole BCSA drawing office was engaged in converting ship builders' drawings into those more suitable to the fabricators' workshops. BCSA then arranged for its members to fabricate thirty thousand tons of components for dispatch to the shipyards.

Mention has already been made of bridges and barges, hangars and hulls for armoured cars and the various works for Mulberry harbour, all of which were handled by BCSA who matched requirements to capacity and capability in the allocation of work.

However, the efforts of the organisation and its members did not stretch to financial support for the government. Businesses still had to be run profitably since no-one benefited from patriotic bankruptcy and BCSA had many a tussle with the purchasing agents of a number of government departments who appeared to take a somewhat naïve view of the way in which a business was financed. No-one would argue about the duty to prevent people from taking advantage of wartime conditions to increase their profits, but the control was carried too far. For example, the maximum price that could be quoted was fixed by the Contracts Co-ordinating Committee of the Government who then imposed a costing clause on individual contracts, limiting the profit that could be made. Whilst this may not seem to be unreasonable, there was no provision for contracts which showed a loss – and there were many of them since the fabricators struggled with shortages of practically everything, delays in the provision of steel, disorganised transport, and perhaps most seriously, being sometimes called upon to carry out work which was not appropriate to their facilities.

The argument was never resolved and perhaps like most bodies subjected to regulation and control, the fabricators and their association found a sufficient number of loopholes to balance the books. Certainly, there is no evidence of companies being driven out of business, and it must be said that the fabricators, as a whole, emerged from the war in pretty good financial shape to face whatever the future had in store for them.

War-time activities of the BCSA included much useful work in acting for the industry in negotiation with government, not only on matters of payment and contract conditions, but also over interpretation of the many regulations that controlled the fabricators' activities. This naturally resulted in centralisation of power and a diminution in the role of the local associations who, nevertheless, still found that they had work to do in sorting out the often petty disputes which arose between contractors.

It is fair to say that the whole fabricating industry throughout the six-year period of national emergency performed with skill and determination. Within the bounds of the amount of steel that was allocated, all requirements were fulfilled, inexperienced labour was trained and ingenuity in design produced significant economies.

However, from the point of view of facilities, the industry found itself little further advanced than it had been in 1939. Workshops were in the same inefficient state, designed in days when labour was comparatively cheap, using equipment that had not changed in principle for fifty years.

One wartime development, however, was to have the most dramatic effect in future years, invented not for industrial use but as an aid to code breaking – the digital computer.

Post War Problems

The new Labour government set about the singularly difficult task of returning a country, which had been totally committed to war, as painlessly as possible to peace-time conditions. At the same time every effort had to be made to implement the promises of its election campaign. Mistakes were made, without doubt, but the six years of this administration had a profound and mainly beneficial effect on the country.

Some factors helped them to a good start. The people had grown accustomed to see Labour leaders in power in the Coalition government and there is no doubt that they had performed admirably. At the same time they had gained both experience and authority. Also, the public, who had cheerfully put up with a long period of shortage and restriction were, bolstered by the euphoria of victory, prepared to accept post war stringency, believing that this was the means to achieve all the good things that had been suggested if not exactly promised. They were also encouraged by the implementation of the proposals made by Sir William Beveridge in his 1942 report. The Welfare State came into being and, in spite of continuing political opposition and the immense amount of administration involved, the new government pushed the legislation through Parliament and set up the necessary institutions.

The first part of the Labour Party's programme, the nationalisation of key institutions and industries started at once. In 1946 the Bank of England, Civil Aviation, Cable and Wireless and the Coal Industry all came under state control, followed by Electricity, Gas and Transport in 1947. There was then a break of a couple of years before Iron and Steel was taken over although, in this case, legislation was delayed by the House of Lords and there was only time to put the Act into being, leaving the main firms intact for the Conservatives to return to private ownership when they were returned to power in 1951.

Sixty years later, when the philosophy of all political parties seems to be 'privatisation' it is easy to make distorted judgements of the years immediately after the war. It is arguable that both a Labour government and some degree of public control of major industries were very much in the national interest at that time. Unfortunately, expectations in taking over what was referred to as the 'Commanding Heights' of the economy were shattered when it was discovered that what had been purchased had very little potential profit to contribute.

The biggest problem that had to be faced was the financial exhaustion that the war had caused. Holdings of overseas investments were insufficient to provide us with necessities and it was vital that we exported as much as we possibly could even though there was a strong and continuing demand at home. The country seemed to lurch from one financial crisis to another while the home market was continuously deprived of those commodities that it was possible to sell abroad.

Salvation came in the form of the American Secretary of State, George C Marshall, whose plan for financial aid provided the stimulus which together with the success of the export drive and the benefit of full employment provided a vast improvement in the balance of payments. Even so, it was found necessary to devalue the pound from four dollars and three cents to two dollars and eighty cents, boosting the already increasing inflation.

Most people who lived through these years will remember it as a period when everything except cheerfulness and optimism was in short supply. Domestically, even wartime rationing of a number of commodities persisted to the end of the decade while industrially, there is little purpose in listing the commodities that were hard to obtain for it would have to include practically everything. One of the most intransigent shortages was manpower since men and women in the armed forces were not released to civilian life as quickly as expected; indeed 'National Service' persisted well into the 1950s, calling up young men at the age of eighteen or at twenty-one if they were serving an apprenticeship or were involved in further education. Also, people engaged on 'war work' found that instead of redundancy, many continued to manufacture armaments against the possibility of war with the communist states.

The Steel Industry

Peace found the industry in considerable turmoil. There were those who, remembering the short-lived boom after the First World War, advised a cautious approach to development and there were those who wanted to take advantage of the elimination of debt, brought about by the high levels of production during the war, and the prospect of profitable trading in the foreseeable future to create new efficiencies. On top of this was the promise of nationalisation, political interference over the siting of proposed new plant and the fierce independence of the steel makers.

But in spite of its inefficiency and the fact that it was operating old plant and equipment, which had been overworked for six years, it managed to hold on. The Treasury, incredibly short of dollars, had to find sufficient funds for the purchase of modern American plant, and in spite of all the factors weighing heavily against investment; companies began to carry out the plans for re-development that they had made during the war.

Nationalisation, when it did eventually come, was a half-hearted affair. The Labour government was, by this time, divided on the issue, indeed the agreement reached by Herbert Morrison that the Industry should be run under the control of a privately constituted Iron and Steel Board was later repudiated by a Cabinet committee. The delay in passing the bill through Parliament meant that there was insufficient time before the next general election to do more than take over the assets of the individual concerns and simply substitute the State for the original shareholders who in general were well compensated.

The argument had been three sided; the Government overcame the doubters in its ranks and, for the wrong reasons, went for nationalisation; to the Opposition this was simply a dirty word and the restoration of iron and steel to private ownership became a significant element of their electioneering platform without much understanding of the implications. Meanwhile the steel makers only wanted freedom either to amalgamate with others if there was a compelling reason or to continue to plough their lonely furrows, provided always that their prices were fixed at a level where the least efficient could make a living.

The Fabricating Industry

At the beginning of the war, the responsibility for regulating the prices of the various commodities that it had controlled, devolved from the Iron and Steel Federation to the Iron and Steel Control, a department of the Ministry of Supply and consequently, since the Federation had been responsible for regulating the minimum price agreement of the fabrication industry, this too became a government function. But with one significant difference – minimum prices now became maximum prices.

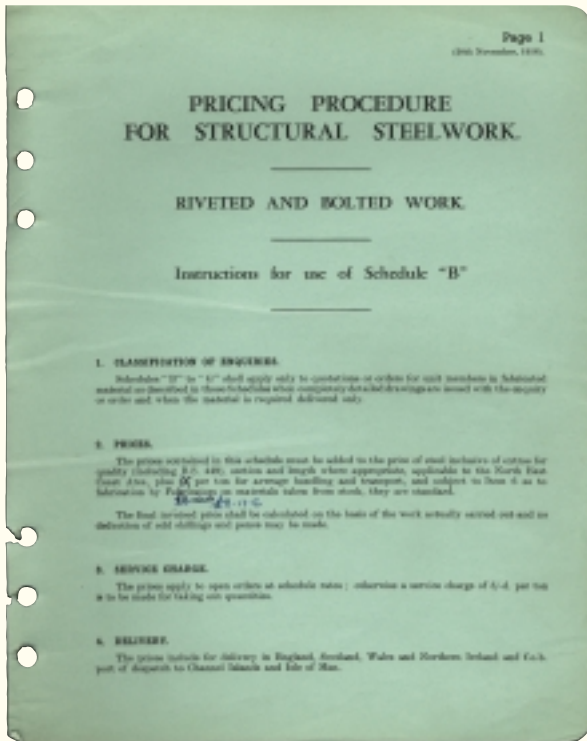

Peace brought a return to institutions and procedures but not in precise form and the re-constituted Iron and Steel Federation was no longer interested in some of what it considered to be peripheral activities, one of which was fabrication. The BCSA could have become an affiliated member but on balancing the rights and obligations it was decided that this was inappropriate.

The fabricators were thus left with a minimum price agreement but no regulatory body except their own trade association. But the problem was tackled directly by elected representatives of the industry who diligently set about a total review of the schedules, using the currently accepted figures as a basis in order to arrive at minima and maxima.

When it is considered that practically every steel structure is unique in size or shape or complexity of design, the task was virtually impossible but those who carried out the work must have had some belief in its validity. Figures were produced quite quickly with a rider that if a structure did not fit into a given category, members, with the authority of BCSA, could make appropriate additions. To avoid the Association becoming bogged down with a multiplicity of applications, if the addition was small it was left to the discretion of the members.

There is one further facet of the commercial arrangements of the fabricators that has not, hitherto, been mentioned and that is the agreement dating from the earliest days of the local trade associations that all enquiries must be reported. Members were then provided with a list of those on the 'file', as it was termed, making it very easy to consult with each other as to any addition to be applied to the standard rates. Of course, conversations were not limited to this one topic and it was not uncommon for the members to agree amongst themselves which of them should put in the lowest price. On the face of it, this may sound to be a somewhat dubious practice, but in general it worked quite well for the lowest price was not one that was inflated by the man who submitted it, but was controlled by his competitors who were certainly not going to allow him any great favours. The other advantage was, of course, that such circumstances effectively eliminated the Dutch auction.

In spite of the good intentions of those who supported and arranged these procedures, it has to be said that price schedules gradually eased and, in a booming market, more deals were done. In other words the system was eventually abused. It was quite common for the fabricators to quote prices that were absolutely identical and they had the naivety to suppose that this and other practices could carry on indefinitely. When the Monopoly (Inquiry and Control) Bill was promulgated in 1948, the BCSA immediately called in the lawyers but, strangely, were advised that provided members complied strictly with the rules of the Association they had nothing to fear. In spite of the omens that there were those in government raising questions on cartels and monopolies, and in spite of public and professional disquiet over reports of the fabricators' antics, nothing was done.

It must not be imagined that every contract went through these procedures for a surprising number were simply negotiated by the client directly or by his engineer or architect. Their viewpoint was simple and logical; if they went out to competitive tender they would quite probably get near enough the same price from everyone, therefore why not choose a fabricator who had given them good service, whose personnel they knew, and who understood what they required? The fabricator jealously guarded his regular customers, not daring to lift his prices, giving preferential service and only charging for variations and extras if they were of a substantial nature. In return, he more often than not enjoyed the privilege of better terms of payment and was protected from some of the wiles of the general contractor. There was also the case where the architect had to order steelwork at the earliest possible moment because deliveries were so long. Very often the structure was designed and in the process of manufacture before the main contract was placed. Whilst this was manna for the fabricators, it detracted from the main contractors' efforts in controlling and programming their work and it is hardly surprising that both builders and civil engineers mounted pressure against the practice.

Constant reference to competition, low prices, unfair purchasing practices and so on may give the impression that the fabricators were constantly on the brink of insolvency. Nothing could be further from the truth. Most companies had emerged from the war in quite good financial shape and it must be remembered that the minimum price agreements were pitched at a level such that even the inefficient could make a living. Companies with good facilities and management prospered, in spite of the disruption brought about by the shortage of labour and the uncertainties of supplies.

Featuring yet again was the continuing battle over 'simple fabrication', but this time with an added twist. In 1939 it was only a minority of steel makers who carried out complete structural contracts but during the war most used their fabrication facilities to the maximum and emerged as fully-fledged structural engineers, only too anxious to join the trade association, the BCSA. So now they wore two hats but probably because of their influence, at long last, after sixteen years of discussions, agreement was reached on the schedule of minimum rates. But even after all the time spent over these years some mills still sold simple sub-contract fabrication at knock-down prices; and some members of BCSA, probably most of them, were happy to enjoy the rewards whilst complaining about the practice.

Over this five year period trading returned to normality but not without a great deal of frustration, anxiety and sheer hard work in coming to grips with new legislation and the bureaucracy of controls. Companies were allocated a certain tonnage of steel and each building had to have a licence but, even with this paperwork in place, there was no guarantee that the required steel sections could actually be obtained. It was not unknown for substantial jobs to be delayed for the want of some small but important components although difficulties were often surmounted by borrowing, substituting or re-designing. Delays were inevitable but the customers were extraordinarily patient – much too patient sometimes as the excuse of 'waiting for material deliveries' was used to cover other inefficiencies. It was certainly not good for the industry that the sellers' market lasted for as long as it did.

Of course the return to peacetime trading had not been as abrupt as might be imagined. For the last twelve months of the war, military orders had been slowing down, allowing some throughput of 'civilian' work. It was also fortunate that the military orders did not cease immediately when the last shot was fired so that the transition was tolerably painless. Nevertheless, this was a time full of anxiety, for the world had changed radically and so many of the new uncertainties could have had disastrous results for the industry. Predominant in older men's minds was the recollection of appalling trading conditions shortly after the previous war. Also there was the promise of nationalisation of iron and steel, bringing into state ownership that substantial part of the fabrication industry already owned by the steelmakers. Would the independent sector be starved of material and slowly forced out of business? Or would they be priced out by the state sector at the taxpayer's expense?

Political statements were often bizarre, for example it was said that licences would not be available for industry or commerce since the whole building industry was to be diverted to constructing houses. It was also suggested that building licences should not be issued for steel framed buildings since the steel content of reinforced concrete was less. This was the beginning of a war between the two constructional systems and rather like the recent conflict it was one sided to begin with, but the fabricators fought back and ultimately gained a narrow victory although it took the best part of twenty years. Looking back, it is embarrassing to realise just how inefficient they were, but the fabricators actually thought that there was little improvement that they could make. But then the concrete men were probably not much better and on a purely price comparison there was not a lot to choose between them.

In spite of all the fears of shortage of work, the fabricators found themselves extremely busy in these years. The only limiting factor was material but there was sufficient to keep workshops running at levels requiring considerable hours of overtime. There was no predominant category of work; the whole infrastructure of the country needed repair and replacement and it was clearly going to take some time to build the necessary power stations and steelworks, to expand health and education services to cater for new legislation and, at the same time provide some capacity for private industrial and commercial development. The Butler Education Act of 1944 had raised the school leaving age which immediately required ten per cent additional places quite apart from the re-building of old premises. Designs had been created in anticipation and a number of standardised systems were considered, some using cold-rolled sections made from strip steel. These proved to be excellent in that they were quick to build and economical in the use of steel and although BCSA offered to build a competitive sample in hot rolled sections they were not encouraged. Even so, whilst the cold rolled sections predominated in single storey buildings, traditional frames catered well for those of two and three storeys and steel proved to be competitive since fire regulations deemed that schools did not need the normally specified concrete protection because in a disciplined environment, evacuation could be controlled.

The shortage of foreign exchange led to demands for greater exports and although steel was anything but plentiful, some was sold abroad in both plain and fabricated form. It must have been a delicate juggling act to strike a balance between the home and overseas markets but some countries needed help to replace bridges and transport facilities damaged in the war. One bridge exported to what was then Northern Rhodesia gave no problems in allocation for it started life as the wartime emergency bridge crossing the Thames at Westminster.

Although work at home tended to be of a utilitarian nature some excitement was allowed to creep in. The Festival of Britain used up 4,000 tons of precious steel in its main buildings although it was not officially opened until 1951 to celebrate the centenary of the rather more grandiose Great Exhibition in the Crystal Palace.



The BCSA

Emerging from the war with considerable credit for its hard work and commitment, the Association now faced a period equally complicated in the introduction of new legislation and in the controls that persisted. Members frequently needed the sort of advice that entailed discussion in government offices and the interests of the industry had to be furthered politically. Liaison with the government Steel Control and with the steel makers was another vital task to try and ensure a more ordered approach to the sequence of manufacture and to the restoration of rolling programmes. Then there was the ongoing work in refining and administering the minimum price agreement.

The more responsible members of the industry were seriously concerned that all was not well and through the Association did its best to give a lead in what had to be done. Surveys were carried out in the areas of efficiency, education and training but the lukewarm response from the industry must have been more than a little disheartening. However, work continued and was particularly valuable in the area of 'propaganda' which today we would probably call marketing. It was clear that the image and capability of the industry had to be projected both at home and abroad where the previously captive market of the colonial empire was beginning to disintegrate. There were some splendid glossy publications showing some of the very many contracts that had been carried out overseas and emphasising the size and capability of the Constructional Steelwork industry.

At the end of the decade, the Industry, collectively, had an order book stretching over a year ahead and had enjoyed, in spite of dire predictions to the contrary, five years of working to full capacity and at good prices. Prosperity brought complacency and the problems of inefficiency, lack of attention to training, poor contract conditions, competition from reinforced concrete and the attack that was about to be launched on the price fixing agreements, though not exactly ignored were not treated with sufficient urgency.

The preceding chapters provide an outline of the early history of the Steel Construction Industry and there are many people, even though some may no longer be actively involved, who are aware of subsequent happenings.

Certainly, the 1950s were pivotal insofar as dramatic change took place towards the end of the decade when the over-confidence, neglect and complacency of previous years led to a shake out of some of the less efficient companies in the first significant downturn in demand for twenty years. There followed a realisation amongst the more enlightened, that reorganisation was needed in every aspect of their businesses, if they were not going to follow their fallen brethren.

Additionally, the comfortable trading atmosphere of past years had lulled the fabricators into accepting conditions of contract that in more stringent circumstances were extremely onerous and which, even now, can cause considerable discomfort.

It would not be an exaggeration to say that this was the nadir of the industry. Everything went wrong. Inefficiencies in buildings and plant, in education and training, in productivity and labour relations, and particularly in management, all of which had been hidden by high demand and artificial pricing, were suddenly glaringly obvious and were exacerbated by the growing competition from reinforced concrete and, of course, the impact of the Monopolies Commission. It cannot be denied that there have subsequently been far greater upheavals and more dramatic

downturns in demand but at least in these later days the downfall of most companies was not so much due to their poor equipment or inefficiency as it was to their misguided commercial policies.

The fifties were followed by slow but positive progress in reorganisation until the introduction of the digital computer produced an unimagined acceleration and an enforced discipline. A brief summary of the subsequent developments is given in the following chapter written by Dr Derek Tordoff. As these years recede further into history, it is to be hoped that they too will be recorded with the attention to detail provided by Alan Watson in his story of the earlier years of our industry.

CHAPTER 9 – A BRIEF SUMMARY OF DEVELOPMENTS IN THE STEEL CONSTRUCTION INDUSTRY FROM THE 1950s TO 2000

By Derek Tordoff

In the late 1950s and early 1960s, three major developments helped the industry:

- the introduction of high strength bolts – one result of the combined effect of high strength bolts and arc welding was to virtually eliminate rivetting, both in the fabrication shop and on site.
- the rolling of Universal Beam and Column sizes – when introduced in 1962 immediately increased the ability to compete in overseas markets.
- the development in the use of digital computing in engineering – the computer provided a powerful tool to both designer and draughtsman. In the beginning this was used for the analysis of rigid frames, thus enabling the true potential of electric arc welding to be fully appreciated.

In the late 1960s the steelwork fabrication industry had a difficult time with the depression still continuing. The "freeze" was expected to thaw but devaluation, coupled with further cut-back in investment, served only to steepen the decline of order books, and thus increase the industry's spare capacity. Surplus capacity was tackled through encouraging a policy of planned rationalisation rather than allowing it to be reduced by economic accident.

By the early 1970s industry order books were in a healthier state due to an upsurge in demand. Some frustrations though existed for steelwork contractors due to the long delivery dates that were quoted by the rolling mills. Improved trading conditions were expected to continue for some time, but an inflationary spiral gripped the country and precipitated demands for substantial increases in wages and salaries, and also exceptional increases in the cost of raw steel and of other materials, thus creating problems for steelwork contractors.

In 1972 the UK entered the European Economic Community and the BCSA achieved closer ties with Continental steel makers through the European Commission and the European Convention for Constructional Steelwork. Closer and more practical liaison was established with the British steel makers with regard to steel mills' performance, steel qualities, prices and the basing point system.

1974 saw the long awaited cyclical recovery, confidence was buoyant. The steel industry had been nationalised in 1966 and the resulting British Steel Corporation agreed plans with the BCSA to ensure a steady build-up of supplies for steelwork contractors in spite of the world-wide demand for steel which had developed. At home the new Corporation had ambitious plans itself for increasing and modernising its steel-making capacity, including one scheme – Anchor – that alone required 40,000 tonnes of steelwork at Scunthorpe. Several schemes were only part-complete when the short-lived optimism was dealt a double blow of suddenly increased oil prices and of serious industrial disputes, leading to the three-day power week and a change in government. This was a testing time for both the steelwork fabricators and the BCSA. The legacy in terms of the UK steel industry was that it had some modern facilities, most notably the continuous casting process that provided much

better quality products. Other investments languished such that the second blast furnace for Redcar lay in pieces for many years until it was sold eventually to Brazil.



1979/1980 was the worst year (known at that time) since the 1930s in the structural steelwork industry. A worsening economic climate accompanied by two severe periods of industrial disruption hit the fabricators hard. There was a three month engineering dispute which reduced working to three days per week, and this was followed by a total strike in the British Steel Corporation that completely stopped production of steelwork contractors' basic raw material for three months. Many companies ceased to trade either voluntarily or by forced closure. Those fabricators remaining faced a fiercely competitive situation with uneconomic price levels and severe financial pressures.

In the early 1980s many companies invested heavily in new plant and buildings so that the industry would be well equipped for the next boom, then they suffered from inviable price-cutting as they strived to keep their workforce intact during the storm. The recession was seen as a challenge as well as a threat. Improved productivity, a high level of capital investment in workshop machinery and computer aids, more efficient management, closer attention to marketing – all contributed to a revival in confidence in steel in construction as a cost-effective and speedy solution to clients' requirements. There was a determination amongst steelwork contractors to continue to improve competitiveness, to increase efficiency and to enlarge the available market.

With considerable support from the British Steel Corporation's technical marketing campaigns, steel's popularity continued to grow. In the mid-1980s the overall efficiency, competitiveness

and quality of steel-framed construction became increasingly recognised. 1985 saw a large resurgence of interest in steel construction which was achieved not only because of fundamental economic factors, but also because of various technical innovations, such as profiled steel sheet decking, lightweight fire protection, and the introduction of the FASTRAK 5950 suite of computer programs.

1985 also saw the industry's efforts to put its house in order, by way of improvements in quality, responsible wage settlements, quick and reliable on-site erection. These were rewarded when, for the first time in over half of century, steel superseded in-situ concrete as the most popular form of construction for multi-storey buildings. There was a massive recovery in the quantity of steelwork fabricated from 700,000 tonnes in 1983 to close on 1,000,000 tonnes in 1986.

By the end of the 1980s British Steel Corporation had been de-nationalised and had become an efficient steel producer by world standards of productivity. In later years the globalisation of the world steel market led to rationalisation amongst the players and BSC merged with Koeniglijk Hoogovens to become Corus Plc.

In response to numerous requests, and after lengthy consultation and discussion, 1987 saw an amendment to the BCSA's membership rules which ratified the opening up of membership to other trading companies which subscribed to the BCSA's aims and objectives – such companies would be known as Associate Members.

In 1989 the industry's output peaked at 1,400,000 tonnes. Also in 1989 the BCSA launched the National Structural Steelwork Specification for Building Construction (the "Black" Book) with the aim of achieving greater uniformity in contractual project specifications and eliminating the plethora of conflicting requirements which were faced by the industry.



The early 1990s saw the industry in recession again. There was a significant drop in the production of structural steelwork. All companies suffered greatly and many ceased trading. The industry, the backbone of construction, faced a difficult situation – attacked from all sides, unable to control its present and unable to plan its future. Most notably companies in the steel construction sector suffered severely when several large London property developers got into trouble.

But even in the difficult times the industry continued to move forward; in the home market steel's market share of buildings of two or more storeys increased from 57% in 1992 to an all-time record high of 62% in 1993. As a part of its continuing marketing campaign, BSC had reorganised Constrado to form the Steel Construction Institute with the aim of improving the technical advice about steel available to potential specifiers.

By 1994 it was generally felt that an improvement in the industry's fortunes was on its way. Sir Michael Latham's review of procurement and contractual arrangements had commenced and promised to be a watershed for the entire construction industry – starting a return back to good practices that could only benefit the industry.

Exports saw a dramatic leap in the early 1990s with companies proving that the UK has the world's best steel construction industry by winning orders all around the globe. The BCSA organised a successful mission to the People's Republic of China in 1994 and several steelwork contractors won orders to work in China.

1995 saw the launch of the Register of Qualified Steelwork Contractors Scheme which was set up with the aim of improving competitiveness and efficiency in the steel construction industry by ensuring satisfaction, readily enabling identification of appropriate steelwork contractors and ensuring that competition takes place within a set level of competence and experience.

The late 1990's saw improvements to the commercial environment with the elimination of cash retentions on steel construction contracts and in 1998 the first of the annual Steel Construction Industry Directory for Specifiers and Buyers was published. In 1999 over 1,000 delegates from 26 countries came to London for BCSA's International Steel Construction Conference and Exhibition, culminating with a Millennium Banquet held at Guildhall with HRH The Princess Royal as the Principal Guest. 2001 saw the launch of the Safer Steel Construction Programme, encompassing a number of new initiatives to cut accidents in the factory and on the site, such as the Safe Site Handover Certificate.

At the beginning of this new millennium steel's share of multi-storey buildings is at an all time record level of almost 70%. New market opportunities are opening up for the industry in car parks, hospitals, schools, and multistorey residential construction

But what of the future ...?

The Industry's future must rest in the hands of individual steelwork contractors whose strengths and deficiencies will mark the limits of its advance. The BCSA can commission surveys, institute comparison schemes and take many other steps for the benefit of steelwork contractors, but it is the industry itself which must act, take advantage of what is offered and ensure that the BCSA continues to serve them to best advantage.

References

General

Note that web addresses and contact details of publishers of all references given are locatable through a conventional internet search

Black Book: National Structural Steelwork Specification for Building Construction, 4th Edition, BCSA/SCI P-203

Grey Book: Commentary on the National Structural Steelwork Specification for Building Construction, 4th Edition, BCSA/SCI P-209

Red Book: Handbook of Structural Steelwork, 3rd Edition, BCSA/SCI P-201

Blue Book: Steelwork Design Guide to BS 5950-1:2000. Volume 1 – Section properties & member capacities, BCSA/SCI P-202

Green Books:

Joints in Steel Construction: Moment Connections, BCSA/SCI P-207

Joints in Steel Construction: Simple Connections, BCSA/SCI P-212

Joints in Steel Construction: Composite Connections, BCSA/SCI P-213

BS 5950-1 Structural use of steelwork in building. Code of practice for design. Rolled and welded sections

BS 5950-2 Structural use of steelwork in building. Specification for materials, fabrication and erection. Rolled and welded sections

BS EN 10025 Hot rolled products of non-alloy structural steels (title of 1993 version, but being issued as an amended version that covers in addition all structural steel grades previously included in BS EN 10113, BS EN 10137 and BS EN 10155)

Chapter 1 Introduction to Steel Construction

None

Chapter 2 Design

Construction (Design and Management) Regulations

BS 4-1 Structural steel sections. Specification for hot rolled sections

BS 6399-1 Loadings for buildings. Code of practice for dead and imposed loads

BS 6399-2 Loadings for buildings. Code of practice for wind loads

BS 6399-3 Loadings for buildings. Code of practice for imposed roof loads

BS EN 10034 Hot rolled steel I and H sections. Tolerances on shape and dimensions

BS EN 10056 Specification for structural steel equal and unequal angles

BS EN 10210 Hot finished structural hollow sections of non-alloy and fine grain structural steels

BS EN 10279 Hot rolled steel channels. Tolerances on shape, dimension and mass

Chapter 3 Single Storey Buildings

Plastic Design to BS 5950, J M Davies & B A Brown, Blackwell Science

Building Design using Cold Formed Sections: Construction Detailing and Practice, SCI P-165

The Designers Guide to Insulated Roof & Wall Panel Systems – Building Envelope Solutions, Ward Building Components Ltd

Chapter 4 Multi-Storey Buildings

BS 6472 Guide to evaluation of human exposure to vibration in buildings (1 Hz to 80 Hz)

Design Guide on the Vibration of Floors, SCI P-076

Chapter 5 Connections

Section Capacities and Member Resistances to Eurocode 3 (UB, UC and hollow sections), SCI P-158

Chapter 6 Steel Manufacture

None

Chapter 7 Steel Specification

BS EN 10210 Hot finished structural hollow sections of non-alloy and fine grain structural steels

BS EN 10219 Cold formed welded structural hollow sections of non-alloy and fine grain steels

Chapter 8 Plated Beams

BS 5950-3-1 Structural use of steelwork in building. Design in composite construction. Code of practice for design of simple and continuous composite beams

Steel Designers' Manual, 6th Edition, Blackwell Science/SCI P-062

Design of Fabricated Composite Beams in Buildings. SCI P-059

Design Guide on the Vibration of Floors, SCI P-076 (see also subsequent Advisory Desk articles in BCSA/SCI New Steel Construction magazine)

Dynamics of Structures, R W Clough & J Penzien, McGraw-Hill

Design for Openings in the Webs of Composite Beams, SCI P-068

BS 5950-8 Structural use of steelwork in building. Code of practice for fire resistant design

Yellow Book: Fire Protection for Structural Steel in Buildings, 3rd Edition, ASFP/SCI P-013

Chapter 9 Welding

BS EN 1011-1 Welding. Recommendations for welding of metallic materials. General guidance for arc welding

BS EN 1011-2 Welding. Recommendations for welding of metallic materials. Arc welding of ferritic steels

BS EN 22553 / ISO 2553 Welded, brazed and soldered joints. Symbolic representation on drawings

BS EN 29692 / ISO 9692 Specification for metal-arc welding with covered electrode, gas-shielded metal-arc welding and gas welding. Joint preparations for steel

BS EN ISO 4063 Welding and allied processes. Nomenclature of processes and reference numbers

BS EN 288-2 Specification and approval of welding procedures for metallic materials. Welding procedures specification for arc welding

BS EN 288-3 Specification and approval of welding procedures for metallic materials. Welding procedure tests for the arc welding of steels

BS EN 287-1 Approval testing of welders for fusion welding. Steels

BS EN 970 Non-destructive examination of fusion welds. Visual examination

BS EN 1290 Non-destructive examination of welds. Magnetic particle examination of welds

BS EN 1714 Non-destructive examination of welded joints. Ultrasonic examination of welded joints

Chapter 10 Bolting

Brown Book: Structural Fasteners and their Application, BCSA Publication 4/78

BS 3692 ISO metric precision hexagon bolts, screws and nuts. Specification (Superseded 2001)

BS 4190 ISO metric black hexagon bolts, screws and nuts. Specification

BS 4395-1 Specification for high strength friction grip bolts and associated nuts and washers for structural engineering. General grade

BS 4395-2 Specification for high strength friction grip bolts and associated nuts and washers for structural engineering. Higher grade bolts and nuts and general grade washers

BS 4604-1 Specification for the use of high strength friction grip bolts in structural steelwork. Metric series. General grade

BS 4604-2 Specification for the use of high strength friction grip bolts in structural steelwork. Metric series. Higher grade (parallel shank)

BS EN ISO 898-1 Mechanical properties of fasteners made of carbon steel and alloy steel. Bolts, screws and studs

BS 7644-1 Direct tension indicators. Specification for compressible washers

BS 7644-2 Direct tension indicators. Specification for nut face washers and bolt face washers

AD 268 Bolt Lengths – Table 3 BS 5950-2: 2001, BCSA/SCI New Steel Construction magazine November/December 2003 Edition

Chapter 11 Fabrication

Design for Manufacture Guidelines, SCI P-150

Design of Curved Steel, SCI P-281

The Procedure Handbook of Arc Welding, The Lincoln Electric Company

Chapter 12 Corrosion Protection

BS EN ISO 12944-2 Paints and varnishes. Corrosion protection of steel structures by protective paint systems. Classification of environments

ISO 9223 Corrosion of metals and alloys. Corrosivity of atmospheres. Classification

BS EN ISO 12944-3 Paints and varnishes. Corrosion protection of steel structures by protective paint systems. Design considerations

PD 6484 Commentary on corrosion at bimetallic contacts and its alleviation

BS 8110-1 Structural use of concrete. Code of practice for design and construction

BS EN ISO 14713 Protection against corrosion of iron and steel in structures. Zinc and aluminium coatings. Guidelines

BS 4479-7 Design of articles that are to be coated. Recommendations for thermally sprayed coatings

BS 7079-A1 / ISO 8501-1 Preparation of steel substrates before application of paints and related products. Visual assessment of surface cleanliness. Specification for rust and preparation grades of uncoated steel substrates and of steel substrates after overall removal of previous coatings

BS 7079-B3 / BS EN ISO 8502-3 Preparation of steel substrates before application of paints and related products – Assessment of dust on steel surfaces prepared for painting (pressure-sensitive tape method)

BS 7079-A3 / ISO 8501-3 Preparation of steel substrates before application of paints and related products. Visual assessment of surface cleanliness. Preparation grades of welds, cut edges and other areas with surface imperfections

BS EN ISO 1461 Hot dip galvanized coatings on fabricated iron and steel articles. Specifications and test methods

BS EN 22063 / ISO 2063 Metallic and other inorganic coatings. Thermal spraying. Zinc, aluminium and their alloys

BS 7371-6 Coatings on metal fasteners. Specification for hot dipped galvanized coatings

The Prevention of Corrosion on Structural Steelwork: A Corrosion Protection Guide, Corus Publication

Part C - For steelwork exposed to atmospheric environments

Part D - For steelwork in building interiors & perimeter walls

Part E - For steelwork in indoor swimming pool buildings

BS 7513 / EN 45013 General criteria for certification bodies operating certification of personnel

Chapter 13 Fire Resistance

Fire Resistance of Steel Framed Buildings, Corus Publication

Engineered Steel Braces Fire, Corus Publication

Structural Fire Safety: A Handbook for Architects and Engineers, SCI P-197

Design of Steel Framed Buildings without Applied Fire Protection, SCI P-186

Framed in Steel: The Technology Partnership Development Centre and Corporate Headquarters, Corus Publication

Building Regulations: Approved Document B, HMSO

Building Standards (Scotland) Regulations: Technical Standards, HMSO

Northern Ireland Building Regulations: Technical Booklet E, HMSO

London District Surveyors Fire Safety Guide No. 1: Fire Safety in Section 20 Buildings, LDSA Publications

Health Technical Memorandum 81: Fire Precautions in New Hospitals, HMSO

BS 5588-10 Fire Precautions in the design, construction and use of buildings. Code of practice for shopping complexes

BS 7974 Application of fire safety engineering principles to the design of buildings. Code of practice

Fire Safe Design: A New Approach to Multi-Storey Steel-Framed Buildings, SCI P-288

BS 5950-8 Structural use of steelwork in building. Code of practice for fire resistant design

BS EN 1991-1-2 Actions on structures. Actions on structures exposed to fires

BS EN 1993-1-2 Design of steel structures. Structural fire design

BS EN 1994-1-2 Design of composite steel and concrete structures. Structural fire design

Reinstatement of Fire Damaged Steel and Iron Framed Structures, Corus Swinden Technology Centre Publication

Single Storey Steel Framed Buildings in Fire Boundary Conditions, SCI P-313

BS 5306-2 Fire extinguishing installations and equipment on premises. Specification for sprinkler systems

Use and Benefits of Incorporating Sprinklers in Buildings and Structures, BASA

Chapter 14 Erection

Design for Construction, SCI P-178

Interfaces: Steel Supported Glazing Systems, SCI P-193

Interfaces: Connections between Steel and Other Materials, SCI P-102

Interfaces: Curtain Wall Connections to Steel Frames, SCI P-101

Interfaces: Design of Steel Framed Buildings for Service Integration, SCI P-166

Interfaces: Electric Lift Installations in Steel Framed Buildings, SCI P-103

Chapter 15 Specification and Quality

Method of Survey, BRE/CIRIA

Execution of Steelwork to EC3 – ENV 1090-1, ECCS Publication 93

DD ENV 1090-1 Execution of steel structures (to be superseded by BS EN 1090-2)

National Building Specification, NBS

Chapter 16 Information

Efficient Steelwork Procurement through Improved Information Exchange, CICA/BCSA

Chapter 17 Software

How solid is that paper wall? R Dobson, The Structural Engineer, 3 July 2001, Vol 79 No 13

Productivity in 3D modeling and structural design, A Miller, The Structural Engineer, 5 February 2002, Vol 80 No 3

Is your design office ready for new IT challenges? R Dobson, The Structural Engineer, 1 April 2003, Vol 81 No 7

CIS/2 Home page <http://www.cis2.org/>

CIS/2 Implementations <http://www.coa.gatech.edu/~aisc/>

IAI Home page <http://www.iai-international.org>

IAI Implementation <http://www.bauwesen.fh-muenchen.de/iai/ImplementationOverview.htm>

Bentley's White Paper on the Building Information Modelling Debate http://www.bentley.com/files/industry_groups/building/bim_white_paper.pdf

AutoDesk's White Paper on Building Information Modelling Debate http://www3.autodesk.com/adsk/files/3085461_BIM_WP_Rev7.pdf

Chapter 18 Selection of Steelwork Contractors and Suppliers

None

Chapter 19 Contracts and Payments

Orange Book: Contractual Handbook, BCSA 32/01

Quality Control on Building Sites, BRE

Accelerating Change, Rethinking Construction, ISBN 1 898671 28 1, HMSO

The Use of Retentions in the UK Construction Industry, SECG evidence submitted to the House of Commons Trade and Industry Committee Report Second Report of Session 2002-3, HC127

Chapter 20 Health & Safety

Safer Erection of Steel-Framed Buildings: Guidance Notes, BCSA

BS 5531 Code of practice for safety in erecting structural frames

Chapter 21 Sustainable Construction

Sustainable Steel Construction: Building a Better Future, BCSA/SCI-EP33

Chapter 22 Building Envelope

BS 5427-1 Code of practice for the use of profiled sheet for roof and wall cladding on buildings. Design

Building Regulations: Approved Document L2, HMSO

BS EN 12056-3 Gravity drainage systems inside buildings. Roof drainage, layout and calculation (supersedes BS 6367 Drainage of roofs and paved areas)

Fire Performance of Sandwich Panel Systems, ABI

BS 6399-1 Loadings for buildings. Code of practice for dead and imposed loads

BS 6399-2 Loadings for buildings. Code of practice for wind loads

BS 6399-3 Loadings for buildings. Code of practice for imposed roof loads

Guidance for the design of metal roofing and cladding systems to comply with Approved Document L2: 2001, MCRMA Technical Paper 14

Abbreviations

ABI	Association of British Insurers	EAF	Electric Arc Furnace
ACE	Association of Consulting Engineers	ECCS	European Convention for Constructional Steelwork
AD	Approved Document	ECITB	Engineering Construction Industry Training Board
AISC	American Institute of Steel Construction	EDI	Electronic Data Interchange
ASFP	Association for Specialist Fire Protection	EN	European Standard
ASTM	American Society for Testing and Materials	ENV	European Pre-Standard
BCSA	British Constructional Steelwork Association	FCAW	Flux-Cored Arc Welding
BOS	Basic Oxygen Steelmaking	FLS	Fire Limit State
BRE	Building Research Establishment	GDP	Gross Domestic Product
BREEAM	BRE Environmental Assessment Method	H&S	Health & Safety
BS	British Standard	HAZ	Heat-Affected Zone
BSRIA	Building Services Research and Information Association	HGCR	Housing Grants, Construction & Regeneration (Act)
BSI	British Standards Institution	HSE	Health & Safety Executive
CAD	Computer Aided Design	HSFG	High Strength Friction Grip (Bolt)
CAM	Computer Aided Manufacture	HSW	Health and Safety at Work (etc Act)
CEN	European Standards Organisation	IAI	International Association for Interoperability
CIC	Construction Industry Council	ICE	Institution of Civil Engineers
CICA	Construction Industry Computing Association	IFC	Industry Foundation Classes
CIRIA	Construction Industry Research and Information Association	ISE	Institution of Structural Engineers (also IStructE)
CIS	CIMsteel Integration Standards	ISO	International Standards Organization
CITB	Construction Industry Training Board	JCT	Joint Contracts Tribunal
CNC	Computer Numerically Controlled	KPI	Key Performance Indicator
CDM	Construction Design & Management	LCA	Life Cycle Assessment
CEV	Carbon Equivalent Value	LCC	Life Cycle Costing
CHS	Circular Hollow Section	LPC	Loss Prevention Council
CHSW	Construction (Health & Safety at Work) Regulations	LTB	Lateral-Torsional Buckling
CPD	Construction Products Directive	M&E	Mechanical & Electrical
CSCS	Construction Skills Certification Scheme	MCRMA	Metal Cladding and Roofing Manufacturers Association
CVN	Charpy V-Notch (Test)	MEWP	Mobile Elevating Work Platform
D&B	Design & Build	MAG	Metal Active Gas (Welding)
DBME	Design-Basis Method of Erection	MIG	Metal Inert Gas (Welding)
DD	Draft for Development (preliminary BS)	MIS	Management Information System
DIS	Draft International Standard	MMA	Manual Metal Arc (Welding)
DOM	Domestic (Subcontract)	MPI	Magnetic Particle Inspection
DPI	Dye Penetrant Inspection		

NC	Numerically Controlled
NDE	Non-Destructive Examination
NDT	Non-Destructive Testing
NSSS	National Structural Steelwork Specification (for Building Construction)
NVQ	National Vocational Qualification
PD	Published Document (by BSI)
PFC	Parallel-Flanged Channel
pWPS	preliminary Welding Procedure Specification
Q&T	Quenched & Tempered (Steel)
QA	Quality Assurance
QC	Quality Control
RHS	Rectangular Hollow Section
RIBA	Royal Institute of British Architects
RQSC	Register of Qualified Steelwork Contractors
RSA	Rolled Steel Angle
SAW	Submerged Arc Welding
SCCS	Steel Construction Certification Scheme
SCI	Steel Construction Institute
SDNF	Steelwork Detailing Neutral Format
SECG	Specialist Engineering Contractors' Group
SHS	Square Hollow Section
SI	Système International
SLS	Serviceability Limit State
SMM	Standard Method of Measurement (for Building Construction)
SSDA	Structural Steel Design Awards
TC	Technical Committee
TCB	Torque-Controlled Bolt
TMR	Thermo-Mechanically Rolled (Steel)
TWI	The Welding Institute
UB	Universal Beam
UC	Universal Channel
ULS	Ultimate Limit State
U/S	Ultrasonic
UT	Ultrasonic Testing
WPAR	Welding Procedure Approval Record
WPS	Welding Procedure Specification