

# Steel Intelligence



## HEADLINE SPONSORS



## GOLD SPONSORS

AJN Steelstock Ltd  
 Ficep UK Ltd  
 Kingspan Limited  
 National Tube Stockholders and  
 Cleveland Steel & Tubes  
 ParkerSteel  
 voestalpine Metsec plc  
 Wedge Group Galvanizing Ltd

## SILVER SPONSORS

Hadley Group, Building Products  
 Division  
 Jack Tighe Ltd

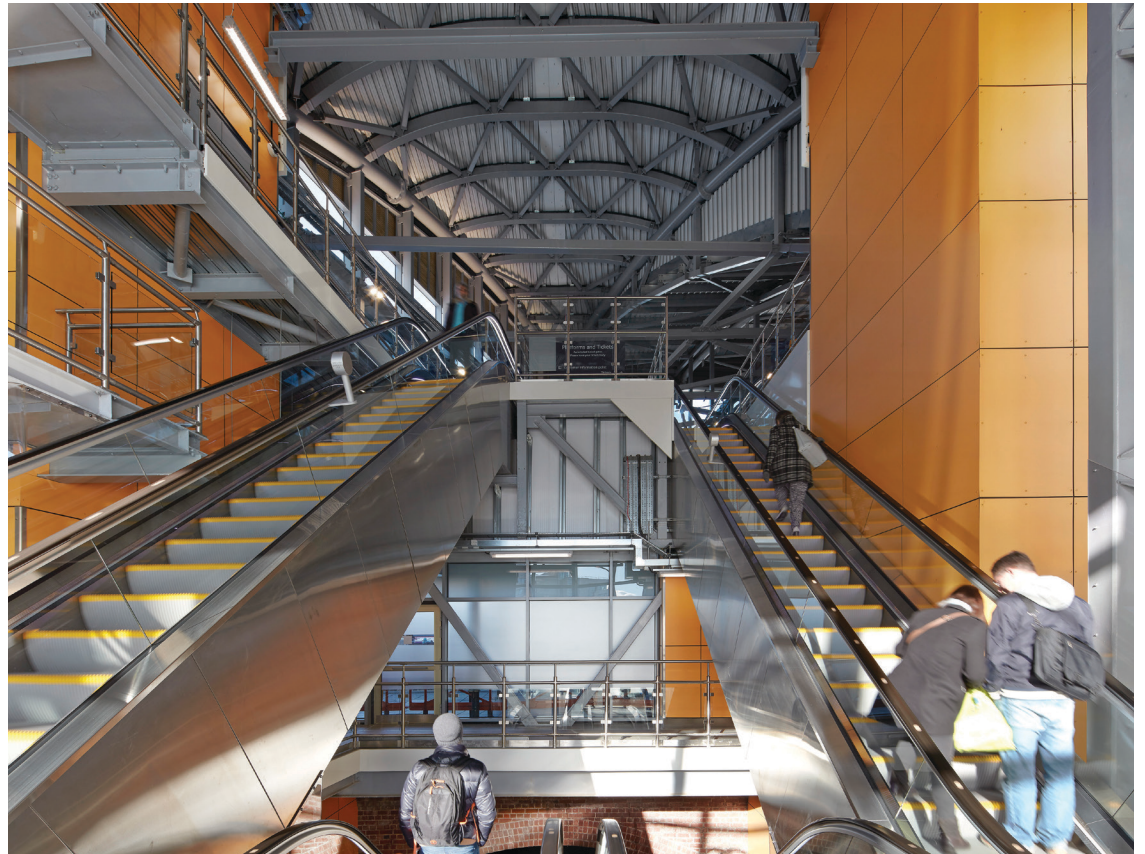

AHR/DANIEL HOPKINSON

Is it possible to future-proof buildings? How can clients ensure they remain assets rather than white elephants? In this issue of Steel Intelligence we consider long spans (p81) and how the increased flexibility of use they provide might aid building longevity. Our two project studies offer sharp contrasts in scale and nature. Make's steel-clad and steel-framed groundscraper 5 Broadgate provides some of the largest floorplates in the City of London (p83). In Leeds, AHR's challenge was to create a much-needed additional entrance to the railway station while building over both a river and live railway tracks (p78 and above). Also on a railway theme, in our icon slot (p86) engineer Chris Wise admires Isambard Kingdom Brunel's 'inspirational' Royal Albert Bridge at Saltash, completed shortly before his death in 1859.

**Pamela Buxton, editor, Steel Intelligence**





# A river runs through it

A golden hood over the River Aire now beckons commuters to the new southern entrance of Leeds Station and provides a landmark for a fast regenerating area, belying the construction difficulties posed by such a tight site

**Words** Pamela Buxton **Photographs** AHR/Daniel Hopkinson

**Leeds Station's** £20 million new entrance presented multiple special challenges: piling down into the bed of the River Aire, building up over live railway tracks, managing a sensitive interface with a Victorian structure, and negotiating a heavily restricted site which meant building components had to be brought in by barge.

Following a concept design by Bauman Lyons Architects, the project was developed in detail by architect AHR and structural engineer Mott MacDonald with steelwork by William Hare. Clad in golden, anodised aluminium panels, the intervention creates a new city centre landmark as well as serving the fast-regenerating area south of the station.

'The hope was to create an iconic entrance for the city – something attractive rather than run-of-the-mill,' says AHR architect Matt Beaumont.

'It was an extremely challenging project in all senses. Everything had to be fabricated offsite, then sailed up river by barge, and winched into place by a tower crane positioned behind a tall neighbouring building. And it had to be millimetre perfect.'

The only viable location for the new entrance was to build directly over the fast-flowing River Aire alongside the railway viaduct. The new structure contains stairs, lifts and escalators rising 12m to connect to the existing high-level concourse.

A prefabricated steel structure was judged the best and most practical way of realising the entrance's distinctive hooded form while limiting onsite construction.

'Steel was the only way to achieve the tight structural zone and sweeping curve of the entrance,' says Mott MacDonald senior structural engineer Jonathan Svikis.

The preference for prefabrication also drove the decision to use bolted connections, with every one tested during pre-erection trials offsite.

'Normally the structure would have been welded but because we're working above the river and railway it needed to be something that could be erected quite quickly on site,' he says.

Mott MacDonald piled foundations and built two piers in the middle of the river. These were positioned to align with the rail viaduct arches so as not to impede the water flow, and to rise high enough to clear a 1 in 200 year flood event. The piers support a steel transfer deck (see overleaf) of galvanized beams which in turn supports the primary structure of the new entrance (see right).

During the detailed design process Mott MacDonald and AHR realised they'd need to reduce the structural zone to 400mm from the 700mm of the initially proposed curved portal frame concept structure, in order to



**Left** Passengers have views of the exposed diagrid steel structure as well as the River Aire as they travel on the escalators.

**Above** A steel structure was the only way to achieve the distinctive hooded form of the new entrance within the restricted site.

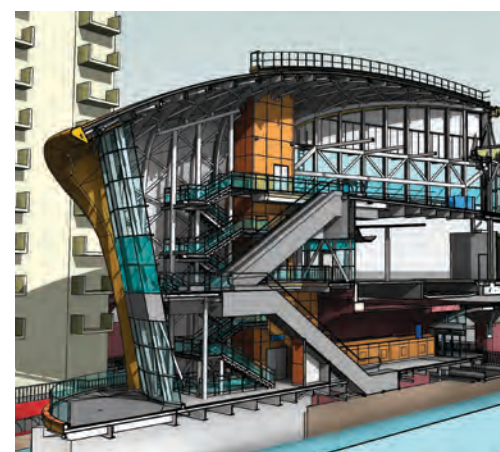

## PORTAL FRAME

The portals rise to 20m tall, each with a horizontal span of approximately 12.5m and spaced at 1.8m intervals. For ease of manufacture and transportation, all but the smallest of the frames are divided into four parts – two 400mm x 200mm RHS columns and two rafters of the same size spliced at the highest point of the curve. These have radii ranging from 2.8m to 12.3m to support the required roof profile. The curved rafters were bolted together in the assembly yard downriver before being brought to site by barge and lifted on to the columns. The frames are braced out of plane with diagonal 120mm x 120mm x 5mm square hollow sections to form a diagrid structure over the sides and curved roof of the entrance. There are 11 frames at river deck level and a further 9 extending over three railway lines to form the connection to the higher concourse level.

accommodate all the internal elements.

But with the boundaries of the building fixed, the design team utilised parametric modelling to run curvature analysis, and used this to inform a redesign of the frame. This led to the replacement of the chunkier I-sections with closer-spaced RHS hoops and rafters to give a less faceted, more curved profile and, crucially, the introduction of a diamond-patterned diagrid structure. As well as reducing the structural zone straight away, this structure gave a strong architectural expression to the interior of the building when exposed, according to Beaumont. More drama is added by striking views over the river through the fully glazed entrance facade from the top of the escalators and stairs, although the Schueco system incorporates strategic opaque panels to discourage congestion at mezzanine level.

At the top of the entrance structure, a new upper passenger level with ticket barriers was built above platforms 15, 16, and 17 to join the existing concourse bridge. This is hung from two primary trusses spanning 17.7m and 19.5m. Spliced for ease of lifting, they were installed during weekend rail possessions. Additional support is provided by a new column on Platform 15 on top of the Victorian structure. To accommodate the extra load of the new upper level, one of the viaduct's quadripartite arches was strengthened with four curved plate girder

ribs on the underside of the arches, each tied back into the masonry with 1m long anchors. To ensure a perfect fit, the engineer carried out a point cloud survey of the existing arch and integrated that into the steelwork model before fabrication.

Use of BIM was vital to such a complex project where the design team was working within a 50mm tolerance for the structure. It was also useful for communicating key details to the client, construction and maintenance teams.

'Without BIM it would've been almost impossible to do because of the high number of constraints,' says Jonathan Svikis. 'We'd have taken two or three times longer to get to the fabrication stage.' He adds that William Hare was able to use the BIM model as the starting point for its steelwork details.

'It hasn't been the biggest project but is definitely the most challenging and intricate,' Svikis says.

'It was a very unusual job to work on – tricky but interesting,' says William Hare project manager Sue Wadsworth. 'Normally there might be some element of complexity amid the normal. But there, it was the other way round.'

The new entrance is estimated to save one-fifth of the 20,000 users of the station up to 50 minutes a week. Incorporating 370t of steel, the project won the steel category of the UK Tekla Awards 2015. ●

#### Credits

**Client:** Network Rail, West Yorkshire Combined Authority

**Architect:** AHR (concept design by Bauman Lyons Architects)

**Structural engineer:** Mott MacDonald

**Steelwork contractor:** William Hare

**Principal Contractor:** Carillion Rail

#### TRANSFER DECK

A series of galvanized beams, positioned at 1.8m centres, forms the deck. These span 10.2m between the new concrete piers and cantilever a further 3.5m beyond the centre line of each pier to support the columns above. The 650mm deep deck terminates in a curved southernmost end, which cantilevers 2.3m beyond the southernmost primary beam. The engineers explored precast and in-situ concrete options but found prefabricated steel to be the most practical solution, especially for a winter installation. Two upstand trusses measuring 2.1m deep extend 15m from the transfer deck through the viaduct to provide a pedestrian route to the street behind. Access to the east and west riverbanks was provided by two welded, box section footbridges. The transfer deck was constructed in about two weeks.



# How far can you go?

The demand for long single spans to provide column-free space is spreading beyond the financial services and leisure sectors as clients seek greater flexibility in their assets

**Words** Pamela Buxton **Illustration** Toby Morison

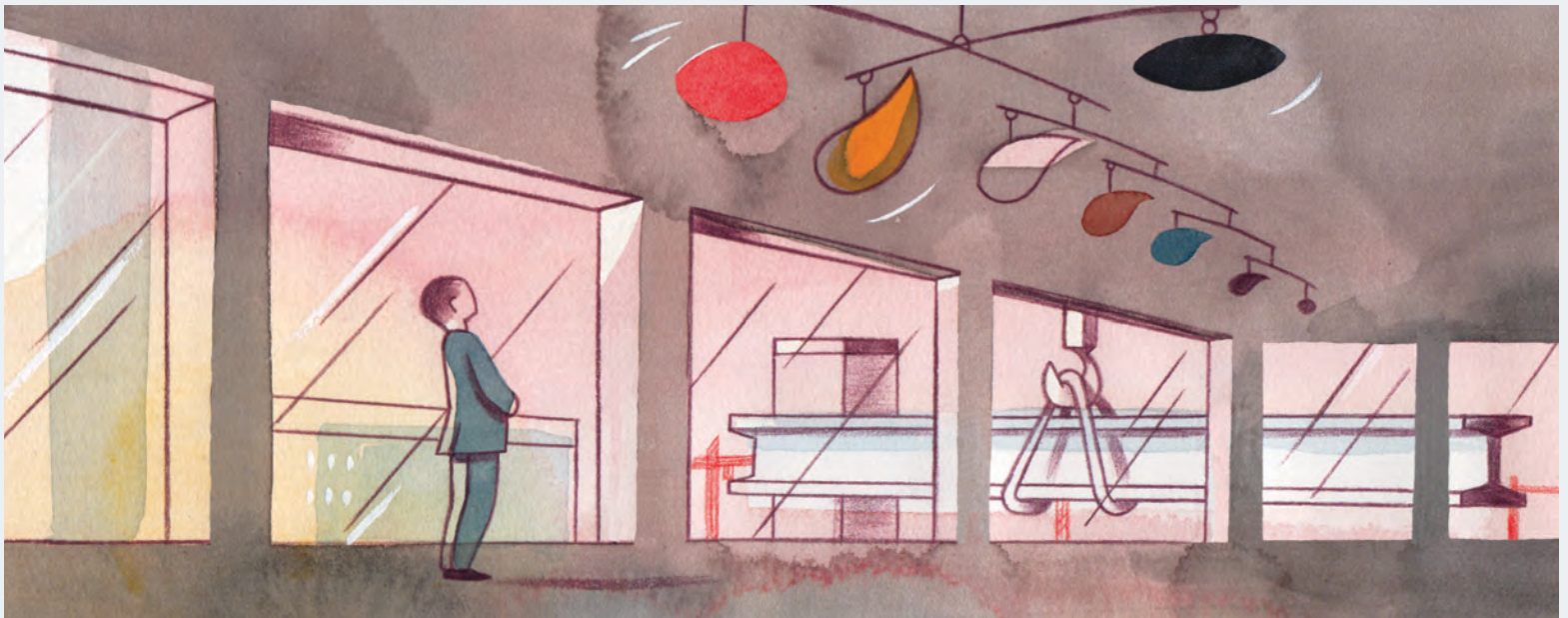

**Are changing** office styles and increased scrutiny of embodied carbon driving the use of ever longer single spans? Typical steel spans in the latest British Council for Offices Guide to Specification now go up to 15m, reflecting this sector's increasing appetite for longer spans and flexibility of space.

Designers are constantly pushing the envelope to achieve longer and longer spans to create column-free space, according to Neil Pennell, chairman of the BCO's technical committee and head of sustainability & engineering at developer Land Securities.

While this has long been the case for financial services, it is becoming increasingly popular in other types of workplace.

'Now the technology and creative sectors are also valuing long span column-free spaces that promote collaborative working and are easy to reconfigure and brand with their own identity,' he says.

'People like to have the freedom to space plan with as much flexibility as possible to

incorporate different workplace settings, with a particular emphasis on collaborative spaces.'

The British Constructional Steelwork Association (BCSA) has also noticed an increased demand for long spans as flexibility becomes a higher priority.

'What your building is used for now might be very different in 10 years time,' says BCSA marketing and technical development manager Chris Dolling. 'Almost every sector can benefit from the greater potential for adaptation that long-spans provide.'

'Where you may have had smaller grids of 6m or 9m in the past, now we're finding that 15-16m spans are a regular thing, particularly with cellular beams, where you can compress your services into the structural zone.'

This trend is not confined to offices. Leisure buildings have always had to prioritise long spans and there are signs that these are becoming increasingly desirable in the education sector too, as clients seek to build

assets rather than future white elephants. In Liverpool, for example, the city council has commissioned four new schools, all designed with long clear spans to allow scope for alternative uses in the event the buildings ever lose their educational function.

BDP's St John Bosco Arts College, for example, was designed like a giant shed with roof trusses spanning 50m and a removable internal configuration.

'The framing solution to this building is fundamental to the longevity and flexibility,' says the project's structural engineer, Danny Sinclair, who is an associate partner at The Alan Johnston Partnership.

He has also seen an increase in longer spans in student housing projects. 'Some of my clients with long term investment in the development will not allow cellular load-bearing construction because it's a short term snapshot of a building use,' he says.

Flexibility was also a driving factor for engineer Peter Brett Associates (PBA) when

the practice planned the steel structure for Oxford University's BioEscalator innovation centre, now under construction, which has been designed with 14m clear spans using 700mm deep cellular beams.

'We did look at internal columns but opted to go with longer spans for future flexibility and to reduce foundation costs,' says PBA equity director Fergal Kelly, who specialises in higher education projects.

He has noticed that exposed steel structures are increasingly acceptable, and that requires more attention to the aesthetics of the steel structure and connections.

Flexibility of space is also likely to rise up the agenda in tandem with the greater focus on embodied carbon as buildings must become more efficient to run.

'We should either be designing for disassembly or for longevity and flexibility so that you can repurpose a building. For this, long spans give more options,' says BCO's Neil Pennell. 'And while it costs more to have longer spans, this is often a premium worth paying to create better quality space.'

In deciding the best structural solution for larger spans, engineers need to juggle weight, fabrication costs and vibration issues as well as achieving the maximum number of lettable floors at the desired floor-to-ceiling height.

'Longer spans need deeper structural

zones, so the further you go with your span, the more space will be taken up out of the total building height by structure – leaving less for usable floors,' says Michael Heywood of Arup, senior engineer of the new Monument Building in the City of London.

'Thus there is often a balance to be struck between flexibility of internal space planning (fewer columns and longer beam spans) versus more lettable floors with shallower structural zones (more columns and shorter beam spans).' In the Monument Building, 12m cellular beams minimise the structural zone.

So at what point do single flat beam spans stop being feasible? According to BCSA's Dolling, trusses generally become economic for spans of more than 25m when the stiffening required for steel beams makes lighter truss constructions more practical.

'It's a balance of materials and manpower costs. The point where beams and trusses cross over tends to be from 20-25m,' he says, adding that the shorter the span, the less cost-effective the truss because of the increased cost of fabrication.

Fergal Kelly of PBA agrees. 'Conventional wisdom is to look at trusses rather than beams when you're going beyond the 15-18m mark for floors and 20m for roofs.'

'In terms of fabrication cost, that tends to work out cheaper,' he says.

Cost comparisons aren't always straightforward, however. As The Alan Johnston Partnership's Sinclair points out, longer spans can lead to reduced foundation numbers, as at St John Bosco school, the savings offsetting the larger cost of the superstructure.

However, deep floor plates with no internal atriums, where some occupants are further from natural daylight, may also have implications for air-conditioning and lighting and so influence whole-life running costs and overall carbon impact. Installation and transportation must also be factored in.

'A 50m steelwork truss can be transported in multiple sections and spliced together on site. Delivering long span members in alternative materials or continuous rolled sections can become a major operation in itself.'

Longer spans can also be an advantage in controlling vibration issues that can occur in common office grids such as 9m x 9m.

'When spans get longer there's enough mass to keep vibration within limits,' Kelly points out. And while there is a cost premium for longer spans, increasingly clients seem willing to pay it.

'The cost of the frame is a pretty small proportion of the final building cost,' says BCSA's Dolling. 'In effect, you're giving your client long-term flexibility forever, for a fairly small extra cost.' ●

## LONG SPAN OPTIONS

**PARALLEL BEAM** Effective for spans of up to around 14m. Consists of floor grids with two layers of fully continuous beams running in orthogonal directions.

**COMPOSITE BEAMS WITH WEB OPENINGS (below)** Suitable for spans of 10-16m with openings to allow services to pass through the beam. Includes cellular beams, formed by splitting two rolled sections longitudinally to form two T sections.



**TAPERED GIRDERS (above)** Suitable for 10-20m spans. The depth of the girder increases mid-span with scope to hang services under the shallower regions.

**STUB GIRDERS** Vierendeel truss with a shallow open section forming the bottom chord, on which sit short lengths of deeper I sections. The top chord is formed by the composite slab. Gives spans of more than 20m.

**HAUNCHED COMPOSITE BEAMS** Haunches at the ends of the beam mean that the rest of the span can be shallower, with services passing underneath. Can span more than 20m.

**COMPOSITE TRUSSES** These use the concrete slab as the upper chord in the final state and can achieve spans of more than 20m. Services can pass through the gaps between the truss members.

**TRUSSES (roofs) AND LATTICE GIRDERS (floors)** Triangular or rectangular assemblies of tension and compression elements formed by bolting or welding standard sections together and with bracing in a W or N form. This system is capable of achieving spans of up to 80m.

**SPACE FRAME** This option requires the assembly of small structural components in tension and compression. These are connected at preformed nodes and by inclined bracing.





JOHN MADDEN

Incisions in the 'giant engine block' of

# Making it big in the City

Architect Make's monolithic new 'groundscraper' for UBS at Broadgate utilises a steel structure to accommodate four huge trading floors

**Words** Pamela Buxton

**5 Broadgate** is a steel building through and through. Not only does the new City of London headquarters for UBS have a main structural frame of steel but, unusually, so do its basements and most of its cores. Moreover, it's clad with 240 tonnes of stainless steel, one of the most extensive applications of such cladding in the UK.

At 65,000m<sup>2</sup>, the project is Make's largest to date. The architect was appointed in 2010 after British Land decided to redevelop its sites at 4 & 6 Broadgate to provide the larger

premises it needed to bring UBS' 6000 staff together in one office for the first time. UBS preferred this option, which crucially provided four trading floors of 6000m<sup>2</sup> each for up to 750 traders per floor, to a refurbishment of its old Broadgate premises or relocation to Canary Wharf.

A 120m x 60m 'groundscraper' building was designed to accommodate the extensive trading floors. Make describes its concept for the 13-storey building as resembling a perfectly machined, solid metal object akin to a

giant engine block, which is cut into to allow light in and views out, particularly on the upper office storeys that aren't constrained by the trading floors. After experimenting with other approaches, the architect decided on a single expression with no movement joints, allowing the trading floors on levels 2-5 and the more conventional office space to be read as one. Trading support is on level 6 with client and meeting levels on floors 7 and 8 and offices on floors 9 to 12.

'We set out to achieve an expression of



**Right** Stainless steel cladding was chosen over aluminium to achieve panels that were as flat as possible.

BURO HAPPOLD ©

quality and timelessness, which UBS could relate to in their brand,' says Make architect Matthew Bugg. 'We wanted to unify the architectural expression as a single form to reflect the single office function.'

The need to accommodate such large trading floors led to the choice of steel as the framing structure. Space planning requirements for 750 traders per 6000m<sup>2</sup> trading floor drove the design of the 13.5m x 12m structural grid and in particular the position of the four stability cores along each edge.

'It was critical to maximise the inside space so the cores were pushed to the periphery,' says Bugg, adding that the lack of a central core meant that concrete was quickly discounted as a framing option.

'We would have needed to use post-tensioned concrete, which would've been very complicated and not cost-effective,' he says.

The core arrangement meant that the cores on the north and south of the building

provided the restraint while allowing the building structure to 'breathe' horizontally. Because the grid had to be maintained in the two-level basement zone, it was decided to use steel rather than the customary concrete.

The frame uses a primary beam arrangement of pairs of floor beams (see top right) either side of supporting fabricated H section columns, laid out on a 12m x 13.5m structural grid. It creates 5m floor-to-floor dimensions, accommodates a chilled beam ceiling system and yields 3.5m floor-to-ceiling heights – rather more than the 2.8m of typical offices.

A number of transfer structures are incorporated, most significantly on the north-west corner (see bottom right) where the presence of a sewer beneath the footprint of the building prevented any foundations in that area.

Everything was detailed to take account of progressive collapse issues, which also influenced the use of steel rather than concrete for most of the cores. Buro Happold was

heavily involved with steelwork contractor Severfield for the connection design, defining and prescribing the position and spacing of the bolts and the thicknesses of the end plates.

'We were very prescriptive on the steel to steel connections,' says Buro Happold director Franck Robert, adding that this ensured the connections would be ductile enough and behave the way they wanted them to in the event of one of the unprotected columns being taken out accidentally. 'We provided the client with a resilient building cost-effectively.'

Steel sizes were driven by stringent vibration considerations. In total Severfield fabricated, supplied and erected 13,000 tonnes of structural steelwork, which received 75 and 120 minute intumescent fire protection applied offsite. The steelwork included 270 flights of staircases and 90,000m<sup>2</sup> of metal floor decking.

Make favoured a metal-clad building from the outset. Large-scale cladding in 6m x 1.5m



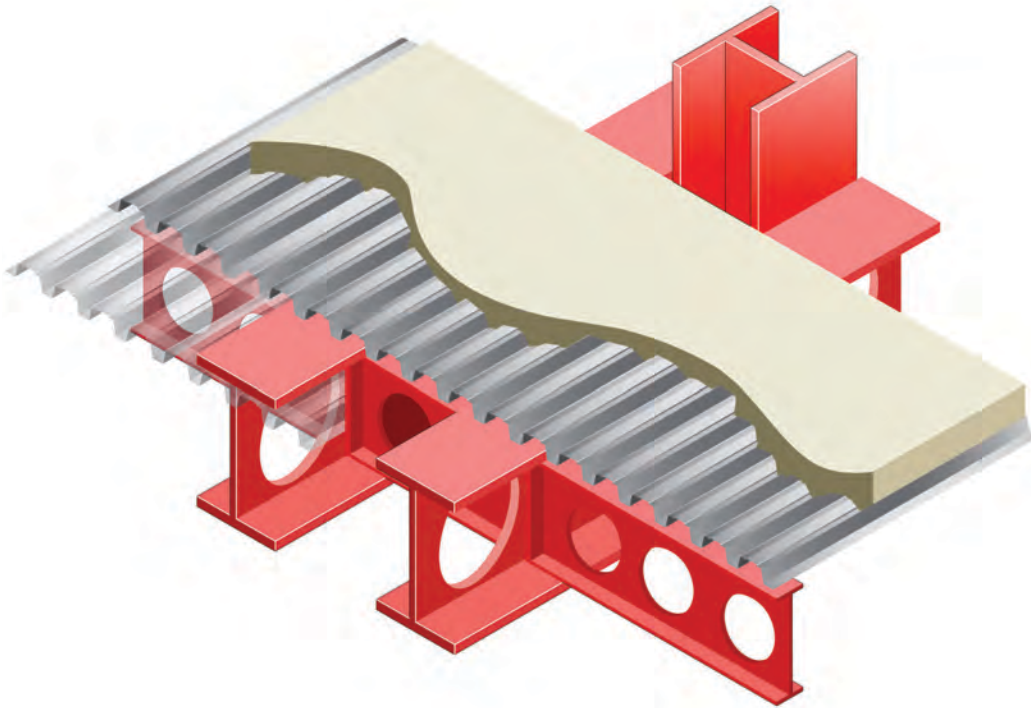

### DOUBLE PRIMARY BEAMS

5 Broadgate is Make's first steel-framed project with double primary beams. These are spaced 1m apart and span 12m. Secondary beams at 3m centres span 12.5m between these. The pairs of primary beams run either side of the supporting steel columns. They are connected to these via steel stubs that are factory-welded to the side of the columns. The primary beams are bolted to the stubs on site. The dual arrangement enables moment continuity over the column locations and so creates a more structurally efficient system, enabling the engineers to reduce the span of the secondary beam. This cost-neutral solution resulted in a 12% reduction in weight and a 9% reduction in carbon impact for the steel floor structure. Both the primary and secondary beams are typically 650mm deep, with 400mm diameter circular holes and 1500mm wide x 400mm deep slots through the web to allow for flexible integration of services. This system supports a 150mm thick composite floor slab.

panels and the lack of mullions and joints help to break down the mass of the building, according to architect James Goodfellow. Stainless steel was chosen over aluminium because it suited the aspiration for panels to be as flat as possible. These are 380mm deep and after a linear pattern had been pressed into the metal they were bead-blasted to give a less glossy finish. The building is 65% clad, with windows positioned to maximise light but minimise solar gain.

A BREEAM 'Excellent' rating is anticipated for 5 Broadgate with 65% lower carbon emissions than the two buildings that preceded it on this site. The facade and structure are calculated as accounting for 57% of the construction carbon footprint and 28% of the whole life carbon footprint, while building operation accounts for 51% of the latter.

Fit-out by interior architect TP Bennetts is under way and UBS is expected to take occupation towards the end of the year. ●



### ROOF TRUSS

A storey-height, 19.5m truss was installed at lower roof level to support the 6m x 9m hung north-west corner of the building. Installation was tricky because the 40 tonne truss had to be positioned in exactly the right place at the corner before the addition of the extra weight of the cladding. This precision was achieved by weighing down the facade with water to mimic the effect of the cladding weight, and draining off water as the cladding was installed.

#### Credits

**Occupier:** UBS  
**Developer:** British Land and GIC  
**Architect:** Make  
**Structural engineer:** Buro Happold  
**Contractor:** Mace  
**Steelwork contractor:** Severfield



RICHARD BICKFORD

## Brunel's last hurrah



Chris Wise of Expedition Engineering on the Royal Albert Bridge at Saltash

**Isambard Kingdom Brunel's** bridge at Saltash was one of his last projects, connecting England with the Cornish peninsula over the River Tamar. It's a total one-off – there's never been another quite like it.

I first went down to visit it with architect Alex de Rijke of de Rijke Marsh Morgan, whose mother lived in Saltash. I found it quite inspirational.

It looks beautiful with these two great arches spanning 140m each. The design took a belt and braces approach – there are arches and suspension when you really only need one of them. And they braced it together as well, with more bracing added over the years in a sort of ongoing experiment in how to carry trains.

At the time, people didn't know much

about how trains affected the structure, which perhaps explains the enterprising design. They built it on the bank, propped it up and loaded it up with 1000 tonnes of ballast to simulate the weight of a train and measure how far it sagged.

When the trusses were floated out into the centre of the river before being jacked up into position, Brunel personally presided over the proceedings and stood there signalling with semaphore flags. Twenty thousand people bought tickets to watch.

He was too ill to attend the opening in May 1859 but did cross it in an open wagon before his death in September. His railway still goes across it. For me, the bridge goes way beyond a piece of engineering. It has become part of the landscape. ●



NIL FANION

**Above** Brunel's design took a belt and braces approach – arches and suspension.

**Top** The two great arches span 140m each across the River Tamar.