

STEEL BUILDINGS IN EUROPE

Multi-Storey Steel Buildings

Part 2: Concept Design

Multi-Storey Steel Buildings

Part 2: Concept Design

FOREWORD

This publication is a second part of a design guide, *Multi-Storey Steel Buildings*.

The 10 parts in the *Multi-Storey Steel Buildings* guide are:

- Part 1: Architect's guide
- Part 2: Concept design
- Part 3: Actions
- Part 4: Detailed design
- Part 5: Joint design
- Part 6: Fire Engineering
- Part 7: Model construction specification
- Part 8: Description of member resistance calculator
- Part 9: Description of simple connection resistance calculator
- Part 10: Guidance to developers of software for the design of composite beams

Multi-Storey Steel Buildings is one of two design guides. The second design guide is *Single-Storey Steel Buildings*.

The two design guides have been produced in the framework of the European project "Facilitating the market development for sections in industrial halls and low rise buildings (SECHALO) RFS2-CT-2008-0030".

The design guides have been prepared under the direction of Arcelor Mittal, Peiner Träger and Corus. The technical content has been prepared by CTICM and SCI, collaborating as the Steel Alliance.

Contents

	Page No
FOREWORD	iii
SUMMARY	vi
1 INTRODUCTION: STRUCTURAL DESIGN IN OVERALL BUILDING DESIGN	1
1.1 Hierarchy of design decisions	2
1.2 Client requirements	3
1.3 Economics	5
1.4 Construction programme	6
1.5 Sustainability	7
2 BENEFITS OF STEEL CONSTRUCTION	11
2.1 Speed of construction	11
2.2 Construction process	12
2.3 Long spans and service integration	13
2.4 Lightweight structures and resource efficiency	14
2.5 Benefits of adaptability	15
3 CASE STUDIES ON MULTI-STOREY STEEL BUILDINGS	16
3.1 Office Building, Bishops Square, London	16
3.2 Le Seguana, Paris	18
3.3 Luxembourg Chamber of Commerce	19
3.4 Kings Place, Kings Cross, London	20
3.5 Kone Headquarters, Helsinki	21
3.6 AM Steel Centre, Liege	22
4 ANATOMY OF BUILDING DESIGN	24
4.1 Floor grids	24
4.2 Dimensional coordination	25
4.3 Structural options for stability	27
4.4 Columns	30
4.5 Structural options for floor systems	31
4.6 Factors influencing structural arrangements	35
4.7 Structure – service integration	37
5 FLOOR SYSTEMS	40
5.1 Composite construction	40
5.2 Composite beams and composite slabs with steel decking	40
5.3 Long-span composite beams with web openings	45
5.4 Cellular composite beams with composite slab and steel decking	47
5.5 Composite beams with precast concrete units	50
5.6 Non-composite beams with precast units	53
5.7 Integrated beams with precast concrete units	55
5.8 Asymmetric beams and deep decking	59
5.9 Beam connections	60
6 OTHER DESIGN ISSUES	63
6.1 Accidental Actions	63
6.2 Floor dynamics	65
6.3 Corrosion protection	67
6.4 Temperature effects	67
6.5 Fire safety	67
6.6 Acoustic performance	68
6.7 Energy efficiency	70
6.8 Cladding	70
REFERENCES	75

SUMMARY

This publication presents information necessary to assist in the choice and use of steel structures at the concept design stage of modern multi-storey buildings. The primary sector of interest is commercial buildings, but the same information may also be used in other sectors. The information is presented in terms of the design strategy, anatomy of building design and structural systems that are relevant to the multi-storey buildings. This publication on the concept design of multi-storey frames complements other parts of the guide.

The use of long span composite construction is considered to be a very important step towards the greater use of steel in multi-storey buildings, and these forms of construction are emphasised in this publication. Cellular beams and perforated steel sections are promoted, as integrated solutions providing long spans without increasing overall floor depth. Long spans provide column-free adaptable space with fewer foundations. Integrated beams are also beneficial where the beam depth is minimised, such as in renovation applications. Other forms of floor construction, such as precast concrete units, are also covered.

Tables are provided for preliminary design of the various structural systems, with typical layouts, sizes and guidance on the key design issues.

1 INTRODUCTION: STRUCTURAL DESIGN IN OVERALL BUILDING DESIGN

In multi-storey buildings, the design of the primary structure is strongly influenced by many issues, as defined below:

- The need to provide clear floor spans for more usable space
- The choice of cladding system
- Planning requirements, which may limit the building height and the maximum floor-to-floor zone
- The services strategy and effective integration of building services
- Site conditions, which dictate the foundation system and location of foundations
- Craneage limitations and storage space for materials and components
- Speed of construction, which may influence the number of components that are used and the installation process.

Studies show that the cost of the building structure is generally only 10% of the total building cost – and the influence of the choice of structure on the foundations, services and cladding are often more significant^[1]. In reality, building design is a synthesis of architectural, structural, services, logistics and buildability issues. Steel frames are ideally suited for modern multi-storey commercial buildings such as that shown in Figure 1.1.



Figure 1.1 Modern commercial building in steel

1.1 Hierarchy of design decisions

The development of any proposal for a construction project requires a complex series of design decisions that are inter-related. The process should begin with a clear understanding of the client requirements and of local conditions or regulations. Despite the complexity, it is possible to identify a hierarchy of design decisions, as shown in Figure 1.2.

Firstly, planning requirements are likely to define the overall building form, which will also include aspects such as natural light, ventilation and services. The principal design choices that need to be made in close consultation with the client are:

- The depth of the floor zone and the overall structure/service interaction strategy
- The need for special structural arrangements in public spaces or circulation areas
- The provision of some tolerance between structure and services, to permit future adaptability
- The benefit of using longer span structure, at negligible extra cost, in order to enhance flexibility of layout.

Based on the design brief, a concept design is then prepared and is reviewed by the design team and client. It is this early interactive stage where the important decisions are made that influence the cost and value of the final project. Close involvement with the client is essential.

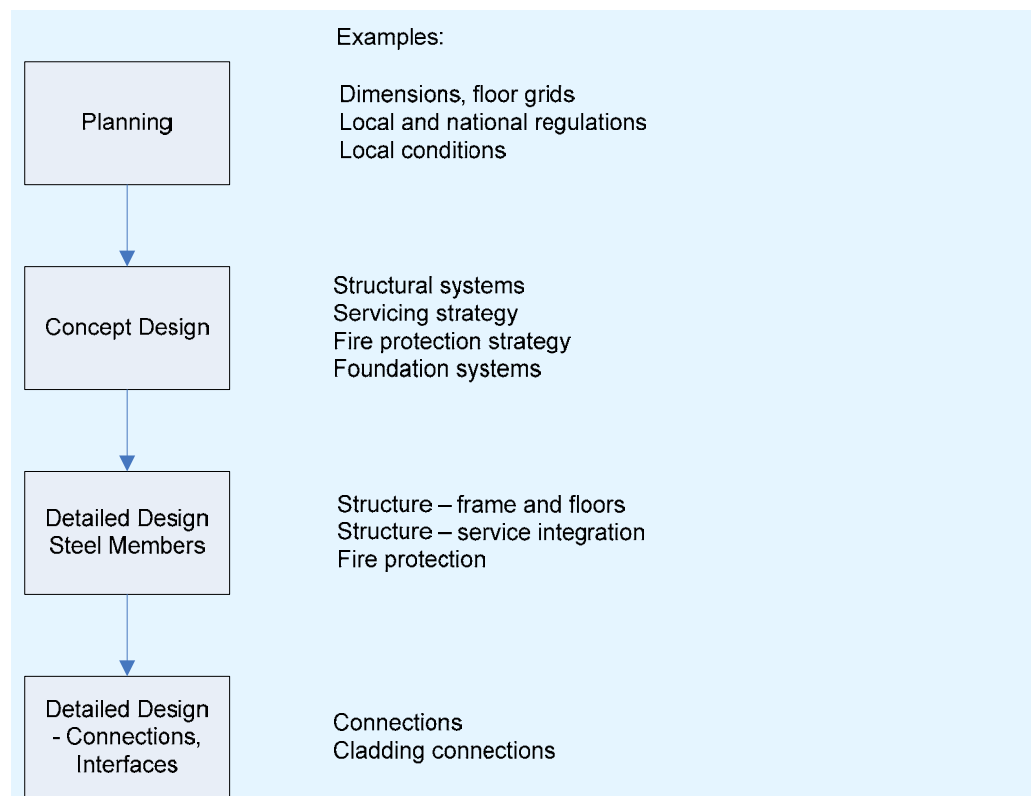

Figure 1.2 Hierarchy of design decisions

Once the concept design is agreed, the detailed design of the building and its components is usually undertaken with less direct interaction with the client. Connections and interfaces between the components are often detailed by the fabricator or specialist designer but the lead architect should have an understanding of the form of these details.

1.2 Client requirements

1.2.1 Spatial Requirements

Client requirements may be defined firstly by general physical aspects of the building, e.g. the number of occupants and their range of functions, planning modules or floor-to-floor zones. Minimum floor loadings and fire resistance periods are defined in national regulations, but the client may wish to specify higher requirements.

Examples of general client requirements are:

Occupation density	1 person per 10 m to 15 m ²
Useable floor area : Total area	80 to 90% typically
Floor-to-floor zone	3,6 m to 4,2 m
Floor-to-ceiling zone	2,7 m to 3 m typically
Planning module	1,2 m to 1,5 m
Imposed loading	2,5 to 7,5 kN/m ²
Fire resistance	R60 to R120

The floor-to-floor zone is a key parameter, which is influenced by planning requirements on overall building height, natural light, cladding cost and other aspects.

1.2.2 Service requirement

Other client requirements may be defined under the heading of ‘servicing’, which includes Information Technology and other communication issues in addition to ventilation, lighting and other servicing requirements. In most inner city projects, air conditioning or comfort cooling is essential, because noise limits the use of natural ventilation. In sub-urban or more rural sites, natural ventilation may be preferred.

Design requirements for building services are usually determined by regulations in the country where the structure is to be constructed and are a function of the external and internal environments.

Typical examples of client requirements for design of the primary building services are:

Fresh air supply	8-12 litres/sec per person
Internal temperatures	22°C ± 2°C
Cooling load	40-70 W/m ²
Thermal insulation (walls)	$U < 0,35 \text{ W/m}^2\text{°K}$

Data communications are normally placed under a raised access floor to facilitate access by the user and future modifications. Other services are generally supported under the floor, above a ceiling. The services can become highly congested and an integrated solution, such as that shown in Figure 1.3 can be advantageous in minimising the overall depth required to accommodate both structure and services.



Figure 1.3 Services integrated with a cellular floor beam

1.2.3 Floor loading

Floor loadings are presented in national Regulations or in EN 1991-1-1, and minimum values can be increased by client requirements. Floor loading has three basic components:

- Imposed loading, including partitions
- Ceiling and services, and a raised floor
- Self weight of the structure.

Imposed loading is dependant on the use of the building and design loads range from 2,0 to 7,5 kN/m², as illustrated in Table 1.1, which has been extracted from Table 6.2 of EN 1991-1-1. Imposed loads on floors should be taken from EN 1991-1-1 Tables 6.1 and 6.2. §6.3.1.2(8) provides an allowance for movable partitions ranging between 0,5 kN/m² and 1,2 kN/m². A further 0,7 kN/m² is generally allowed for ceiling, services and a raised floor.

For perimeter beams, it is necessary to include the loading from façade walls and internal finishes which can range from 3 to 5 kN/m for lightweight cladding to 8 to 10 kN/m for brickwork and 10 to 15 kN/m for precast concrete panels.

The self weight of a typical composite floor is 2,8 to 3,5 kN/m², which is only about 50 % of that of a 200 mm deep reinforced concrete flat slab. The self weight of a precast hollow core concrete slab and concrete topping is typically 3,5 to 6,5 kNm² for a similar span.

Other typical weights are illustrated in Table 1.2.

Table 1.1 Typical imposed loads for offices (kN/m²)

En 1991-1-1 Category	Application	Imposed Loading	Partitions	Ceiling, Services, etc.
B	Offices - general	2,0 – 3,0	0,5 – 1,2	0,7
C1	Areas with tables	2,0 – 3,0	0,5 – 1,2	0,7
C2	Areas with fixed seats	3,0 – 4,0	0,5 – 1,2	0,7
C3	Areas open to crowds	3,0 – 5,0		
C5	Areas open to large crowds	5,0 – 7,5		

Table 1.2 Typical weights for building elements

Element	Typical weight
Precast units (Spanning 6 m, designed for a 5 kN/m ² imposed load)	3,5 to 4,5 kN/m ²
Composite slab (Normal weight concrete, 140 mm thick)	2,8 to 3,5 kN/m ²
Composite slab (Light weight concrete, 130 mm thick)	2,1 to 2,5 kN/m ²
Services (lighting)	0,25 kN/m ²
Ceilings	0,1 kN/m ²
Steelwork (low rise 2 to 6 storeys)	35 to 50 kg/m ²
Steelwork (medium rise 7 to 12 storeys)	40 to 70 kg/m ²

1.2.4 External Loading

Roofs are subject to imposed loads, to be taken from EN1991-1-1, typically 0,4 or 0,6 kN/m².

Roofs are also subject to snow loads, which should be determined from EN 1991-1-3.

Wind loads should be calculated from EN 1991-1-4.

The determination of these loads is covered by other documents in this series^[2].

1.3 Economics

1.3.1 Cost of construction

A breakdown of construction costs for a typical office building^[1] is approximately as below:

Foundations	5-15%
Super structure and floors	10-15%
Cladding and roofing	15-25%
Services (mechanical and electrical)	15-25%
Services (sanitation and other services)	5-10%
Finishes, partitioning and fitments	10-20%

Preliminaries (site management) 10-15%

Preliminaries represent the costs of the site management and control facilities, including cranes, storage and equipment. Site preliminaries can vary with the scale of the project and a figure of 15% of the total cost is often allowed for steel intensive construction reducing to 12% for higher levels of offsite prefabrication. The superstructure or framework cost is rarely more than 10% of the total, but it has an important effect on other costs. For example, a reduction of 100 mm in the ceiling floor zone can lead to a 2,5% saving in cladding cost (equivalent to 0,5% saving in overall building cost).

1.3.2 Benefits of steel construction

Steel construction offers many benefits to the client/user in operation including:

- Column-free spans, permitting flexibility in use
- Ease of extension and adaptation in the future, including needs for re-servicing
- Variety of cladding and roofing systems
- Long design life and ease of maintenance
- Energy efficient design.

These benefits of steel construction are explored in Section 2.

1.3.3 Cost of ownership / occupancy

It is estimated that the total cost of running a building during a 60 year design life may be 3 to 5 times the cost of initial construction. Major components in the longer term costs include:

- Direct running costs of heat, lighting, air conditioning
- Refurbishing the interior, minor redecoration every 3-5 years, major refitting every 10-20 years
- Replacing the services, approximately every 15-20 years
- Possibly re-cladding the building after 25-30 years.

The European Directive on Energy Saving in Buildings now requires that office buildings carry an 'energy passport' which defines the energy use and energy saving measures. Many modern buildings are designed with energy saving measures in mind, including double skin facades, thermal capacity and chimneys for natural ventilation and photovoltaics in roofing.

1.4 Construction programme

A typical construction programme for a medium-sized office building is shown in Figure 1.4. One of the advantages of steel construction is that the initial period of site preparation and foundation construction permits sufficient time for off-site fabrication of the steel structure into a 'kit of parts'. This is known as 'Fast track' construction.

The installation of the primary structure and floors takes approximately 20-25% of the total construction period but its completion permits an early start on cladding and servicing. It is for these reasons that steel construction leads to considerable advantage in terms of speed of construction, as it is a prefabricated and essentially 'dry' form of construction.

In a typical construction project, savings in construction period using steel construction compared to other materials can range from 5% to 15% depending on the level of prefabrication that is used. The main programme benefit relative to concrete construction is the creation of a water-tight building envelope early in the construction process. Financial benefits from faster construction are:

- Savings in site preliminaries
- Site productivity gains for the remainder of the construction
- Reduced interest payments
- Earlier income from the new facility.

Typical time-related cost savings are 2% to 4% of the total costs i.e. a significant proportion of the superstructure cost. Furthermore, in renovation projects or major building extensions, speed of construction and reduced disruption to the occupants or adjacent buildings can be even more important.

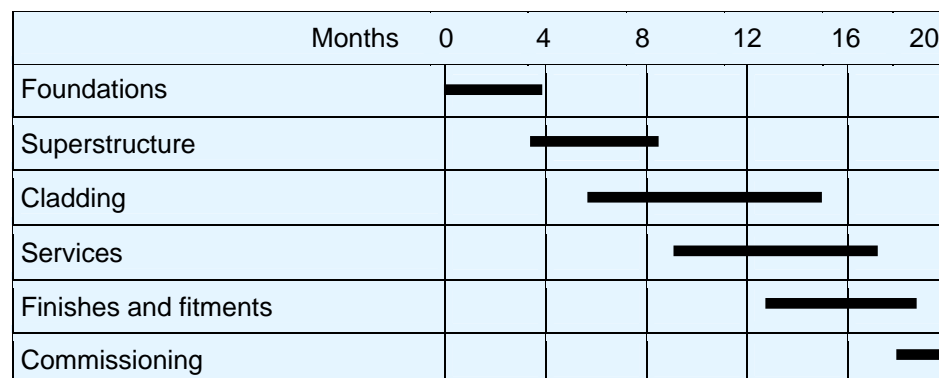

Figure 1.4 Construction programme of a typical 4 to 6-storey commercial building in steel

1.5 Sustainability

Sustainable construction must address three goals:

- Environmental criteria
- Economic criteria
- Social criteria.

These three criteria are met by construction in steel:

Environmental criteria

Steel is one of the most recovered and recycled materials. Some 84% is recycled with no loss of strength or quality, and 10% reused. Before demolishing a structure, extending a building's life is generally more beneficial. This is facilitated by steel construction, since large column-free

spaces give flexibility for change in use. Advances in the manufacturing of raw materials means that less water and energy is used in production, and allows for significant reductions in noise, particle and CO₂ emissions.

Economic criteria

Steel construction brings together the various elements of a structure in an integrated design. The materials are manufactured, fabricated and constructed using efficient production processes. The use of material is highly optimised and waste virtually eliminated. The structures themselves are used for all aspects of modern life, including logistics, retail, commercial, and manufacturing, providing the infrastructure on which society depends. Steel construction provides low investment costs, optimum operational costs and outstanding flexibility of building use, with high quality, functionality, aesthetics and fast construction times.

Social criteria

The high proportion of offsite fabrication in steel buildings means that working conditions are safer, controlled and protected from the weather. A fixed location for employees helps to develop communities, family life and the skills. Steel releases no harmful substances into the environment, and steel buildings provide a robust, safe solution.

Multi-storey buildings

The design of multi-storey buildings is increasingly dependent on aspects of sustainability, defined by criteria such as:

- Efficient use of materials and responsible sourcing of materials
- Elimination of waste in manufacturing and in construction processes
- Energy efficiency in building operation, including improved air-tightness
- Measures to reduce water consumption
- Improvement in indoor comfort
- Overall management and planning criteria, such as public transport connections, aesthetics or preservation of ecological value.

Steel framed buildings can be designed to satisfy all these criteria. Some of the recognised sustainability benefits of steel are:

- Steel structures are robust, with a long life. Properly detailed and maintained, steel structures can be used indefinitely
- Approximately 10% of steel sections are re-used^[3]
- 95% of structural steel sections are recycled
- Steel products can potentially be dismantled and reused, particularly modular components or steel frames
- Steel structures are lightweight for use on poor ground or over tunnels
- Steel is manufactured efficiently in factory controlled processes
- All waste is recycled in manufacture and no steel waste is produced on site

Part 2: Concept Design

- Construction in steel maximises the opportunity and ease of extending buildings and change of use
- High levels of thermal insulation can be provided in the building envelope
- Prefabricated construction systems are rapidly installed and are much safer in terms of the construction processes
- Steel construction is safe to install, and safety features can be introduced into the steel design, such as pre-attached safety barriers, as shown in Figure 1.5.

Different sustainability assessment measures exist in various European countries^[4]. National building regulations present minimum levels of overall energy performance which must be satisfied. Many multi-storey buildings are designed with solar shading and active energy creation technologies, such as Photovoltaics (PVs), as shown in Figure 1.6.

Utilisation of the thermal capacity of the building structure can be achieved using composite slabs, and research has shown that a slab depth of only 50 mm to 75 mm is needed to provide adequate fabric energy storage^[5].



Figure 1.5 Safety barriers pre-attached to the perimeter steelwork



Figure 1.6 'Green' roof and PV panels attached to a city centre office building

2 BENEFITS OF STEEL CONSTRUCTION

In the multi-storey building sector, the benefits of steel construction are largely related to the 'fast track' nature of the construction process, which leads to a wide range of financial and process benefits. Many innovations associated with the construction process have further improved these inherent benefits and have increased efficiency and productivity. This is very important in inner city projects where lack of space for storage of materials and other facilities, limitations on deliveries and logistics, and planning constraints, mean that a higher proportion of work should be done in the factory and less on site.

The benefits of steel in multi-storey construction arise mainly from its prefabricated nature, its lightweight and the ability to phase the various activities in series rather than in parallel. These benefits are explored in the following sections.

2.1 Speed of construction

Speed of construction is the most important benefit offered by steel construction, which leads to financial, management and other logistical benefits, many of which can be experienced in economic as well as sustainability terms. For an eight-storey office building, it is found that steel construction is up to 20% faster than reinforced concrete, but, importantly, the construction of the primary frame and floors is up to 40% faster and allows for early start in building services, installation, cladding and other activities. The fast construction process is based on a synergistic use of steel frames, steel decking and in some cases, concrete or braced steel cores, as illustrated in Figure 2.1.

The financial benefits of speed of construction may be expressed as:

- Early completion, which leads to reduced interest charges on the borrowed capital and to early return in terms of revenue
- Lower cash flow
- Reduced management costs on-site, due primarily to the shorter construction period, but also due to the fewer personnel employed
- Reduced hire costs of site facilities
- Greater certainty and less risk in the construction process.



Figure 2.1 Rapid installation of steelwork and steel decking speeds up the construction process

2.2 Construction process

Speed of construction is achieved by 'just in time' delivery of components and by rapid assembly for the steel framework. It is estimated that a single tower crane can install up to 20 steel elements per day, which corresponds to a floor area of approximately 300 m².

Secondary benefits in steel construction arise from:

- Placing of steel decking, in 'bundles' on the beams and installation of decking at a rate of up to 500 m² per day
- Avoidance of temporary propping by using steel decking spans of 3 m to 4 m for profiles of 50 mm to 80 mm depth
- Fire protection by intumescent coating that is applied in the factory and, therefore, eliminates the time required for this process on-site
- Opportunities for reduction in the amount of fire protection by use of fire engineering analysis
- Use of mobile installation platforms improve construction safety and speed up the installation process, as shown in Figure 2.2
- Prefabricated stairs that are installed as part of the steel construction package
- Safety barriers can be attached to the perimeter steel beams, see Figure 1.5
- Rapid concrete placement of up to 1000 m² area in one day for a 130 m deep slab

- Light steel infill walls and partitions that are installed rapidly and can be prefabricated
- Modular serviced units that may be installed with the steelwork package.



Figure 2.2 Rapid, safe installation of steelwork and steel decking from a mobile erection platform speeds up the construction process

2.3 Long spans and service integration

The integration of building services within the primary structure can be achieved by two methods:

- Designing the structure to be of minimum construction depth so that services pass beneath
- Designing the structure with periodic openings or zones for integration of services within the structural depth.

Long span construction is attractive because it eliminates the need for internal columns and makes the internal space more adaptable to a range of current and future uses. Spans of 12 m to 18 m are readily achieved by a variety of structural steel technologies.

The minimum structural depth is achieved by use of slim floor or integrated beams which have a maximum span capability of around 9 m. Structural systems which provide for service integration include:

- Cellular beams with regular circular openings, as shown in Figure 1.3
- Rolled or fabricated steel beams with periodic openings, often rectangular in shape, as shown in Figure 2.3
- Trusses or other open shaped members.

For commercial buildings, the floor and service zone is typically 800 mm to 1200 mm. For renovation projects where the original façade is retained, slim floor or integrated beams have proved to be attractive and can achieve an overall floor zone of less than 600 mm.

The economics of long span construction may be summarised as:

- Saving in cladding cost (up to 300 mm per floor)
- Elimination of internal columns and increase in useable area (up to 3% of the plan area)
- Fewer steel elements to install (up to 25% less)
- Columns and façades can be located at the perimeter of the building
- Ease of service integration and future servicing
- Future adaptability of the space and re-use of the building.



Figure 2.3 Rectangular openings in composite beams for service distribution

2.4 Lightweight structures and resource efficiency

Steel construction of all types is lightweight, even when including concrete floors. The self weight of a typical composite floor system is typically only 40% of that of a reinforced concrete flat slab. When the total building weight is considered, a steel framed structure is up to 30% lighter than the equivalent concrete building, which leads to an equivalent saving in foundation costs.

Furthermore, steel construction is the preferred solution for building on:

- Post-industrial or former built-on sites, often with pre-existing foundations
- Building over underground services and tunnels
- Building on railway lines and other 'podium-type' structures.

Steel construction virtually eliminates waste by the nature of its manufacturing process and all steel waste is recycled. Synergistic materials such as plasterboard can also be recycled.

2.5 Benefits of adaptability

General expectations for all multi-storey buildings change substantially during their design lives. A building's occupancy is also likely to change several times during its life. Increasingly, the nature of the occupancy may change; for example in many major European cities, there is a growing trend to convert office buildings into apartments.

In the 1960s and 70s, many buildings were constructed to minimum cost without any allowance for future adaptation. These structures have not proved capable of responding to occupant's changing needs, leading to their early demolition.

Although difficult to quantify at the proposal development stage, there are clear qualitative benefits in specifying a structure that is inherently adaptable to changes in requirements during its design life. Key issues on adaptability are:

- Specifying longer spans, permitting greater flexibility of layout
- Providing space for additional services
- Specifying floor loadings that permit change of occupancy.

3 CASE STUDIES ON MULTI-STOREY STEEL BUILDINGS

The following case studies describe the use of steel in multi-storey buildings, primarily in the commercial building sector, but also in the residential sector, where the same technologies are used.

3.1 Office Building, Bishops Square, London



Figure 3.1 Office building, Bishop's Square, London

The Bishop's Square project near to London's Broadgate area comprises a composite steel structure of 18 m span and only 650 mm depth. There is an almost fully glazed façade and a 'green' roof space on three levels. The completed building is shown in Figure 3.1, and during construction in Figure 3.2.

The 12-storey building of close to 80000 m² floor area comprised approximately 9500 tonnes of steelwork, and was erected in only 30 weeks out of an overall 20 month construction programme. Fire protection, in the form of intumescent coatings, was applied off-site in a single operation by the steelwork contractor, which speeded up the following trades.

The highly glazed façade was designed to satisfy onerous thermal requirements which led to the use of triple glazing with integral louvres. Photovoltaic panels were installed on the roof to provide an energy source for lighting, thereby reducing running costs and CO₂ emissions.

Part 2: Concept Design

The floor-to-floor height was only 3,9 m, which necessitated a beam depth of only 650 mm as part of a 1050 mm overall floor zone. The 9 m span heavily loaded primary beams had large rectangular openings, and were tapered in depth close to the concrete cores to allow for distribution of large ducts.

Secondary beams were designed as fabricated steel sections with a series of 425 mm diameter circular openings for services and two rectangular openings of 425 mm depth \times 750 mm length close to mid-span. An imposed load deflection limit of only 30 mm was specified, which was achieved by beams of 138 kg/m weight with no stiffening.



Figure 3.2 View of long span cellular beams in the Bishop's Square project

3.2 Le Seguana, Paris

Le Seguana is a 25000 m² office development on the banks of the Seine in Paris, shown in Figure 3.3. It consists of column free spaces of 18 m × 36 m and is fully air conditioned. The construction was completed in 22 months to programme and budget, including the erection of 2000 tonnes of structural steelwork in only 12 weeks.



Figure 3.3 Le Seguana buildings, Paris, during construction

Stability for the structure was provided by a combination of steel braced cores and slip-formed concrete cores.

The strategy for air conditioning involved local control for every 12 m² of floor space. This demanded a large number of ducts, which were accommodated within the cellular beams, as illustrated in Figure 3.4.

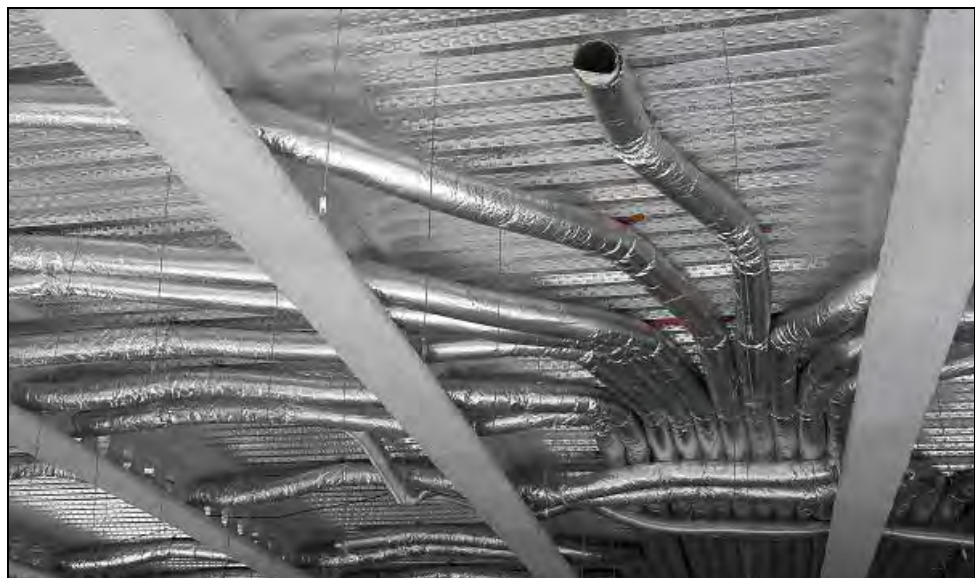

Figure 3.4 Ducts emanating from central plant room – providing locally controlled environment

3.3 Luxembourg Chamber of Commerce



Figure 3.5 Luxembourg Chamber of Commerce

The headquarters of the chamber of commerce of the Grand Duchy of Luxemburg was designed by Vasconi Architects and comprises an existing building and 20000 m² of new office space as shown in Figure 3.5. A conference centre of approximately 8000 m² was provided together with 650 underground parking spaces on four levels. The total building area is 52000 m² including car parking.

The four- and five- storey composite structure consists of hot rolled steel sections and concrete floor slabs with integrated IFB sections (a rolled asymmetric section with a wide bottom flange).

The integrated steel beams are stiffened by the use of a lightweight truss below the beams, leading to a 40% increase in span. Services are passed below the beams and through the truss to minimise the floor depth.

The structure was assessed by a fire engineering analysis, which demonstrated that 60 minutes fire resistance could be achieved without additional fire protection. The IFB beams are partially protected by the concrete slab and support the reduced load in fire despite the loss of the exposed truss.

3.4 Kings Place, Kings Cross, London



Figure 3.6 Kings Place during construction

Kings Place in north London provides seven floors of office space, a 420 seat concert hall, art galleries and restaurants. The basement levels house the auditorium and other recital facilities. It is shown in Figure 3.6 during construction.

The flexible use structure is designed as a steel-composite frame consisting of 12 m span fabricated beams with multiple circular openings and supporting a 130 m deep composite slab. In some areas, the composite floor is supported on a shelf angle. The forms of construction are shown in Figure 3.7.

A novel part of the design was the fire engineering strategy, which demonstrated that the fire resistance of 90 minutes could be achieved by intumescent coatings only on the beams connecting directly to the columns; other beams were unprotected. The columns were protected by two layers of boards. The long span fabricated beams are typically 600 mm deep and consist of multiple 375 mm deep openings. The 130 mm deep composite slab is reinforced according to fire engineering principles which permit development of membrane effects in fire.

The primary and secondary beams connecting to the columns are protected by 1,6 mm thick intumescent coating that was applied off-site to speed up the construction process. The coating was applied in a single layer, which was achieved by designing slightly heavier steel sections to reduce the load ratio in fire conditions. This holistic design approach was justified using a finite element model in which the properties of the steel and concrete were modified for the temperatures in both a standard fire and natural fire concept using the fire load and ventilation conditions established for the building use.

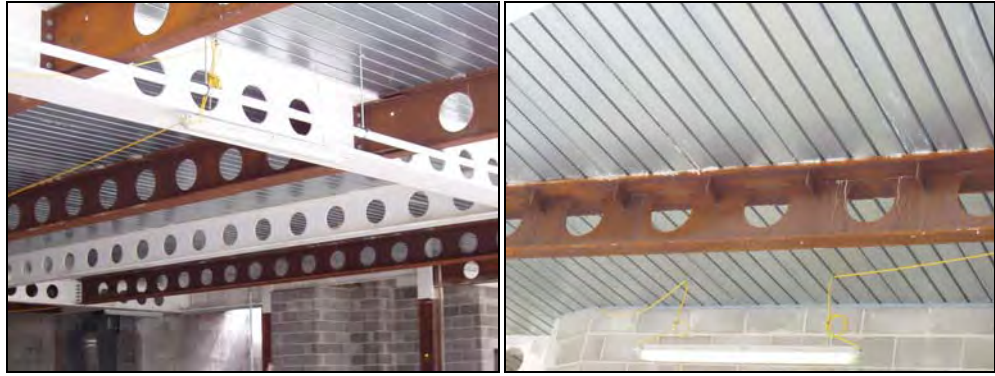

Figure 3.7 Different beam types used in Kings Place

3.5 Kone Headquarters, Helsinki



Figure 3.8 Kone building during construction and completed

The 18-storey Kone headquarters building in Espoo near Helsinki used a composite floor structure and had a fully glazed façade. The total floor area was 9800 m². Stability was provided by a large concrete core located on the south face of the building, as shown in Figure 3.8.

The structure was innovative in its construction because the floor structure was prefabricated as large cassettes and lifted into place, as shown in Figure 3.9. The span of the floor grid was 12,1 m for the primary beams and 8,1 m for the secondary beams. A minimum number of steel columns were used internally.

The east and west facing walls have full height glass panels. The cladding was configured as a double facade to provide shading and also to act as a thermal barrier. The concrete core next to the south facing wall reduced the heat gain on this façade.



Figure 3.9 Prefabricated floor cassette system

3.6 AM Steel Centre, Liege



Figure 3.10 AM building during construction showing the cellular beams

The five-storey Steel Centre in Liege, Belgium is an innovative office building designed to achieve a high level of energy efficiency. It is 16 m × 80 m on plan and consists of an off-centre line of internal columns to create beam spans of 9 m and 7 m. The longer span secondary members are 500 mm deep and are placed at 3 m spacing, which support a composite floor. The secondary members use IPE330/ IPE 300 sections to create cellular beams with regular 400 mm diameter openings. The form of construction is shown in Figure 3.10. The 9 m span primary cellular beams are the same depth and use HEB 320 / HEA 320 sections.

A fire engineering analysis was carried out to demonstrate that the composite beams could be unprotected except for those connected to the columns. The columns are concrete filled circular hollow sections, which are unprotected and achieve the required fire resistance, leading to a considerable reduction in fire protection costs.

The building is supported on piles because of the poor ground conditions in this former industrial area. The low self weight of the structure ($< 350 \text{ kg/m}^2$) and of the curtain walling system was important in minimising the loads on the piles.

4 ANATOMY OF BUILDING DESIGN

The building design is dependent on various parameters:

- Floor grid
- Building height
- Circulation and access space
- Services requirements and service integration.

These aspects are addressed as follows:

4.1 Floor grids

Floor grids define the spacing of the columns in orthogonal directions, which are influenced by:

- The planning grid (normally based on units of 300 mm but more typically multiples of 0,6, 1,2 or 1,5 m)
- The column spacing along the façade, depending on the façade material (typically 5,4 m to 7,5 m)
- The use of the internal space (i.e. for offices or open plan space)
- The requirements for building service distribution (from the building core).

Along the façade line, column spacings are normally defined by the need to provide support to the cladding system (for example, a maximum column spacing of 6 m is normally required for brickwork). This influences the column spacing internally, unless additional columns are used along the façade line.

The span of the beams across the building normally conforms to one of the following column grid arrangement:

- Single internal line of columns, placed offset to the line of a central corridor. This is shown in Figure 4.1
- Pairs of column lines on either side of a corridor
- Column-free internal spans with columns located along the façade line.

For naturally ventilated offices, a building width of 12 m to 15 m is typically used, which can be achieved by two spans of 6 m to 7,5 m. A single span can also be provided with deep (400 mm or more) precast concrete hollow core units spanning the full width of the building. Natural lighting also plays a role in choice of the width of floor plate.

However, in modern buildings, a long span solution provides a considerable enhancement in flexibility of layout. For air-conditioned offices, a clear span of 15 m to 18 m is often used. An example of the column grid for a long span option in a building with a large atrium is shown in Figure 4.2.

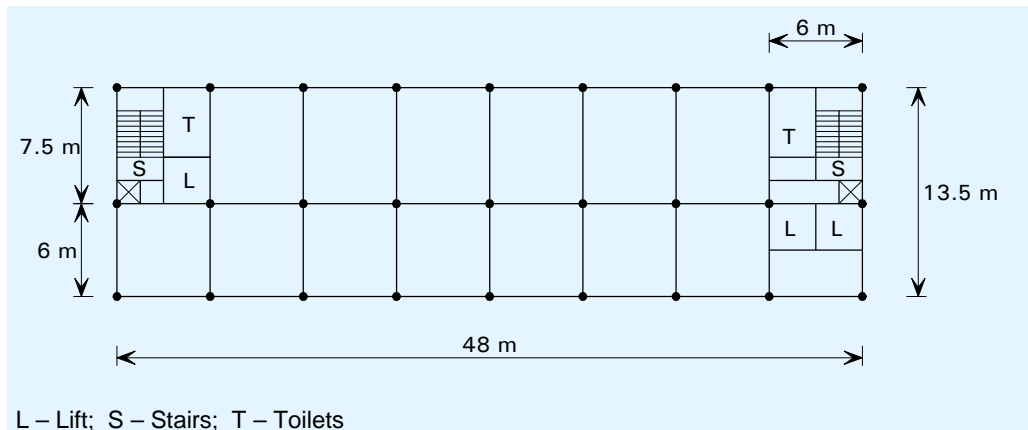

Figure 4.1 Column grid for a naturally ventilated office

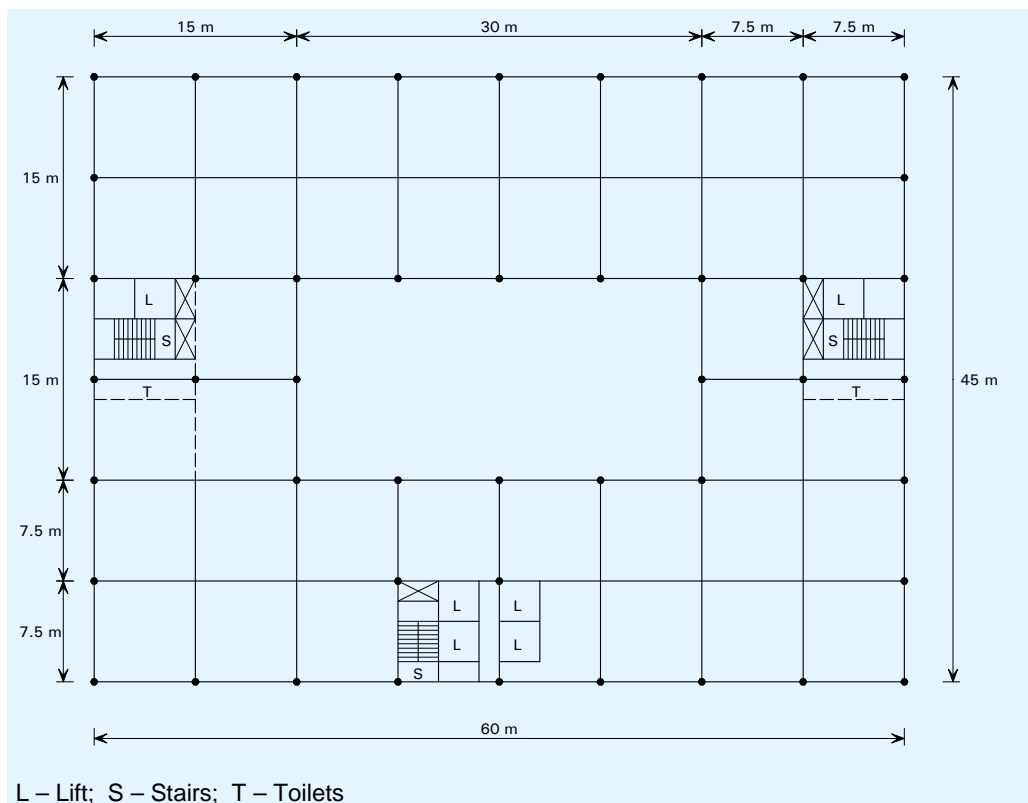

Figure 4.2 Column grid for long span floor in a prestige air conditioned office

4.2 Dimensional coordination

The choice of the basic building shape is usually the Architect's responsibility, constrained by such issues as the site plan, access, building orientation, parking, landscaping and local planning requirements. The following general guidance influences the choice of structure.

- Between sources of natural light there should be 13,5 m and 20 m intervals
- Naturally lit and ventilated zones extend a distance of twice the floor-to-ceiling height from the outer walls – artificial light and ventilation is required in other zones

- Atria improve the efficient use of the building, and reduce the running costs.

4.2.1 Influence of building height

The building height has a strong influence on the:

- Structural system that is adopted
- Foundation system
- Fire resistance requirements and means of escape
- Access (by lifts) and circulation space
- Choice of cladding system
- Speed of construction and site productivity.

For taller buildings, strategically placed concrete or braced steel cores are usually adopted. Ultra tall buildings are influenced strongly by the stabilising system, but are outside the scope of this guidance.

Sizes of lifts and their speed of movement also become important considerations for tall buildings.

Depending on the Regulations for fire safety in the particular country, the use of sprinklers may be required for buildings of more than eight storeys (or approximately 30 m high).

4.2.2 Horizontal coordination

Horizontal coordination is dominated by the need on plan for defined zones for vertical access, safe evacuation in fire, and vertical service distribution. Positioning of service and access cores is influenced by:

- Horizontal distribution systems for mechanical services
- Fire resistance requirements, which may control evacuation routes and compartment sizes
- The need to distribute the stabilizing systems (bracing and cores) effectively throughout the building plan.

Figure 4.1 and Figure 4.2 show typical arrangements that satisfy these criteria.

An atrium may be incorporated to increase lighting to the occupied space and to provide high value circulation areas at ground and intermediate levels. The design requirements for atria are:

- Support to the long span roof of the atrium
- Access routes for general circulation
- Fire safety measures by smoke extraction and safe evacuation routes
- Light levels and servicing to internal offices.

4.2.3 Vertical coordination

The target floor-to-floor height is based on a floor-to-ceiling height of 2,5 m to 2,7 m for speculative offices, or 3 m for more prestige applications, plus the floor depth including services. The following target floor-to-floor depths should be considered at the concept design stage:

Prestige office	4 – 4,2 m
Speculative office	3,6 – 4,0 m
Renovation project	3,5 – 3,9 m

These targets permit a range of structural solutions. If, for planning reasons, it is required to limit the overall building height, this can be achieved by use of slim floor or integrated beam systems. Integrated beam systems are often used in renovation projects where the floor-to-floor height is limited by compatibility with the existing building or façade.

For a 12 m span composite beam, the structural depth is approximately 600 mm. The fire protection thickness (if needed) and an allowance for deflections should also be included (nominally 30 mm).

Where the structural and service zones are separated vertically, the following should be added to the structural depth:

Raised access floor	150 mm to 200 mm
Air conditioning units	400 mm to 500 mm
Ceiling and lighting	120 mm to 250 mm

However, significant reductions in overall depth can be achieved by vertical integration of the structural and service zones. This is particularly effective for longer span construction.

For concept design of orthodox commercial multi-storey steel structures, the following ‘target’ floor depths may be used:

Composite beam construction	800 mm – 1200 mm
Cellular beams (with service integration)	800 mm – 1100 mm
Precast concrete floors (7,5 m span)	1200 mm – 1200 mm
Precast concrete floors (14 m span)	1450 mm – 1450 mm
Slim floor or integrated beams	600 mm – 800 mm

4.3 Structural options for stability

The structural system required for stability is primarily influenced by the building height. For buildings up to eight storeys height, the steel structure may be designed to provide stability, but for taller buildings, concrete or braced steel cores are more efficient structurally. The following structural systems may be considered for stability.

4.3.1 Rigid frames

For buildings up to four storeys high, rigid frames may be used in which the multiple beam to column connections provide bending resistance and stiffness to resist horizontal loads. This is generally only possible where the beams are relatively deep (400 mm to 500 mm) and where the column size is increased to resist the applied moments. Full depth end plate connections generally provide the necessary rigidity.

4.3.2 Braced frames

For buildings up to 12 storeys high, braced steel frames are commonly used in which cross, K or V bracing is used in the walls, generally within a cavity in the façade, or around stairs or other serviced zones. Cross bracing is designed in tension only (the other member being redundant). Cross bracing is often simple flat steel plate, but angle sections and channel sections may also be used.

When bracing is designed to work in compression, hollow sections are often used, although angle sections and channel sections may also be used.

A steel braced frame has the two key advantages:

- Responsibility for temporary stability lies with one organisation
- As soon as the steel bracing is connected (bolted), the structure is stable.

4.3.3 Concrete or steel cores

Concrete cores are the most practical system for buildings of up to 40 storeys high, but the concrete core is generally constructed in advance of the steel framework. In this form of construction, the beams often span directly between the columns on the perimeter of the building and the concrete core. Special structural design considerations are required for:

- The beam connections to the concrete core
- The design of the heavier primary beams at the corner of core
- Fire safety and robustness of the long span construction.

Special attention must be paid to the connections between the steel beams and the concrete cores allowing for adjustment, anticipating that the core may be out of position. The connection itself may not be completed until *in situ* concrete has cured, or until elements have been welded, so attention to temporary stability is important.

A typical layout of beams around a concrete core is shown in Figure 4.3, showing the use of heavier beams at the corner of the core. A double beam may be required to minimise the structural depth at the corner of the cores.

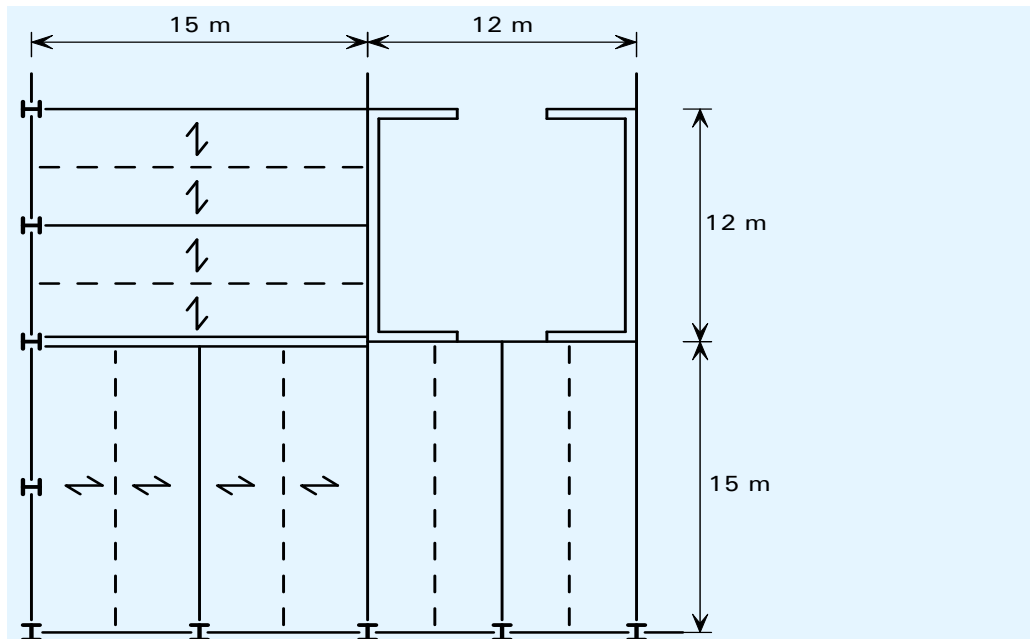

Figure 4.3 Typical beam layout around a concrete core

Steel plated cores may be used as an economic alternative where speed of construction is critical. Double skin cores can be installed with the rest of the steelwork package and the concreting operation can be carried out later. This form of construction is shown in Figure 4.4.



Figure 4.4 Steel composite core speeds up the construction process

4.4 Columns

Columns in multi-storey steel frames are generally H sections, predominantly carrying axial load. When the stability of the structure is provided by cores, or discreet vertical bracing, the beams are generally designed as simply supported. The generally accepted design model is that nominally pinned connections produce nominal moments in the column, calculated by assuming that the beam reaction is 100 mm from the face of the column. If the reactions on the opposite side of the column are equal, there is no net moment. Columns on the perimeter of the structure will have an applied moment, due to the connection being on one side only. The design of columns is covered in detail in *Multi-storey steel buildings. Part 4: Detailed design*^[6].

For preliminary design, it is appropriate to base the choice of column section on axial load alone, but ensure that the column is only working at 90% of its capacity, to allow for the subsequent inclusion of the nominal moments.

Typical column sizes are given in Table 4.1.

Table 4.1 Typical column sizes (for medium span composite floors)

Number of floors supported by column section	typical column size (h)
1	150
2 – 4	200
3 – 8	250
5 – 12	300
10 – 40	350

Although small column sections may be preferred for architectural reasons, the practical issues of connections to the floor beams should be considered. It can be difficult and costly to provide connection into the minor axis of a very small column section.

For ease of construction, columns are usually erected in two, or sometimes three-storey sections (i.e. approximately 8 m to 12 m in length). Column sections are joined with splices, typically 300 mm to 600 mm above the floor level.

It is common to vary the column size within the height of the building, to make efficient use of the steelwork. Although it may be convenient to align the columns on a single centroidal axis, it may be preferable to maintain the same external face, so that all edge details, and supports for cladding, are similar. The floor beams will be slightly different lengths, and the additional moment induced by offsetting the upper column section will need to be accounted for in design.

Typical splice details are shown in Figure 4.5, when a change in section has been accommodated by a division plate between the sections.

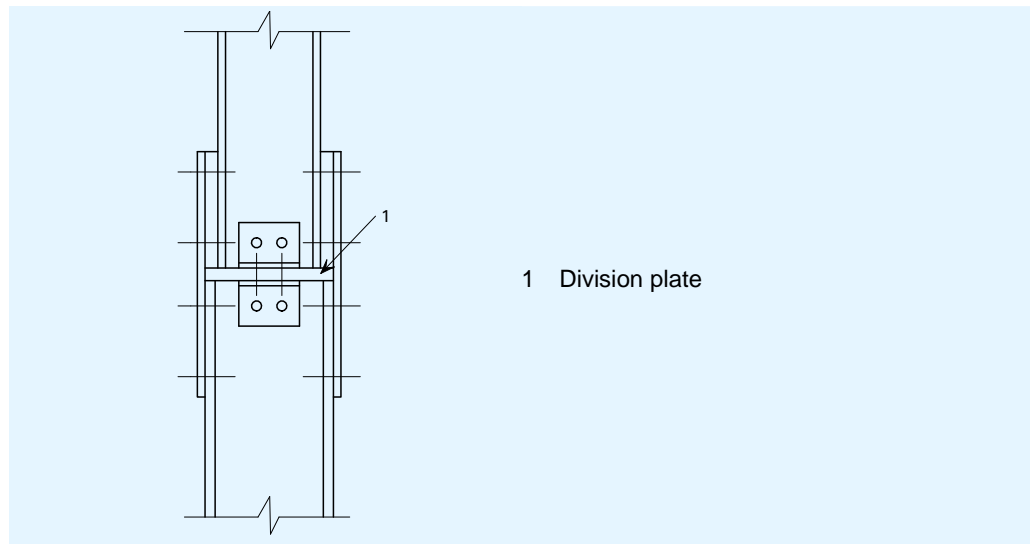

Figure 4.5 Typical splice details with bearing plate

If there are restrictions on space, it is possible to use countersunk bolts in the plates, or if the column sections have the same internal profile, to use internal cover plates and countersunk bolts, as shown in Figure 4.6.

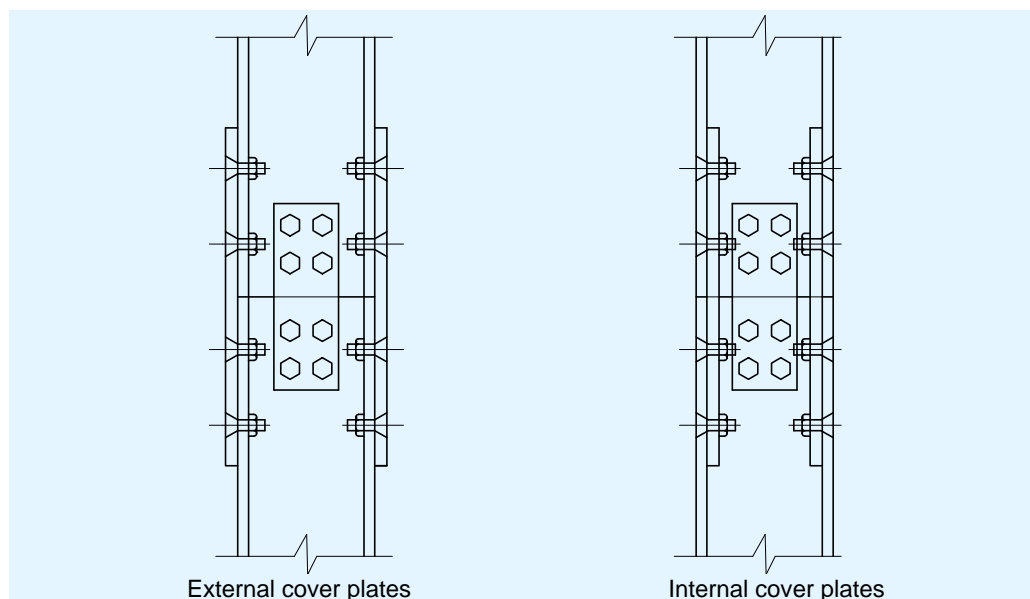

Figure 4.6 Column splice with countersunk bolts

4.5 Structural options for floor systems

4.5.1 General arrangement of floors

A wide range of floor solutions are available. Typical solutions are given in Table 4.2, and more details in the following sections. Although steel solutions are appropriate for short spans (typically 6 m to 9 m), steel has an important advantage over other materials in that long span solutions (between 12 m and 18 m) can be easily provided. This has the key advantage of column-free space, allowing future adaptability, and fewer foundations.

Floors spanning onto the steel beams will normally be either precast concrete units, or composite floors. The supporting beams may be below the floor, with the floor bearing on the top flange (often known as “downstand” beams), or the beams may share the same zone with the floor construction, to reduce the overall depth of the zone. The available construction zone is often the determining factor when choosing a floor solution.

Beams within the floor zone are known as slim floor beams, or integrated beams. Beams may be non-composite, or composite. In composite construction shear connectors are welded to the top flange of the beam, transferring load to the concrete floor. Shear connectors are often welded on site to the top flange of the beam which has been left unpainted, through the steel decking (known as “through-deck” welding). Despite extensive testing and research that demonstrates the adequacy of through-deck welding, some authorities prefer that the studs are welded off site, and the deck must therefore be single span, or must be punctured to fit over the shear connectors. Alternatively, shear connectors can be mechanically fixed (often shot fired) through the decking to the beam.

Precast concrete units may be used for low rise frames, but composite floors are common in both low rise and high rise structures.

Table 4.2 Typical floor solutions

Form of construction	Typical solution
Low rise, modest spans, no restriction on construction depth	downstand beams precast units or composite floors
Modest spans (less than 9 m), restricted construction depth	integrated solutions – precast or composite floors
Low rise, long span (e.g. 15 m)	downstand beams in the façade precast concrete units (15 m), composite floors with secondary steel beams spanning 15 m
Medium and high rise, modest spans, no restriction on construction depth	downstand beams, composite construction
Medium and high rise, long spans (to 18 m) restricted construction depth	composite floors with cellular long span secondary steel beams

4.5.2 Composite beam arrangements

Composite beams support composite slabs, which span between the beams. For design of orthogonal grids, two generic beam arrangements may be considered:

- Long span secondary beams, supported by shorter span primary beams (see Figure 4.7). In this case, the beam sizes can be selected so that the primary and secondary beams are of approximately equal depth.
- Long span primary beams, supporting shorter span secondary beams (see Figure 4.8). In this case, the primary beams are relatively deep.

Cellular beams are more efficient when used for long span secondary beams, whereas fabricated beams are more efficient for long span primary beams, where shear forces are higher. It is also possible to eliminate secondary beams

by using long span composite slabs and primary beams directly attached to the columns.

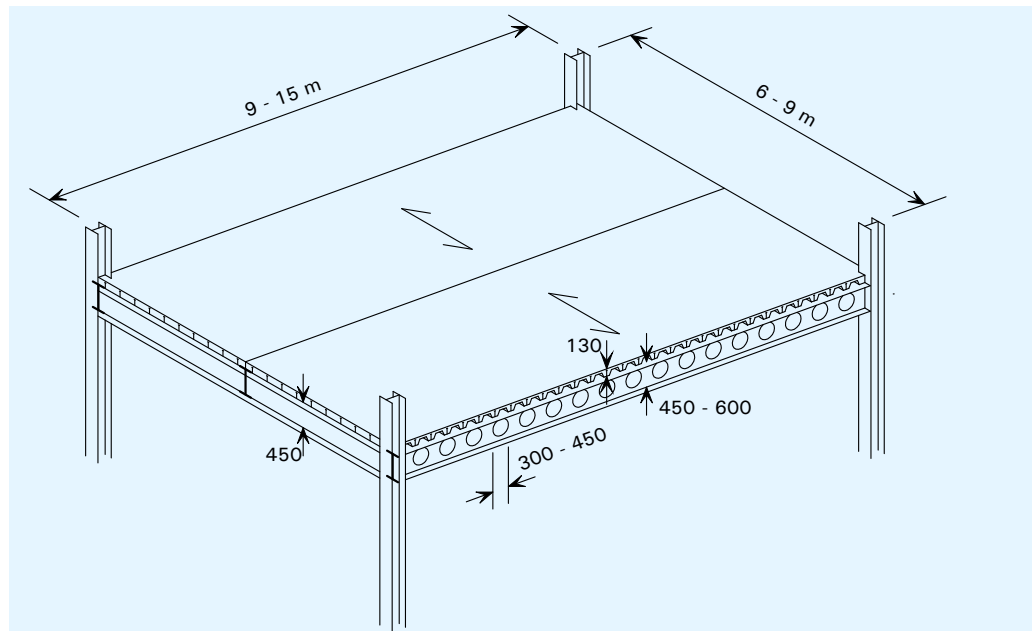

Figure 4.7 Typical long span secondary beams (span of slab is indicated)

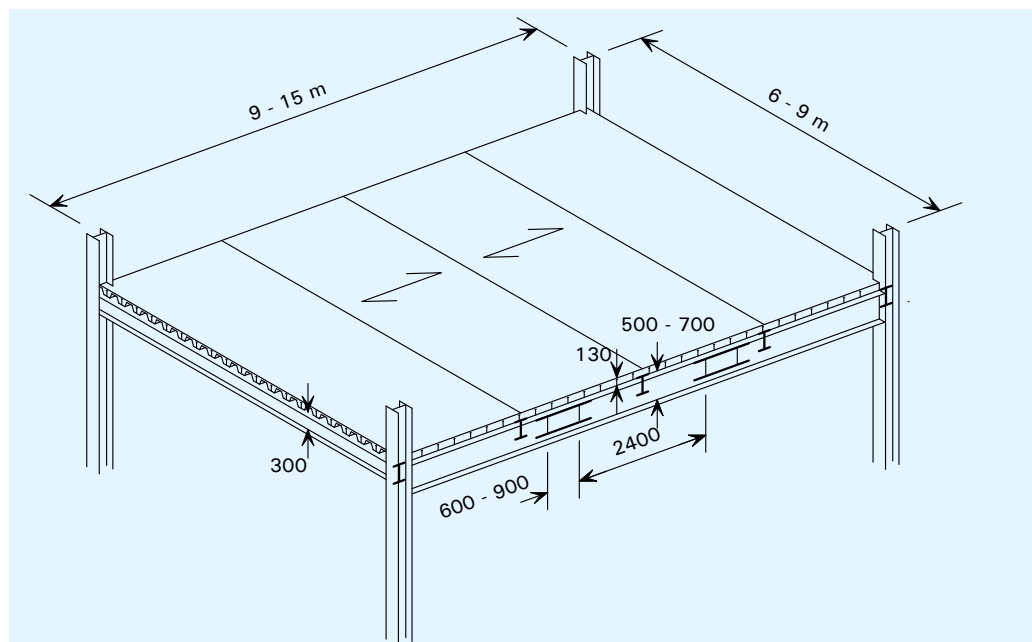

Figure 4.8 Typical long span primary beams and shorter span secondary beams (span of slab is indicated)

Integrated beams are a special case in which beams span directly between columns and secondary beams are eliminated. These beams are generally used in square grids, as illustrated in Figure 4.9. The slab is supported by the bottom flange or extended bottom plate of the beam and may be in the form of a deep composite slab or a hollow core concrete slab.

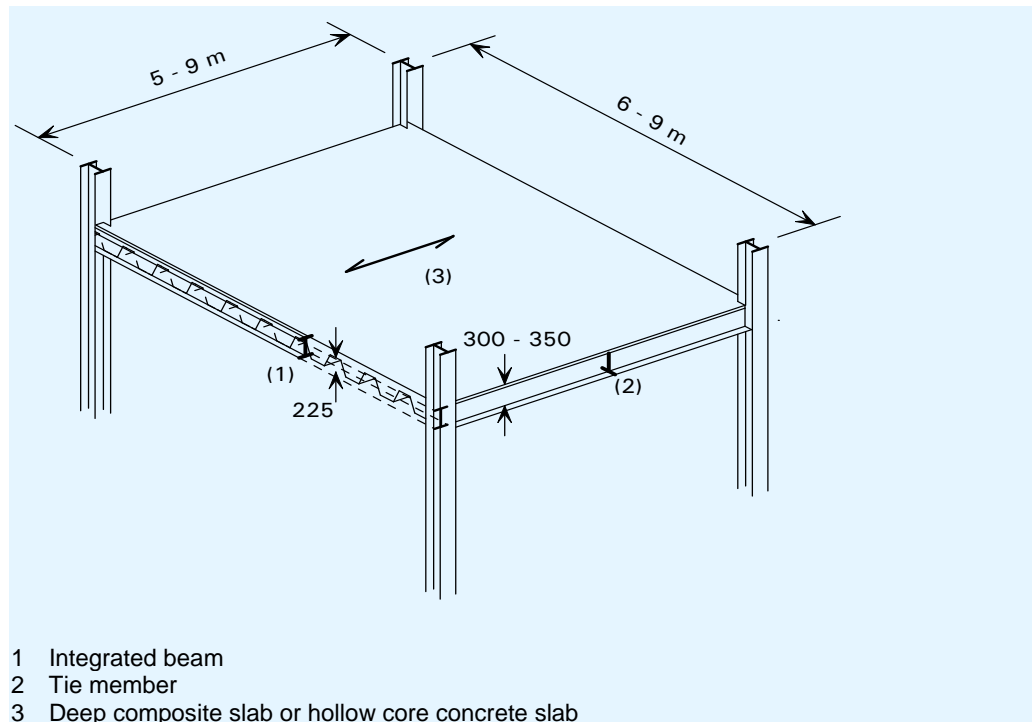

Figure 4.9 Integrated beams or slim floor (span of slab is indicated)

The span range of various structural options in both steel and concrete are illustrated in Figure 4.10. Long span steel options generally provide for service integration for spans of over 12 m. Cellular beams and composite trusses are more efficient for long span secondary beams, whereas fabricated beams are often used for long span primary beams.

	Span (m)					
	6	8	10	13	16	20
Reinforced concrete flat slab	█					
Integrated beams and deep composite slab	█	█				
Integrated beams with precast slabs	█	█	█			
Composite beams and slab		█	█	█		
Fabricated beams with web openings			█	█	█	█
Cellular composite beams			█	█	█	
Composite trusses					█	█

Figure 4.10 Span range of various structural options

4.5.3 Features of long span construction

Long span beams have gained in popularity in the commercial building sector because they offer the following benefits in design and construction:

- Internal columns are eliminated, leading to more flexible and efficient use of internal space
- Services can be integrated within the depth of the structure, and so the floor-to-floor depth is not increased
- Fewer components are required (typically 30% fewer beams) leading to reduced construction and installation time
- Fire protection costs can be reduced due to the massivity (weight : exposed profile) of the longer span members
- For cellular beams, multiple circular ducts for services are cheaper than rectangular ducts
- Steelwork costs are not increased significantly, despite the longer spans
- Overall building costs are increased by a negligible amount (less than 1%).

4.5.4 Approximate steel quantities

For estimating purposes in the design of office buildings, representative weights of steel may be used for buildings of rectangular plan form. These quantities will increase significantly for non rectangular or tall buildings or for buildings with atria or complex façades.

The approximate quantities are presented in Table 4.3, and are expressed in terms of the total floor area of the building, and do not include steelwork used in the façade, atrium or roof.

Table 4.3 Approximate steel quantities for estimating purposes

Form of Building	Approximate steel quantities (kg/m ² floor area)			
	Beams	Columns	Bracing	Total
3 or 4-storey building of rectangular form	25–30	8–10	2–3	35–40
6–8-storey building of rectangular form	25–30	12–15	3–5	40–50
8–10-storey building with long spans	35–40	12–15	3–5	50–60
20-storey building with a concrete core	25–30	10–13	1–2	40–50
20-storey building with a braced steel core	25–30	20–25	8–10	55–70

4.6 Factors influencing structural arrangements

The construction programme will be a key concern in any project, and should be considered at the same time as considering the cost of structure, the services, cladding and finishes. The structural scheme has a key influence on programme and cost, and structural solutions which can be erected safely, quickly to allow early access for the following trades.

4.6.1 Site conditions

Increasingly, structures are constructed on 'brownfield' sites, where earlier construction has left a permanent legacy. In city centres, a solution involving fewer, although more heavily loaded foundations are often preferred, which leads to longer spans for the super-structure.

A confined site can place particular constraints on the structural scheme, for example the physical size of the elements that can be delivered and erected. Access may demand that the steel is erected directly from a delivery lorry in the road. This may prevent working at certain times in the day making the erection programme relatively inflexible. A mobile erection platform provides temporary storage and speeds up the installation process, as shown in Figure 2.2.

4.6.2 Cranes

The number of cranes on a project will be dominated by:

- The site footprint – whether a sensible coverage of the building site can be achieved, including off-loading.
- The size of the project – which dictates whether more than one crane is economic. In city centre projects, tower cranes are often located in a lift shaft or atrium.
- Use of additional mobile cranes – multi-storey structures are generally erected using a tower crane, which may be supplemented by mobile cranes for specific heavy lifting operations.

As an indication, an erection rate of between 20 and 30 pieces per day is a reasonable installation rate. With average weights of the components, this equates to approximately 10 to 12 tonnes of steel per day. There is therefore benefit in using fewer, long span beams. Where possible, prefabrication reduces the number of items to be lifted, and increases erection rates.

4.6.3 Installation of composite floors

Composite floors comprise profiled steel decking, which is lifted onto the steelwork in bundles and usually man-handled into position. Safety nets are erected immediately after the steelwork and before the decking placement. Steelwork already erected at upper levels does not prevent decking being lifted and placed, although decking is usually placed as the steelwork is erected. Completed floors may be used as a safe working platform for subsequent erection of steelwork, and allow other works to proceed at lower levels, as shown in Figure 4.11. For this reason, the upper floor in any group of floors (usually three floor levels) is often concreted first.



Figure 4.11 Composite floors create a safe working platform during construction

4.6.4 Installation of precast concrete slabs

Placing of precast concrete slabs becomes difficult if they are lowered through erected steelwork. Better practice is to place the slabs as the steelwork for each floor is erected, and for the supply and installation to be part of the Steelwork Contractor's package. Generally, columns and floor steelwork will be erected, with minimal steelwork at upper levels sufficient to stabilise the columns, until the precast slabs have been positioned. Steelwork for the upper floors will then continue.

4.7 Structure – service integration

Most large office-type structures require air conditioning or 'comfort cooling', which will necessitate both horizontal and vertical distribution systems. The provision for such systems is of critical importance for the superstructure layout, affecting the layout and type of members chosen.

The basic decision either to integrate the ductwork within the structural depth or to simply suspend the ductwork at a lower level affects the choice of member, the fire protection system, the cladding (cost and programme) and overall building height. Other systems provide conditioned air from a raised floor.

The most commonly used systems are the Variable Air Volume system (VAV) and the Fan Coil system. VAV systems are often used in buildings with single owner occupiers, because of their lower running costs. Fan Coil systems are often used in speculative buildings because of their lower capital costs.

Generally, a zone of 400 mm will permit services to be suspended below the structure. An additional 150–200 mm is usually allowed for fire protection, ceiling and lighting units and a nominal deflection (25 mm). Terminal units (Fan coil or VAV units) are located between the beams where there is more space available.

Service integration is achieved by passing services through penetrations in the supporting steelwork. These may be individual openings formed in steel beams, or multiple regular openings.

Cellular beams permit multiple circular ducts to be distributed around the building as shown in Figure 4.12, particularly where passing from the building core. Elongated openings may be created in cellular beam construction, as illustrated in Figure 4.13.



Figure 4.12 Cellular beam with multiple service ducts

If there are no overall height constraints, services can be accommodated below the floor structure. The penalty is an increased construction depth of each floor, and increased cladding area.



Figure 4.13 Elongated openings with horizontal stiffeners

An example of service distribution below the floor of an integrated beam is illustrated in Figure 4.14. The shallowest integrated floor solution is achieved with deep decking and asymmetric steel beams, where services can be located in the ribs in the decking, and pass through the supporting steelwork. The size of the ducting and service components is obviously limited in this arrangement.



Figure 4.14 Service distribution below the floor of an integrated beam floor

5 FLOOR SYSTEMS

In addition to their primary load-resisting function, floors transfer horizontal loads to the vertical bracing. In addition, floor slab, beams and columns have to satisfy a specified fire resistance (typically 60 to 120 minutes).

Services may be integrated with the floor construction, or be suspended below the floor (as described in Section 4.6). In commercial buildings, raised floors allow services (particularly electrical and communication services) to be distributed easily.

This section describes various floor systems often used in multi-storey buildings. The main characteristics of each floor system are described, with guidance on important design issues. This section does not contain detailed design procedures but directs the reader to the sources of design guidance.

The following floor systems are covered:

- Composite beams and composite slabs with steel decking
- Long-span composite beams often with service openings
- Cellular composite beams with composite slabs and steel decking
- Integrated beams with precast concrete units
- Composite and non-composite beams with precast concrete units.

5.1 Composite construction

In the following sections, design approaches are presented for composite construction. Decking may have a re-entrant or trapezoidal profile – re-entrant decking uses more concrete than trapezoidal decking, but has increased fire resistance for a given slab depth. Trapezoidal decking generally spans further than re-entrant decking, but the shear stud resistance is reduced due to the influence of the profile shape.

Generally, normal weight concrete (NWC) is used, although lightweight concrete (LWC) is structurally efficient and in some countries widely available.

5.2 Composite beams and composite slabs with steel decking

5.2.1 Description

Composite construction consists of downstand steel beams with shear connectors (studs) welded to the top flange to enable the beam to act compositely with an *in situ* composite floor slab.

The composite slab comprises profiled decking of various shapes that span 3 m to 4 m between secondary beams. The generic deck profiles are illustrated in

Figure 5.1 together with their typical slab depths. A ‘target’ slab depth of 130 mm is often used for 50 or 60 mm deep deck profiles, increasing to 150 mm for 80 mm deep deck profiles. Steel thicknesses of 0,8 mm to 1,2 mm are used depending on the deck spans.

The decking is normally designed to support the wet weight of the concrete and construction loading as a continuous member over two or three spans, but the composite slab is normally designed as simply supported between beams. Sufficient composite action occurs that it is generally the construction condition that controls the maximum spans that can be designed. Unpropped decking is preferred for reasons of speed of construction.

The secondary beams in the floor grid are supported by primary beams. These beams are usually designed as composite, but edge beams can be designed as non-composite, although shear connectors may be used for structural integrity and wind loads. A typical example of a composite beam used as an edge beam is shown in Figure 5.2.

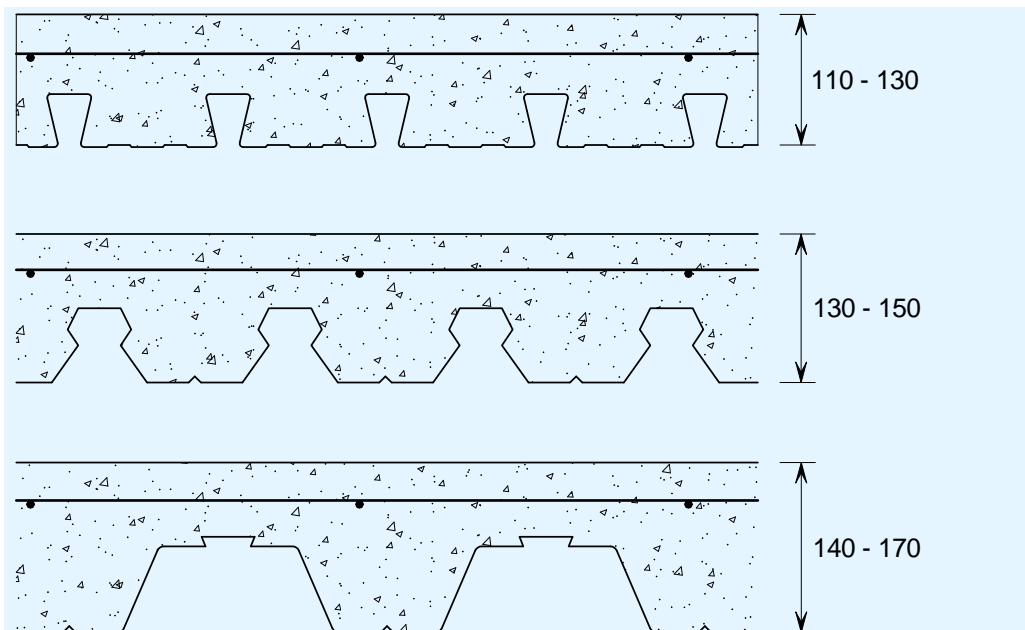

Figure 5.1 Decking profiles used in composite construction

The shear connectors are normally site-welded through the decking to provide a secure fixing to the beam, and to enable the decking to provide restraint to the beam during the construction stage.

Mesh reinforcement, normally of 140 mm to 200 mm²/m cross-sectional area, is placed in the slab to enhance the fire resistance of the slab, to help distribute localised loads, to act as transverse reinforcement around the shear connectors and to reduce cracking in the slab over the beams.

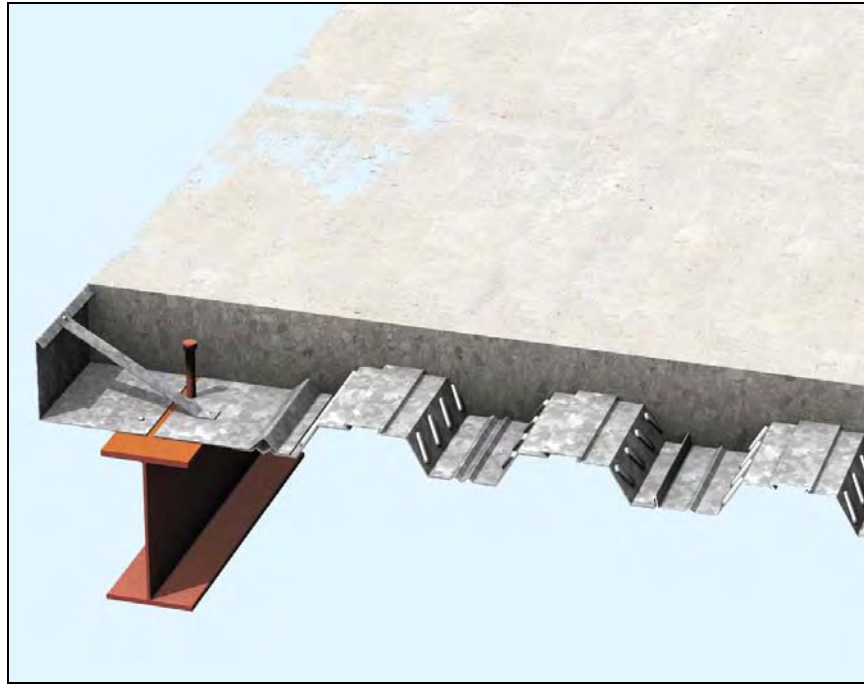

Figure 5.2 Edge beam in composite construction

5.2.2 Typical beam spans and design criteria

Secondary beams are typically 6 m to 15 m span at 3 m to 4 m spacing (3,75 m is generally the preferred maximum span of the slab). Primary beams are designed with spans of 6 m to 12 m, when using IPE sections. A rectangular floor grid is often used, in which the secondary beams span the longer distance, in order that the secondary and primary beams are of similar size. A typical structural arrangement is illustrated in Figure 5.3.

Edge beams may be deeper than internal beams because of serviceability requirements of the cladding. Also, the use of composite edge beams requires placing of U-bars around the shear connectors.

Limitations on total deflection will usually govern for secondary beams using S355 steel. Bending resistance will usually govern for most primary beams in S235 or S275.

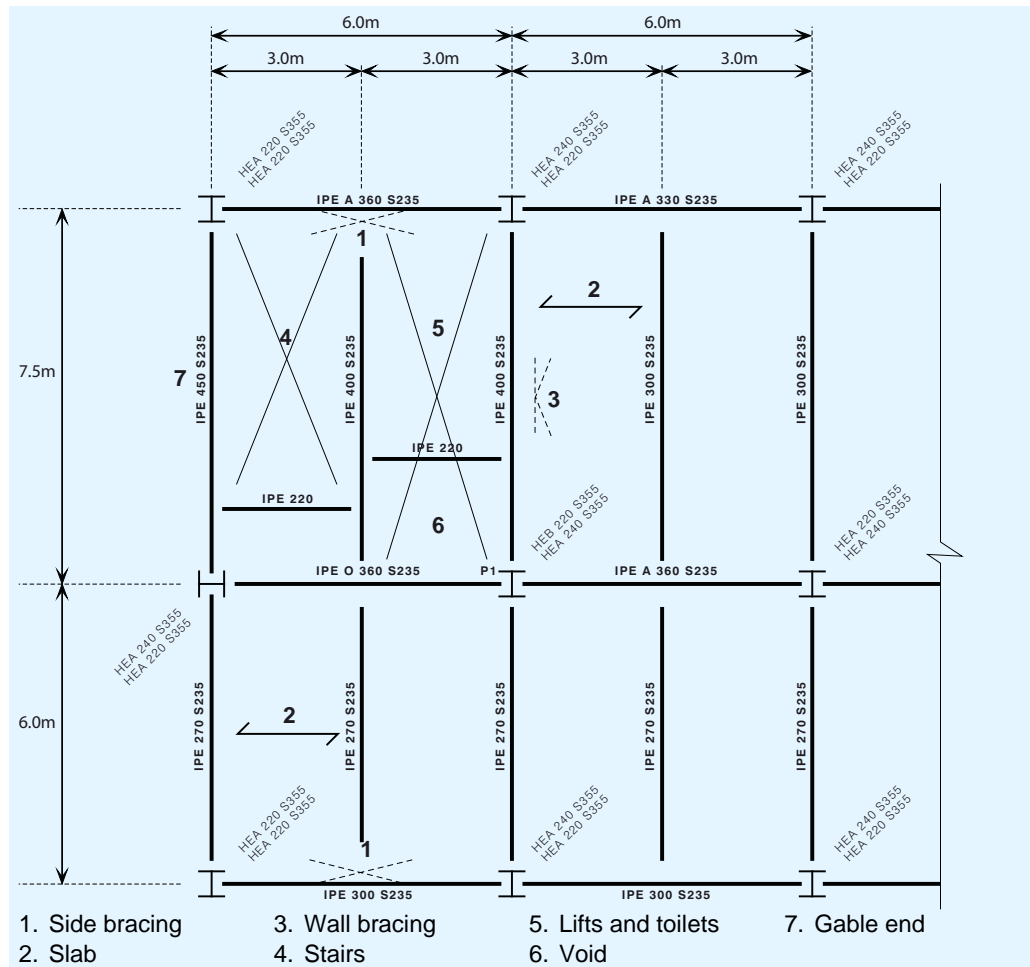

Figure 5.3 Short-span composite beam – example of floor steelwork arrangement for 4-storey rectangular plan building

5.2.3 Services integration

Heating and ventilation units can be positioned between beams, but ducts will generally pass below shallow beams. Typically, for the 7,5 m × 6 m floor grid shown above, the overall floor zone is 1100 mm to 1200 mm allowing for 150 mm raised floor and 400 mm deep air conditioning ducts below the beams. The overall floor zone is illustrated in Figure 5.4. This floor depth may reduce to 700 mm in the case without air conditioning services.

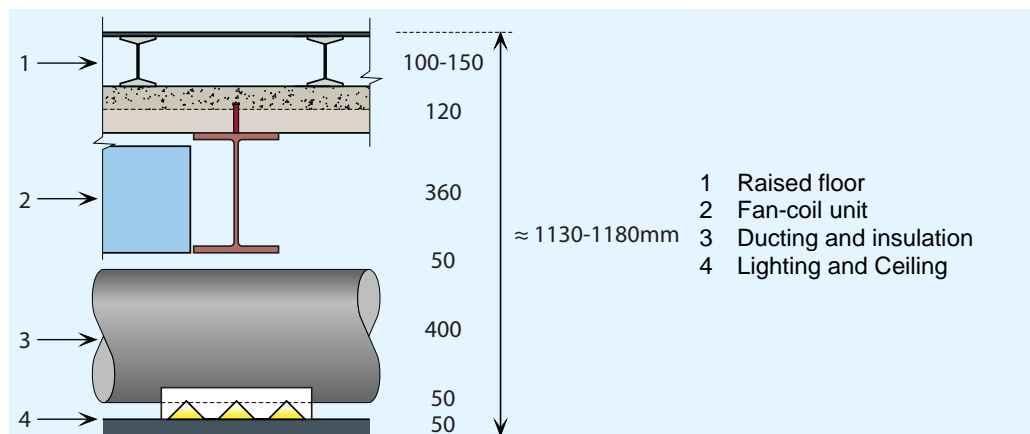

Figure 5.4 Overall floor zone – typical short-span composite construction

5.2.4 Fire protection

Beams (typically):

Intumescent coating 1,5 mm thick for up to 90 minutes fire resistance

Board protection 15-25 mm thick for up to 90 minutes fire resistance

Columns (typically):

Board protection 15 mm thick for up to 60 minutes fire resistance

Board protection 25 mm thick for 90 minutes fire resistance

Table 5.1 Sizes of composite secondary beams using IPE or HE sections (S235 steel) in a floor grid

Rolled steel beam	Maximum span of secondary beam				
	6 m	7,5 m	9 m	10,5 m	12 m
Minimum weight	IPE 270A	IPE 300	IPE 360	IPE 400	IPE 500
Minimum depth	HE 220A	HE 240A	HE 280A	HE 320A	HE340B

Variable action = 3 kN/m² plus 1 kN/m² for partitions

Slab depth = 130 mm; Beam spacing = 3 m

Table 5.2 Maximum spans of composite secondary beams for typical office loading

IPE	Span (m)	HEA	Span (m)	HEB	Span (m)
200	5,0	200	5,8	200	6,7
220	5,6	220	6,5	220	7,7
240	6,2	240	7,3	240	8,6
-	-	260	8,0	260	9,3
270	7,0	280	8,7	280	9,9
300	7,9	300	9,6	300	10,9
330	8,4	320	10,3	320	11,6
-	-	340	11,3	340	12,3
360	9,4	360	11,9	360	12,9
400	10,4	400	13,1	400	13,8
450	12,2	450	14,2	450	14,7
500	13,6	500	15,1	500	15,6
550	14,7	550	15,9	550	16,4
600	15,7	600	16,6	600	17,1

Variable action = 3 kN/m² plus 1 kN/m² for partitions

Slab depth = 130 mm; Beam spacing = 3 m

Table 5.3 Sizes of composite primary beams (S235 steel) in a floor grid

Span of secondary beams	Maximum span of primary beam				
	6 m	7,5 m	9 m	10,5 m	12 m
6 m	IPE 360	IPE 400	IPE 450	IPE 550	IPE 600R
7,5 m	IPE 400	IPE 450	IPE 550	IPE 600R	IPE 750 × 137
9 m	IPE 450	IPE 500	IPE 600	IPE 750 × 137	IPE 750 × 173

Variable action = 3 kN/m² plus 1 kN/m² for partitions

Slab depth = 130 mm; Beam spacing = 3 m

5.3 Long-span composite beams with web openings

5.3.1 Description

Long span composite beams are often designed with large web openings to facilitate integration of services, as shown in Figure 5.5. Grids are either arranged so that the long span secondary beams are placed at 3 m to 3,75 m spacing and are supported by shorter span primary beams. Alternatively, short-span secondary beams (6 - 9 m span) are supported by long-span primary beams. Service openings can be circular, elongated or rectangular in shape, and can be up to 70% of the beam depth. They can have a length/depth ratio typically of up to 3,5. Web stiffeners may be required around large openings.



Figure 5.5 Beams with various opening sizes and with off-site fire protection

5.3.2 Beam spans and design criteria

Long-span secondary beams: 9 m to 15 m span at 3 m to 3,75 m spacing.

Long-span primary beams: 9 m to 12 m span at 6 m to 9 m spacing.

A typical structural arrangement which eliminates internal columns is illustrated in Figure 5.6. Elongated or rectangular openings should be located in areas of low shear, e.g. in the middle third of the span for uniformly loaded beams. Other guidance on opening sizes is presented in Figure 5.7. Critical checks for long span beams are usually deflections and dynamic response. Shear resistance at large openings close to the supports or point loads may be critical.

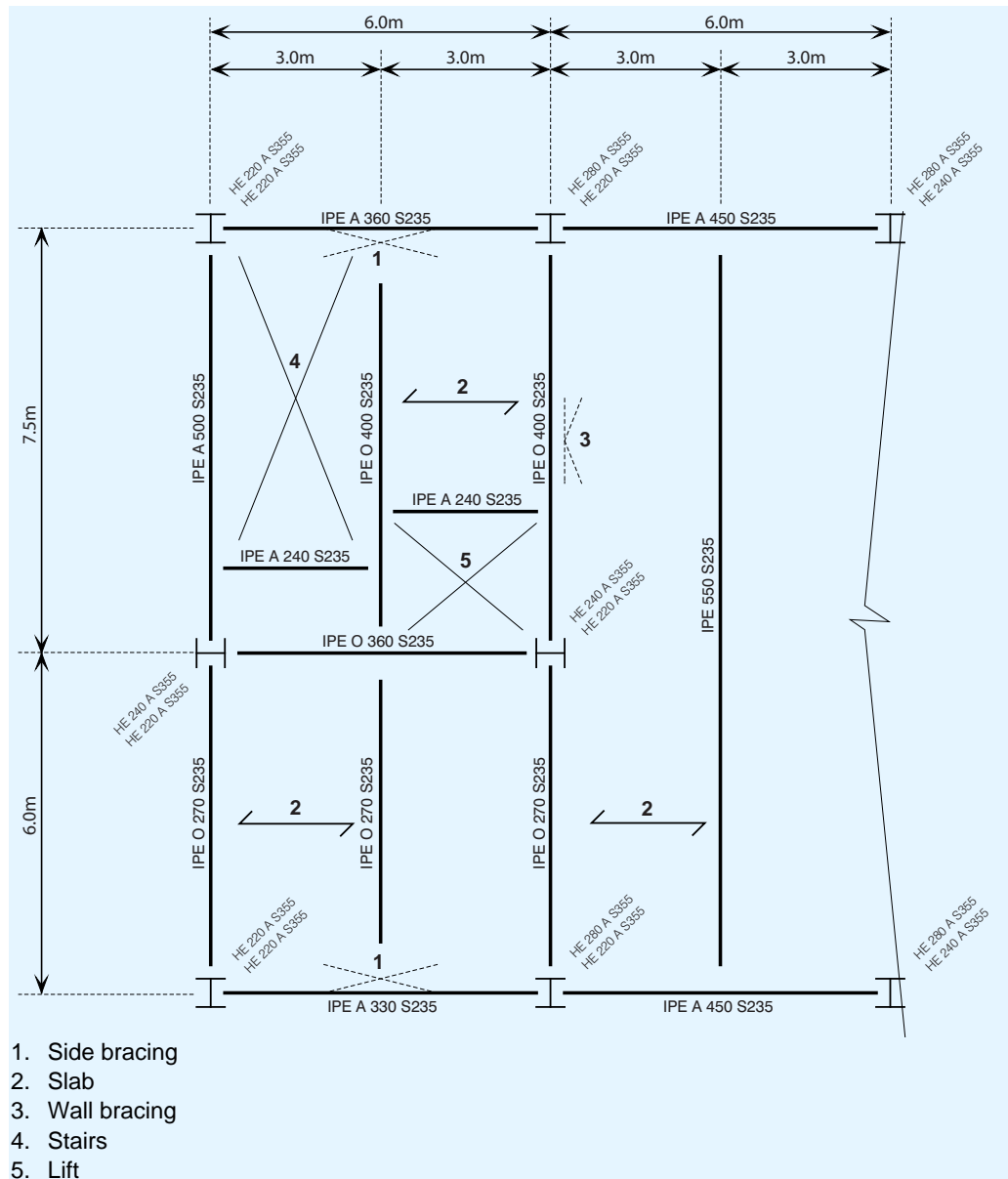

Figure 5.6 Long-span composite beams (with web openings)

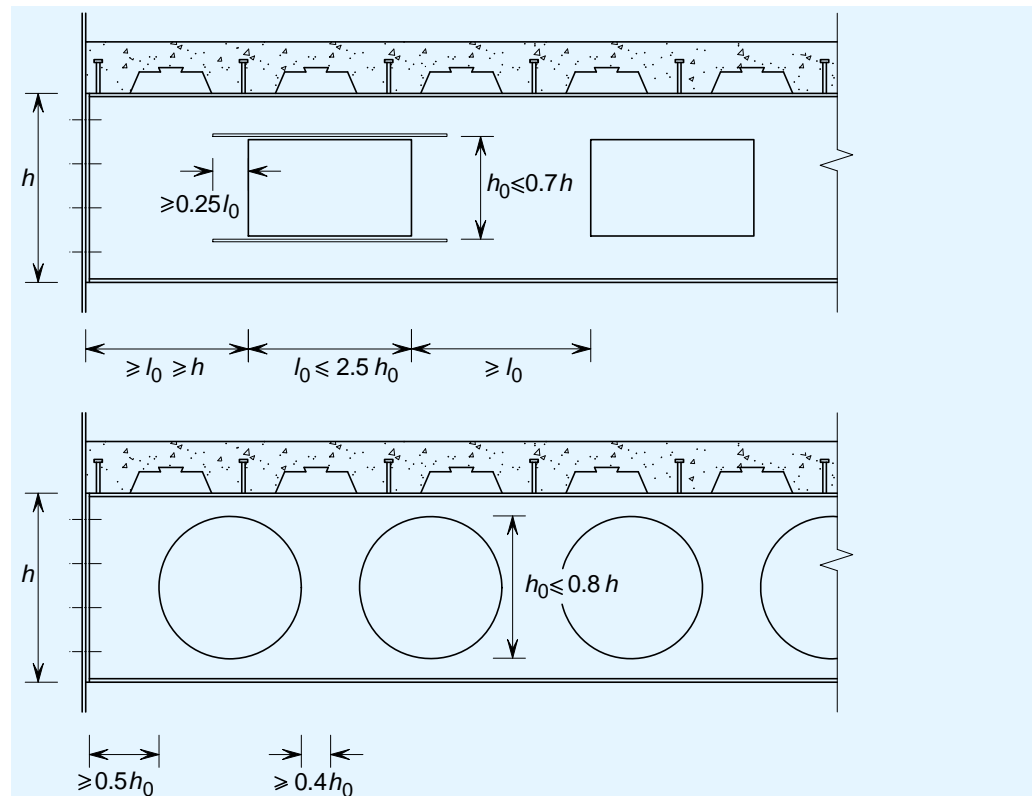

Figure 5.7 Limits of sizes and spacing of circular and rectangular web openings

5.3.3 Services integration

Service ducts may pass through openings in the web of the beams. Ducts for air conditioning are approximately 400 mm deep, but vary between manufacturers. Larger service units, which are typically 450 mm deep, but up to 750 mm for variable air volume (VAV) units can be situated between beams. The overall depth of the floor zone will be typically:

1000 mm for 13,5 m span beam (with 300 mm deep web openings)

1200 mm for 15 m span beams (with 400 mm deep web openings)

5.3.4 Fire protection

Fire protection may be in the form of board protection or intumescent coating (intumescent coatings can be applied off-site as a single coating up to 1,8 mm thick in order to achieve 90 minutes fire resistance), as illustrated in Figure 5.5.

5.4 Cellular composite beams with composite slab and steel decking

5.4.1 Description

Cellular beams are beams with circular openings with regular spacing along their length, as illustrated in Figure 5.8. The beams are made by cutting and re-welding hot rolled steel sections. Openings, or 'cells', are normally circular, which are ideally suited to circular ducts, but can be elongated, rectangular or hexagonal. Cells may have to be filled in to create a solid web at positions of high shear, such as at supports or either side of point loads along the beam.

The size and spacing of the openings can be restricted by the fabrication method. However, the full range of section sizes is available from which to choose the sizes of the top and bottom chords. For composite design, the top chord is generally chosen as a lighter section than the bottom chord

Cellular beams can be arranged as long-span secondary beams, supporting the floor slab directly, or in some cases, as long-span primary beams supporting other cellular beams or I section secondary beams.



Figure 5.8 Long-span secondary cellular beams with regular circular openings

5.4.2 Beam spans and design criteria

Secondary beams should be spaced at 3 m to 3,75 m to avoid temporary propping of the decking during construction. Opening sizes are typically 60 to 80% of the beam depth. Stiffeners may be required for elongated openings. Large (elongated or rectangular) openings should be located in areas of low shear, e.g. in the middle third of span for uniformly loaded beams.

A structural arrangement for corner of a floor around an atrium is illustrated in Figure 5.9. In this case, the floor grid is 15 m \times 7,5 m, in which the cellular beams are 15 m span and 670 mm deep. Internal beams are eliminated except around the service cores.

Shear or buckling of the web posts may occur between openings, particularly near high point loads or adjacent to elongated openings. In this case, the spacing of the openings should be increased or heavier sections used. Typical chord sizes for 12 m to 18 m span cellular secondary beams at 3 m spacing are presented in Table 5.4.

Table 5.4 Sizes of composite cellular beams as secondary beams (IPE/HE sections in S355 steel)

Cellular beam parameters	Maximum span of cellular beam (m)				
	12 m	13,5 m	15 m	16,5 m	18 m
Opening diameter (mm)	300	350	400	450	500
Beam depth (mm)	460	525	570	630	675
Top chord	IPE 360	IPE 400	IPE 400	IPE 450	IPE 500
Bottom chord	HE 260A	HE 300A	HE 340B	HE 360B	HE 400M

Variable action = 3 kN/m² plus 1 kN/m² for partitions
 Slab depth = 130 mm; Beam spacing = 3 m

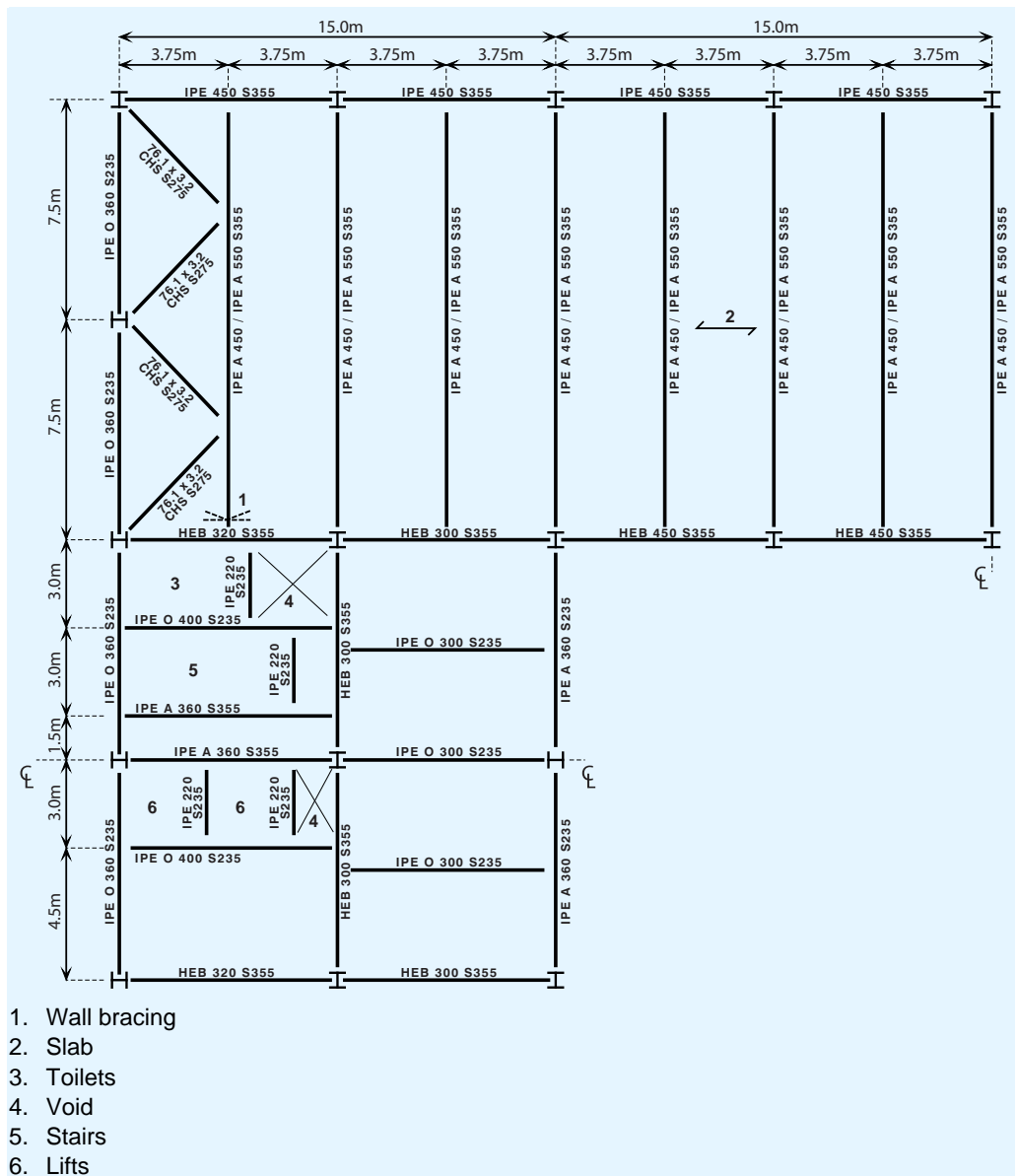

Figure 5.9 Cellular beams (long-span secondary beams) – example of steelwork arrangement at the corner of a 8-storey building with an atrium

5.4.3 Services integration

Regular openings in the web allow ducts to pass through the beams as shown in Figure 5.10. Larger services equipment is located between the beams. Opening sizes should allow for any insulation around the services. Fabrication should be arranged to ensure web openings align through the beams along the building.

The overall floor zone can be as low as 1000 mm for 15 m span beams with regular 400 mm openings, which is much shallower than the case where ducts pass below the beams.

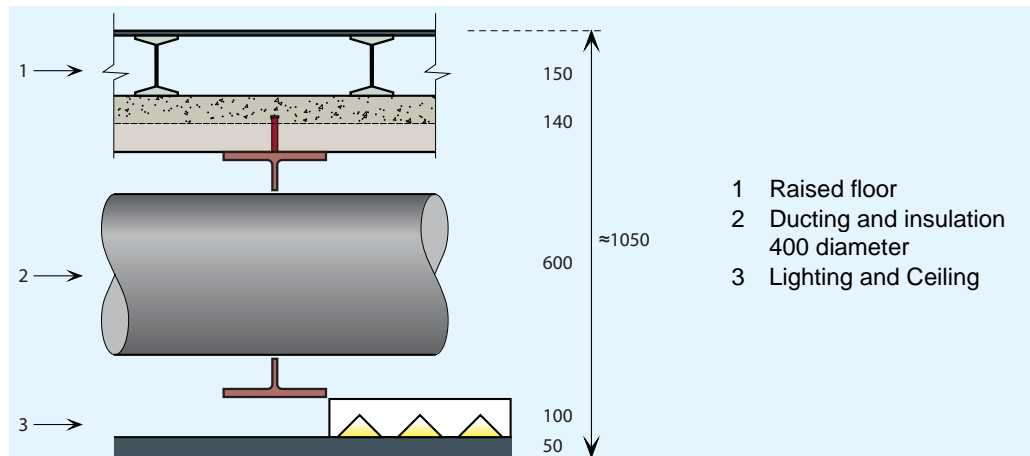

Figure 5.10 Cellular beam – Typical cross-section showing services integration

5.4.4 Fire protection

Intumescent coatings are the preferred fire protection system for cellular beams, and are often applied off-site. Reference 7 gives advice on fire protection of beams with web openings.

5.5 Composite beams with precast concrete units

5.5.1 Description

This system consists of steel beams with shear connectors that are often pre-welded to the top flange as part of the fabrication process. The beams support precast concrete units with a structural concrete infill over the beam between the ends of the units, and often with an additional topping covering the units. The precast concrete (P.C.) units are either hollow core, normally 150 - 260 mm deep, or solid planks of 75 mm to 100 mm depth.

At the supports, deeper P.C. units are either chamfered on their upper face or notched so that the *in situ* concrete fully encases the shear connectors. Narrow openings are created within the hollow core units during the manufacturing process to allow transverse reinforcement to be placed across the beams and embedded in the precast units for approximately 600 mm on either side, as shown in Figure 5.11.

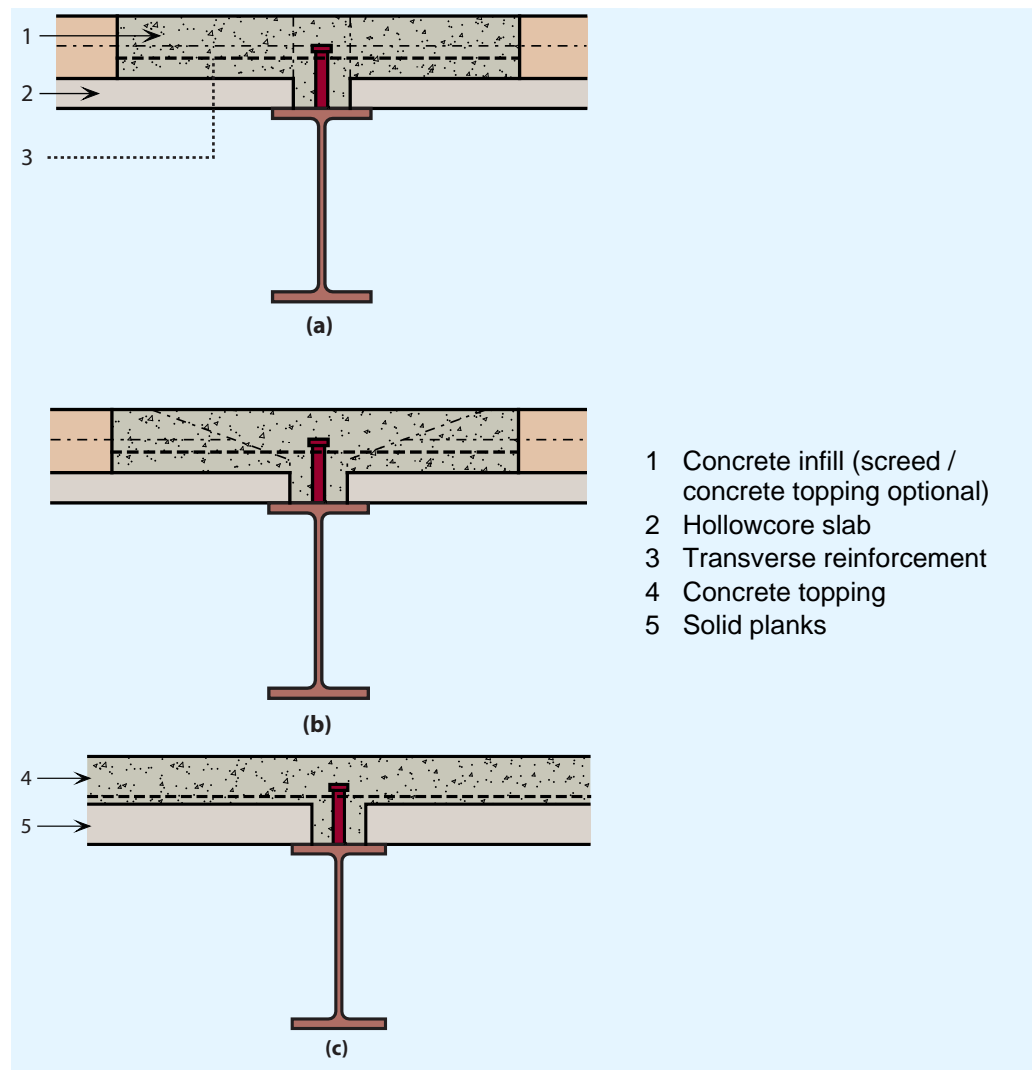

Figure 5.11 Forms of composite beams with precast concrete units
(a) Composite beam with square-ended hollowcore slabs
(b) Composite beam with chamfered-ended hollowcore slabs
(c) Composite beam with precast planks

The shear connectors and transverse reinforcement ensure transfer of the longitudinal shear force from the steel section into the precast concrete unit and the concrete topping. Composite design is not permitted unless the shear connectors are situated in an end gap (between the concrete units) of at least 50 mm. For on-site welding of shear connectors, a practical minimum end gap between concrete units is 65 mm. The shear connector resistance depends on the degree of confinement and *in situ* concrete with 10 mm aggregate is often used. Hollow cores should be back-filled at the supports for a minimum length equal to the core diameter to provide for effective composite action and adequate fire resistance.

Minimum flange widths are required to provide a safe bearing length for the precast units and sufficient gap for effective action of the shear connectors – minimum recommended values are given in Table 5.5.

Table 5.5 Minimum widths for bearing of PC units

	Minimum beam width	
75 mm or 100 mm deep solid precast unit	Internal beam	180 mm
	Edge beam	210 mm
Hollow core precast unit	Internal beam	180 mm
	Edge beam	210 mm
Non-composite edge beam		120 mm

Edge beams are often designed as non-composite, with nominal shear connection provided to meet robustness and stability requirements. These shear connectors are usually site-welded through openings cast in the precast units. Composite edge beams require careful detailing of U-bar reinforcement into slots in the precast concrete units, and a greater minimum flange width.

Temporary bracing providing lateral restraint is often required to reduce the effective length for lateral torsional buckling of the beam during the construction stage, when only one side is loaded. Full torsional restraint in the temporary condition may be difficult to achieve, unless deep restraint members with rigid connections are used, or by developing ‘U-frame action’ involving the beams, the restraint members and rigid connections.

5.5.2 Beam span and design criteria

Long span secondary beams should provide sufficient minimum width to support the P.C. units as given in Table 5.5, so an IPE 400 mm is the minimum practical beam depth. Beams that are placed parallel to the span of the precast units cannot usually be designed compositely.

Edge beams are generally designed as non-composite, but are tied into the floor to meet robustness requirements.

Transverse reinforcement must be provided in all composite design cases, as shown in Figure 5.11 and Figure 5.12.

The critical check is often torsional resistance and twist, or combined torsion and lateral torsional buckling resistance in the construction condition (with loads on one side only).



Figure 5.12 Composite floor construction with precast concrete hollow core units, showing transverse reinforcement bars placed within open cores

5.5.3 Services integration

Main service ducts are located below the beams with larger services equipment located between beams. Allow for 1200 mm overall depth including ceiling and services. Openings can be provided in the beam web but the beams should be designed as non-composite in this case.

5.5.4 Fire protection

Spray, board or intumescent coating may be used as the fire protection systems to beams supporting precast concrete units.

Transverse bars must be carefully detailed into the precast units – extending 600 mm into each unit. For 90 to 120 minutes fire resistance, a 50 mm (minimum) concrete topping is required.

5.6 Non-composite beams with precast units

5.6.1 Description

Precast units may be supported on the top flange of the steel beams, or supported on ‘shelf’ angles. The P.C. units are either in the form of hollow core units, normally 150 – 400 mm deep, or solid planks of 75 mm to 100 mm depth. Hollow core precast concrete units can be used to span up to 15 m (400 mm or deeper). An example of long span precast concrete units being placed on steel beams is shown in Figure 5.13.

Shelf angles are bolted or welded to the beam web, with an outstand leg long enough to provide adequate bearing of the precast unit and to allow installation of the units under the top flange of the beams. Precast concrete units are generally grouted in position. The P.C. units may have either a screed (which may be structural), or a raised floor.



Figure 5.13 Long span precast concrete units being placed on steelwork

Temporary lateral bracing is often required to limit the effective length for lateral torsional buckling of the beam during the construction stage when only one side is loaded.

In order to meet robustness requirements, mesh and a structural topping may be required, or reinforcement concreted into hollow cores and passed through holes in the steel beam web. Tying may also be required between the concrete units and the edge beams.

5.6.2 Beam spans and design criteria

Construction stage loading (precast planks on one side only) must be considered. Temporary bracing may be required. Beams loaded on one side only in the permanent condition should be designed for the applied torsional moment.

When the top flange of a beam supports precast planks, the minimum flange width is 180 mm to allow for minimum bearing and a 30 mm gap between the P.C. units, as illustrated in Figure 5.14.

Shelf angles should project at least 50 mm beyond the beam flange. When shelf angles are provided, 25 mm clearance is required between the end of the concrete unit and the beam flange, as shown in Figure 5.15.

The critical beam check is often torsional resistance, or combined torsion and lateral torsional buckling resistance in the construction condition (with loads on one side only).

5.6.3 Services integration

Main service ducts are located below the beams with larger services equipment located between beams.

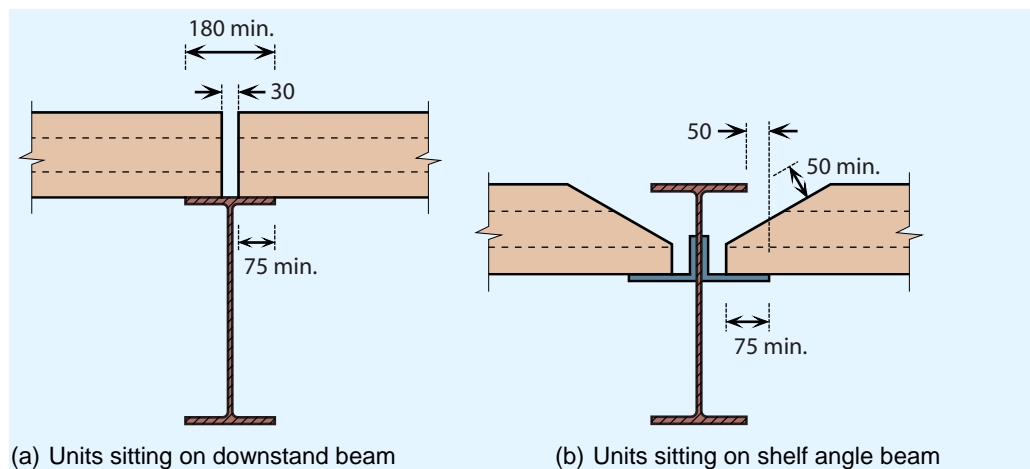

Figure 5.14 Floor construction with precast concrete units in non-composite construction

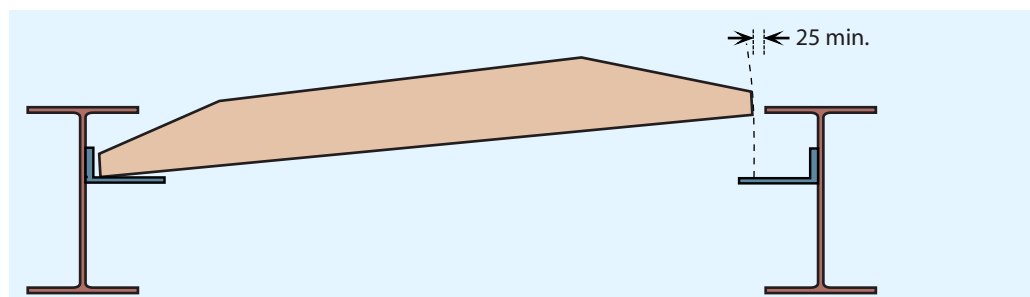

Figure 5.15 Bearing and clearance requirements for precast units on shelf angle beams

5.6.4 Fire protection

Fire protection may be spray, board or an intumescent coating to the beam. Shelf angle beams can achieve 30 minutes fire resistance by up-turning the angles, (the vertical leg is *above* the projecting leg, as shown in Figure 5.15) so that they remain relatively cool in fire.

5.7 Integrated beams with precast concrete units

5.7.1 Description

Precast concrete units may be used as part of a slim floor or integrated beam system, in which the beams are contained within the floor depth, as illustrated in Figure 5.16. Two forms of steel beams are commonly used:

- A steel plate (typically 15 mm thick) may be welded to the underside of an H section. This plate extends beyond the bottom flange by at least 100 mm either side, in order to support the precast concrete units.
- A 20 mm flange plate (typical) may be welded to half of an I section cut along the web.

A structural concrete topping with reinforcement is recommended in order to tie the P.C. units together. The topping thickness should cover the P.C. units by at least 50 mm. If used without a topping, reinforcement should be provided through the web of the beam to tie the floor on each side of the beam together in order to meet robustness requirements.

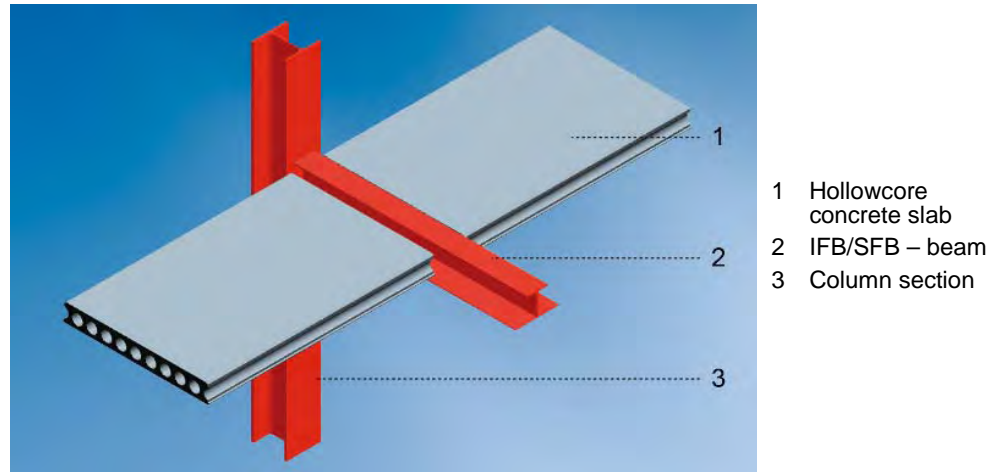

Figure 5.16 Integrated floor beam (slim floor beam) and precast concrete units

A composite integrated beam can be achieved by welding shear connectors (normally 19 mm diameter \times 70 mm long) to the top flange of the steel section. Reinforcement is then placed across the flange into slots prepared in the precast units, or on top of shallow precast units. If the beams are designed compositely, the topping should cover the shear connectors by at least 15 mm, and the precast units by at least 60 mm.

A typical structural arrangement in which the integrated beams span 6 m and the P.C. units span 7,5 m is illustrated in Figure 5.17. In this case, the P.C. units are 200 mm deep and a 60 mm concrete topping is used. The edge beams are IPE, designed as non-composite and are placed below the P.C. units. Nominal shear connectors are provided to meet robustness requirements. In this case, the slab can be cast level with the top of the beam, as shown in Figure 5.18.

5.7.2 Beam spans and design criteria

Ideally, the span of the precast concrete units and the beam span should be optimised to produce a floor thickness compatible with the beam depth. Beams loaded on one side only are relatively heavy because of their torsional loading. Also, torsional effects during construction will need to be checked. A central spine beam with precast units spanning to downstand edge beams (beams located under the P.C. units, but concealed in the wall) will generally be more economic than the P.C. units spanning *along* the building, onto a series of transverse spanning beams.

Composite edge beams require careful detailing of U-bars around the shear connectors and into the precast units or structural topping – therefore non-composite edge beams are preferred.

Critical checks are usually the torsional resistance, combined torsion and lateral torsional buckling resistance in the construction condition (when loaded on one side only), or lateral torsional buckling in the construction condition (with loads on both sides). Deflection may be critical for all types of integrated beams.

Typical beam sizes of slim floor beams and integrated beams for spans of 5 m to 8 m are presented in Table 5.6 and Table 5.7 respectively.

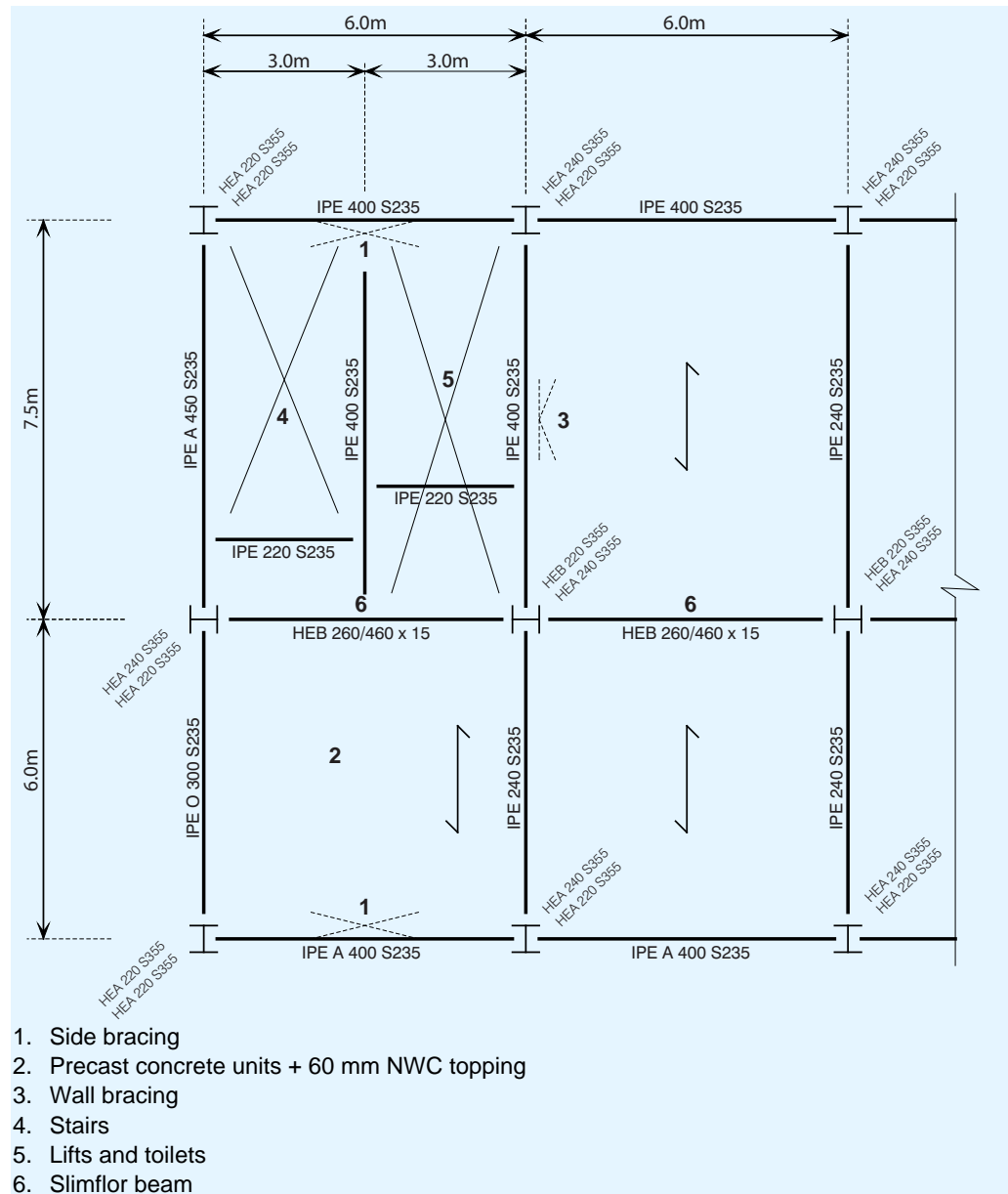

Figure 5.17 Slim floor steelwork arrangement for a four-storey rectangular building (central spine slim floor beam and downstand edge beams)

5.7.3 Services integration

The flat floor soffit allows unrestricted access for services below the floor, as shown in Figure 5.18.

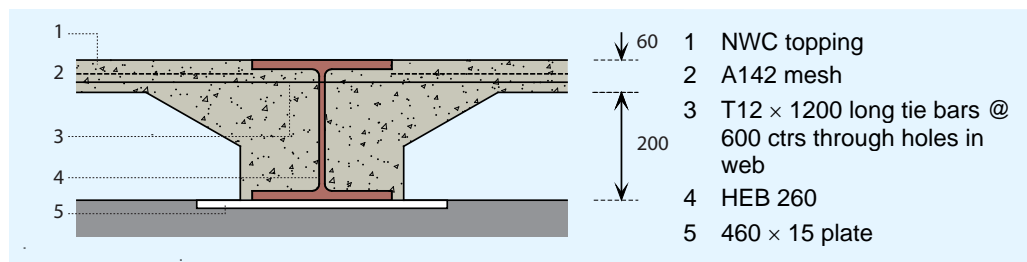

Figure 5.18 Slim floor construction – typical cross-section using precast units

5.7.4 Fire protection

The concrete encasement around the beam is normally sufficient to provide up to 60 minutes fire resistance without additional protection.

For 90 minutes fire resistance, an intumescent coating or board protection to the flange plate is required. Correct detailing of transverse reinforcement is required, particularly for hollow core units, where filling of the cores adjacent to the beam is necessary.

Table 5.6 Span of slim floor beams comprising HE sections and welded bottom plate

Span of slab (m)	Typical beam size for slim floor beam span			
	5 m	6 m	7 m	8 m
5	HE 200A	HE 240A	HE 280A	HE 300A
6	HE 240A	HE 280A	HE 300A	HE 280A
7	HE 280A	HE 300A	HE 280B	HE 300B
8	HE 280A	HE 280B	HE 300B	HE 320B

Slab depth equal to the beam depth, plus 50 mm
The welded plate should be 150 mm wider than the HE section

Table 5.7 Span of integrated beams cut from IPE sections with a welded bottom flange plate

Span of slab (m)	Typical beam size for integrated beam span			
	5 m	6 m	7 m	8 m
5	IPE 400	IPE 500	IPE 550	IPE 600
6	IPE 500	IPE 550	IPE 600	HE 500A
7	IPE 550	IPE 600	HE 500A	HE 600A
8	IPE 600	HE 500A	HE 600A	HE 600B

All section sizes are cut to be half the IPE section sizes given
A 20 mm thick welded bottom flange plate is used in all cases

5.8 Asymmetric beams and deep decking

5.8.1 Description

Asymmetric beams (ASBs) may be used to support composite slabs using deep decking. ASBs are hot rolled steel beams with a wider bottom flange than top. The section may have embossments rolled into the top flange and acts compositely with the concrete encasement without the need for additional shear connectors. The decking spans between the bottom flanges of the beams and supports the loads during construction.

Span arrangements are normally based on a 6 m to 9 m grid, with a slab depth of 280-350 mm. Decking requires propping during the construction stage for spans of more than 6 m. Reinforcing bars (16 – 25 mm diameter) placed in the ribs of the slab give sufficient fire resistance.

ASB sections are generally approximately 300 mm deep. The sections may be rolled with relatively thick webs (equal to or thicker than the flanges), which offer a fire resistance of 60 minutes without additional protection (for normal office loading).

Services can be integrated by forming elongated openings in the webs of the beams, and by locating ducts between the ribs of the decking, as illustrated in Figure 5.19.

Edge beams can be slim floor beams utilising a rectangular hollow section, or downstand beams. Ties, normally Tees with the leg cast in the slab, are used to restrain the columns internally in the direction at right angles to the main beams.

Mesh reinforcement (A142 for 60 minutes fire resistance and A193 for 90 minutes) is placed in the slab over the ASB. If the top flange of the ASB is level with the surface of the concrete, the slabs each side of the ASB should be tied together to meet robustness requirements, normally by reinforcement (typically T12 bars @ 600 centres) passed through the web of the ASB. ASBs are normally designed as non-composite if the concrete cover over the top flange is less than 30 mm.

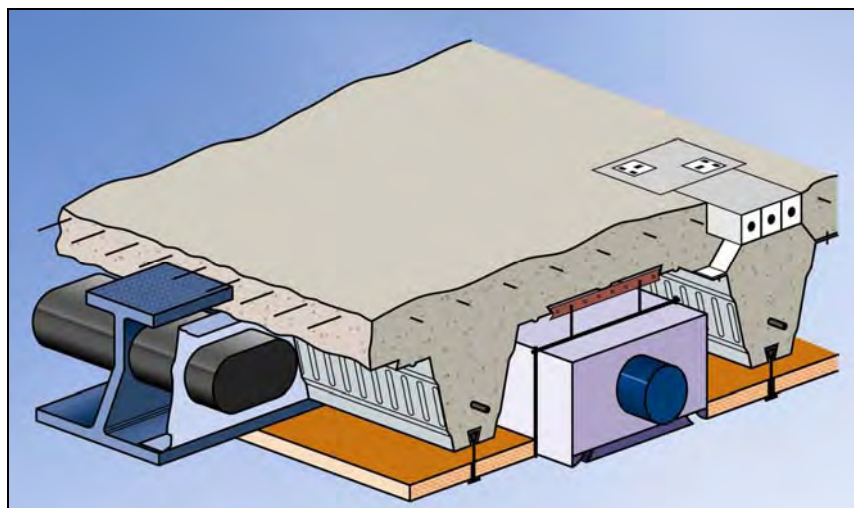

Figure 5.19 Integration of services using asymmetric beams

5.8.2 Beam spans and design criteria

In this form of construction with deep decking, the maximum span of the decking is limited to approximately 6 m for a 300 mm deep slab, in order to avoid temporary propping. The maximum span of the ASB beams is in the range of 6 m to 10 m, depending on their size and spacing.

5.8.3 Services integration

Unrestricted distribution of services below the floor is provided. Small services and ducts (up to 160 mm diameter) can be passed through holes in the beam webs and between ribs in the decking, as shown in Figure 5.20. The following floor zones may be used in scheme design using asymmetric beams and deep decking.

600 – 800 mm with light services (and a raised floor)

800 – 1000 mm with air conditioning (and a raised floor)

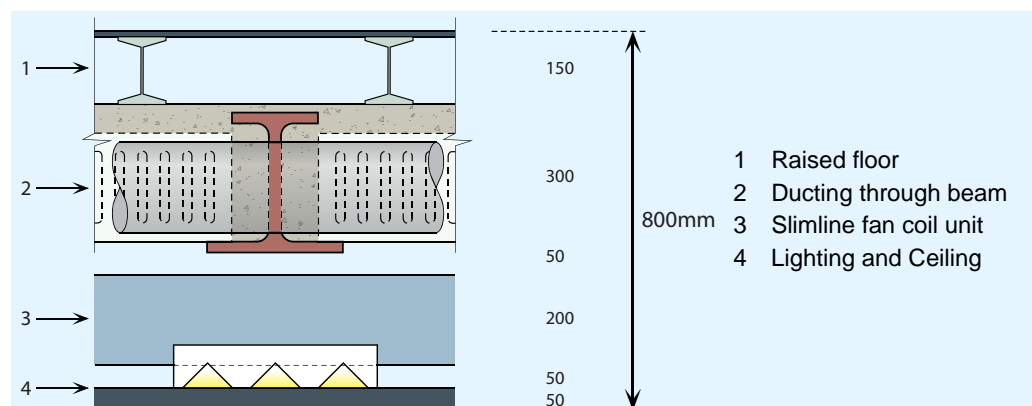

Figure 5.20 Typical floor construction using asymmetric beams and deep decking

5.8.4 Fire protection

Fire engineered ASBs have relatively thick webs and with the web and top flange encased with concrete require no additional fire protection for up to 60 minutes.

Other ASB sections require fire protection for greater than 30 minutes – normally by board to the bottom flange.

5.9 Beam connections

All the floor systems reviewed in this section utilise simple connections (nominal pins), which are not assumed to develop significant moments. To realise this assumption in practice, the connection details must be ductile, in order to accommodate the rotation that develops at the connection.

Full depth connections, where the end plate is welded to the web and flanges, are provided for floor members that are subject to torsion, such as integrated beams or slim floor beams. For any floor solution, the possibility of torsional loading in the construction stage should be checked, as connections with torsional resistance, or temporary restraints may be required.

The use of full depth end plates may mean that the connections can no longer be assumed to be pinned. In many instances, it is assumed that the connection may still be regarded as pinned, as long as the end plate thickness is no more than half the bolt diameter, in S275 steel. Some regulatory authorities may wish to see a calculation to demonstrate the connection classification.

5.9.1 Beam to column connections

When connections are not subject to torsion, simple (vertical shear only) connections are usually detailed. Standard connections are used, with the choice of detail left to the steelwork contractor. The standard connections are the flexible end plate, a fin plate or double angle cleats, shown in Figure 5.21. It is commonly assumed that the types of connections shown in Figure 5.21 are pinned, as long as the plates and angles are relatively thin (10 mm in S275 steel). *Multi-storey steel buildings Part 5: Joint design*^[8] cover the design of pinned connections.

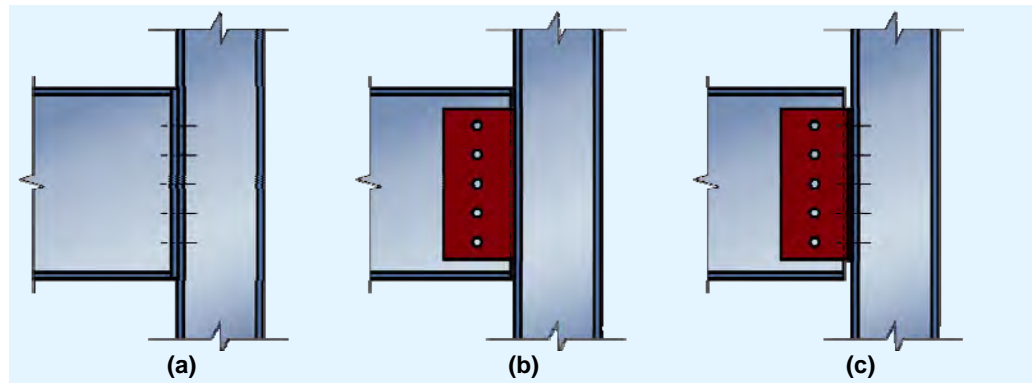

Figure 5.21 Standard beam connections. (a) Flexible end plate (b) Fin plate (c) Double angle cleat

In general, flexible end plates are generally used for beam-to-column connections. Fin plates are often used for beam-to-beam connections.

5.9.2 Beam to beam connections

Beam-to-beam connections also utilise the standard details, although the secondary beam will need to be notched, as shown in Figure 5.22.

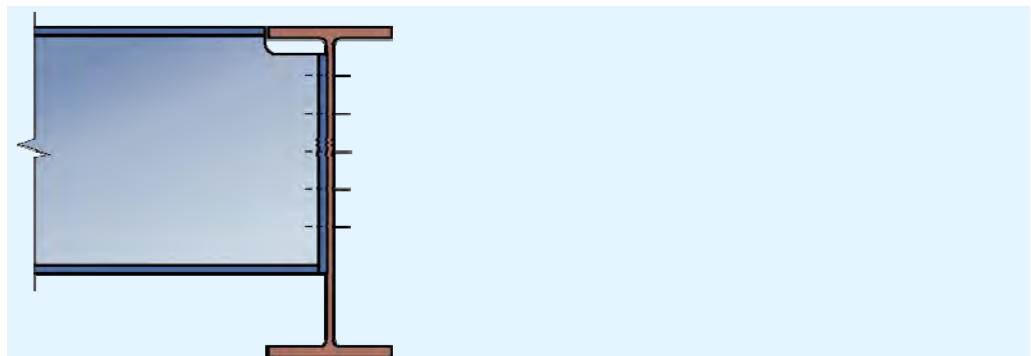

Figure 5.22 Beam to beam connection

5.9.3 Full depth end plates

When connections are subject to torsion, the connection is usually fabricated with a full depth end plate, as shown in Figure 5.23. In these connections, the end plate is welded around the full profile of the member.

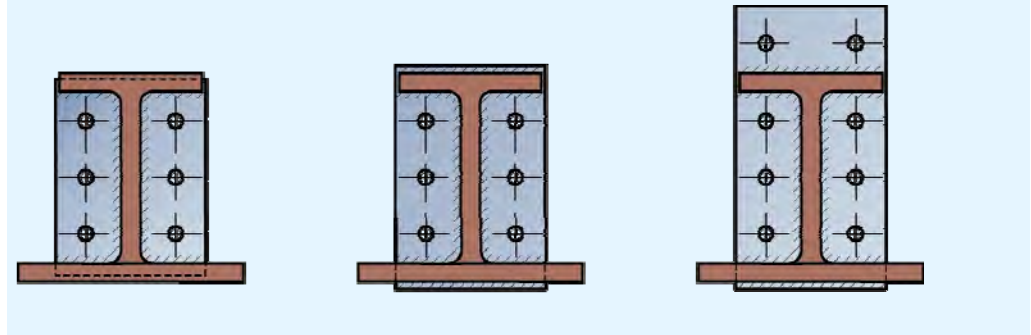

Figure 5.23 Full depth end plates for integrated beams

It is usual practice for the steelwork contractor to design the connections. The frame designer should provide connection shears and torques for the relevant stages, i.e. during construction and in the final state. This is because for many members, torsion may be a feature at the construction stage, when loads are only applied to one side of the member. In this case, both the welds and the bolt group must be checked for the combined effects of the applied torsion and vertical shear.

6 OTHER DESIGN ISSUES

The following design issues will affect the overall building concept, including the structural design aspects.

6.1 Accidental Actions

EN 1990 requires that structures be designed for accidental design situations. The situations that need to be considered are set out in EN 1991-1-7, and these relate to both identified accidental actions and unidentified accidental actions. The strategy to be adopted in either case depends on three “consequence classes” that are set out in EN 1990; for buildings, one of those classes has been subdivided and the categories of building in each class are set out in EN 1991-1-7, Table A.1.

For identified accidental actions, design strategies include protecting the structure against the action but more generally, and for unidentified actions, the structure should be designed to have an appropriate level of “robustness”, defined as:

“The ability of a structure to withstand events like fire, explosions, impact or the consequences of human error, without being damaged to an extent disproportionate to the original cause.”

For unidentified actions, the strategy for achieving robustness is set out in EN 1991-1-7 § 3.3, which says that:

“... the potential failure of the structure arising from an unspecified cause shall be mitigated ... by adopting one or more of the following approaches:

- a) designing key elements on which the stability of the structure depends, to sustain the effects of a model of accidental action Ad;*
- b) designing the structure so that in the event of a localised failure (e.g. failure of a single member) the stability of the whole structure or of a significant part of it would not be endangered;*
- c) applying prescriptive design/detailing rules that provide acceptable robustness for the structure (e.g. three dimensional tying for additional integrity, or a minimum level of ductility of structural members subject to impact).”*

6.1.1 Consequence classes

EN 1990 defines three consequences classes:

- CC1 Low consequences of failure
- CC2 Medium consequences of failure
- CC3 High consequences of failure

Class CC2 is subdivided by EN 1991-1-7 into CC2a (Lower risk group) and CC2b (Upper risk group). Medium rise buildings mostly fall with group CC2b. Examples of categories given by Table A.1 of EN 1991-1-7 include the following:

Table 6.1 Examples of building categorisation (taken from Table A.1 of EN 1991-1-7)

Consequence Class	Example of categorization of building type and occupancy
2B Upper Risk Group	Hotels, flats, apartments and other residential buildings greater than 4 storeys but not exceeding 15 storeys. Educational buildings greater than single storey but not exceeding 15 storeys. Retailing premises greater than 3 storeys but not exceeding 15 storeys. Offices greater than 4 storeys but not exceeding 15 storeys. All buildings to which the public are admitted and which contain floor areas exceeding 2000 m ² but not exceeding 5000 m ² at each storey.

The recommended strategy for Consequence Class 2b involves either the design for localised failure (see Section 6.1.2) or the design of columns as key elements (see Section 6.1.6).

6.1.2 Design for the consequences of localised failure in multi-storey buildings

In multi-storey buildings, the requirement for robustness generally leads to a design strategy where the columns are tied into the rest of the structure. This should mean that any one length of column cannot easily be removed. However, should a length be removed by an accidental action, the floor systems should be able to develop catenary action, to limit the extent of the failure.

It should be noted that the requirements are not intended to ensure that the structure is still serviceable following some extreme event, but that damage is limited, and that progressive collapse is prevented.

6.1.3 Horizontal tying

EN 1991-1-7, A.5 provides guidance on the horizontal tying of framed structures. It gives expressions for the design tensile resistance required for internal and perimeter ties. The calculated tying force is generally equal to the vertical shear.

Tying forces do not necessarily need to be carried by the steelwork frame. A composite concrete floor, for example, can be used to tie columns together, but must be designed to perform this function. Additional reinforcement may be required, and the columns (particularly edge columns) may need careful detailing to ensure the tying force is transferred between column and slab.

If the tying forces are to be carried by the structural steelwork alone, it should be noted that the check for tying resistance is entirely separate to that for resistance to vertical forces. The shear force and tying forces are never applied

at the same time. Furthermore, the usual requirement that members and connections remain serviceable under design loading is ignored when calculating resistance to tying, as ‘substantial permanent deformation of members and their connections is acceptable’. Guidance on the design of connections to resist tying forces is given in *Multi-storey steel buildings. Part 5: Joint design*^[8].

6.1.4 Tying of precast concrete floor units

EN 1991-1-7, §A.5.1 (2) requires that when concrete or other heavy floor units are used (as floors), they should be tied in the direction of their span. The intention is to prevent floor units or floor slabs simply falling through the steel frame, if the steelwork is moved or removed due to some major trauma. Slabs must be tied to each other over supports, and tied to edge beams. Tying forces may be determined from §9.10.2 of BS EN 1992-1-1.

6.1.5 Vertical tying

EN 1991-1-7, A.6 provides guidance on the vertical tying of framed structures. The clause recommends that column splices should be capable of carrying an axial tension equal to the largest design vertical permanent and variable load reaction applied to the column from any one storey. In practice, this is not an onerous obligation, and most splices designed for adequate stiffness and robustness during erection are likely to be sufficient to carry the axial tying force. Guidance on the design of splices to resist tying forces is given in other publications in this series *Multi-storey steel buildings. Part 5: Joint design*^[8].

6.1.6 Key elements

EN 1991-1-7, A.8 provides guidance on the design of “Key elements”. It recommends that a key element should be capable of sustaining an accidental design action of A_d applied in horizontal and vertical directions (in one direction at a time) to the member and any attached components. The recommended value of A_d for building structures is 34 kN/m^2 . Any other structural component that provides “lateral restraint vital to the stability” of a key element should also be designed as a key element.

6.1.7 Risk assessment

Buildings which fall into consequence class 3 have to be assessed using risk assessment techniques. Annex B of EN 1991-1-7 provides information on risk assessment and B.9 provides guidance specific to buildings.

6.2 Floor dynamics

Floor response is assessed first by calculating the fundamental frequency of the floor, and checking this against a limit. Limits are given in National regulations or technical guidance, and may vary between countries. Generally, if the fundamental frequency of the floor structure is greater than 4 Hz, the floor is usually considered to be satisfactory. The natural frequency of the floor is then at least twice the natural frequency due to rapid walking. Whilst this is generally acceptable for busy workplaces, it is not appropriate for quieter areas of buildings where vibrations are more perceptible.

A more appropriate approach is an assessment based on a ‘response factor’ that takes into account the amplitude of the vibration, which is normally measured in terms of acceleration. Allowable response factors are also given in national regulations or technical guidance and may vary between countries. Higher response factors indicate increasingly dynamic floors that are more noticeable to the occupants. A response factor of 8 relative to a base acceleration of 5 mm/s^2 is generally taken to indicate acceptable performance for an office, but it may be necessary to reduce the response factor to (for example) 1 to 2 for a hospital or other specialist rooms.

In practice, response factors are reduced (i.e. vibration is less noticeable) by increasing the mass participating in the motion. Long-span beams are generally less of a dynamic problem than shorter spans, which is contrary to ideas based on natural frequency alone.

Beam layout is often important, as longer continuous lines of secondary beams in composite construction result in lower response factors than shorter lengths, because more mass participates in the motion with longer lines of beams. Figure 6.1 shows two possible arrangements of beams. The response factor for arrangement (b) will be lower (less noticeable to occupants) than arrangement (a), as the participating mass is increased in arrangement (b).

The dynamic response of bare floors during construction is more likely to be perceived than the same floor when furnished and occupied.

Further information on the human induced vibration of steel structures can be obtained from the HIVOSS website^[9].

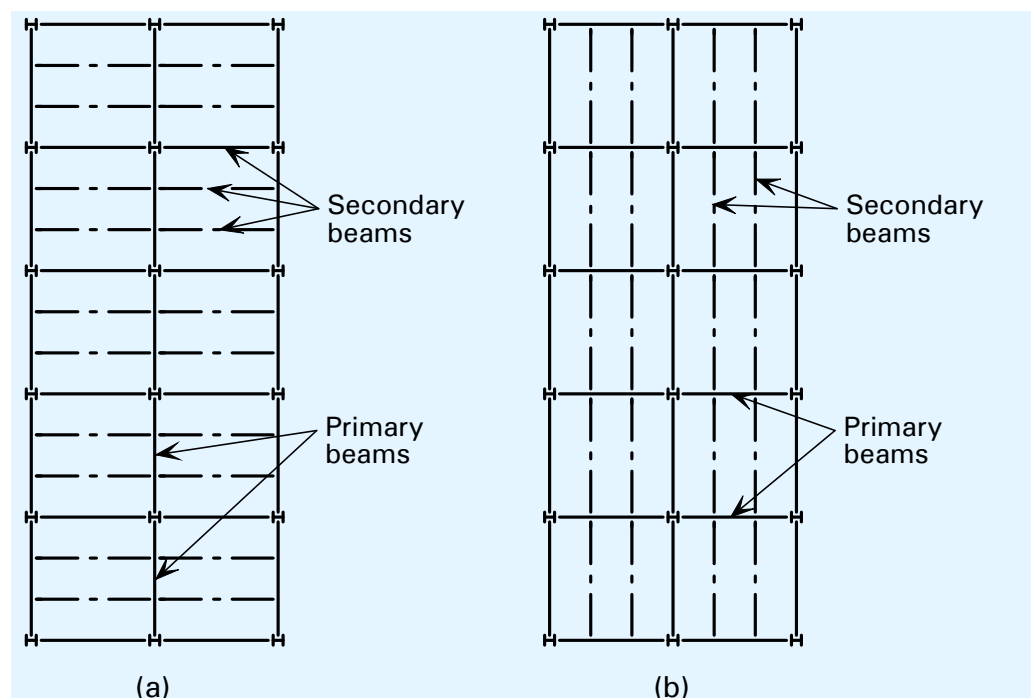

Figure 6.1 Alternative beam layouts

6.3 Corrosion protection

The corrosion of steel is an electrochemical process that requires the simultaneous presence of water and oxygen. In the absence of either, corrosion does not occur. Hence, for unprotected steel in dry environments (e.g. internal steelwork), corrosion will be minimal. The principal factors that determine the rate of corrosion of steel in air are the proportion of total time during which the surface is wet, due to rainfall, condensation etc, and the type and amount of atmospheric pollution (e.g. sulphates, chlorides, etc.).

External steelwork will need corrosion protection. The local environment is important, and can be broadly classified according to EN ISO 12944-2, which describes categories from C1 (heated interiors) through to C5 (aggressive marine or industrial environment). Many corrosion protection systems are available, including metallic coatings (such as galvanising) and paint systems, and should be chosen based on the environment classification.

Occasionally, local regulations demand that even interior steelwork or encased members must have corrosion protection, but in general, hidden steelwork inside dry, heated buildings requires no protection at all.

6.4 Temperature effects

In theory, steel frames expand and contract with changes in temperature. Often, the temperature change of the steelwork itself is much lower than any change in the external temperature, because it is protected.

It is recommended that expansion joints are avoided if possible, since these are expensive and can be difficult to detail correctly to maintain a weather-tight external envelope. In preference to providing expansion joints, the frame may be analysed including the design effects of a temperature change. The temperature actions may be determined from EN 1991-1-5, and combinations of actions verified in accordance with EN 1990. In most cases, the members will be found to be adequate.

Common practice for multi-storey buildings in Northern Europe, in the absence of calculations, is that expansion joints do not need to be provided unless the length of the building exceeds 100 m for simple (braced) frames, and 50m in continuous construction. In warmer climates, common practice is to limit the length to around 80 m. These recommendations apply to the steel frame – expansion joints should be provided in stiff external cladding such as brickwork. When expansion joints in multi-storey buildings are provided, they are commonly arranged to coincide with significant changes of shape on plan, or at significant changes in floor level, or to separate parts of the structure on different foundations.

6.5 Fire safety

Building designers should consider the implications of fire resistance when choosing the structural configuration and should address issues such as:

- Means of escape.

- Size of compartment
- Access and facilities for the Fire Service
- Limiting the spread of fire
- Smoke control and evacuation
- Adoption of sprinklers.

Generally, the above issues are addressed by the scheme architect.

In addition to the above, structural performance in the event of a fire must meet prescribed standards, expressed as a period of fire resistance of the structural components. As an alternative, a ‘fire engineering’ approach may be followed which accounts for the fire safety of the whole building, considering the structure use, the hazards, the risks and how these are addressed.

In general, the structural engineer and architect should consider:

- Schemes which have fewer beams to fire protect
- The opportunity to use unprotected steelwork
- The influence of service integration on the fire protection system, and appropriate solutions such as intumescent coatings on cellular beams
- The influence that site applied protection may have on the construction programme, particularly if the protection is a spray
- Requirements for the final appearance of exposed steelwork when choosing a fire protection system.

Guidance on the fire engineering of multi-storey steel structures is given in *Multi-storey steel buildings. Part 6: Fire engineering*^[10].

6.6 Acoustic performance

Limits on residual noise, after accounting for attenuation by the building façade, are usually specified in National regulations for open plan offices and conference rooms. Criteria are also usually given for the acceptable noise from building services in the same categories.

Maximum and minimum ambient noise level targets are generally defined for spaces within buildings. These are appropriate for comfort in both commercial premises and residential accommodation.

To meet acoustic performance standards, the construction details may require special attention. In Figure 6.2 precast concrete units have an isolated screed (a screed separated from the precast unit by a proprietary resilient layer, or by a waterproof membrane and dense mineral wool). In addition, the ceiling is not in direct contact with the steel beam, and is at least 8 kg/m². Particular attention must also be paid to the junction where walls meet floors and ceilings (known as “flanking” details). An example of a typical flanking detail is shown in Figure 6.3, where there is dense mineral wool around the steel beam, sealant

where the wall finish meets the ceiling, and sealant where the floor treatment meets the wall finish.

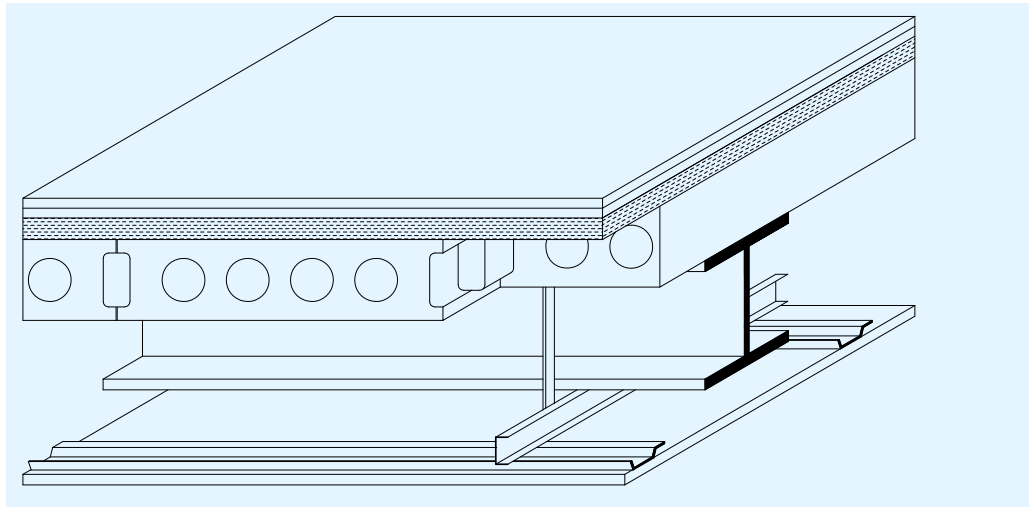

Figure 6.2 Typical floor treatment to provide improved acoustic performance

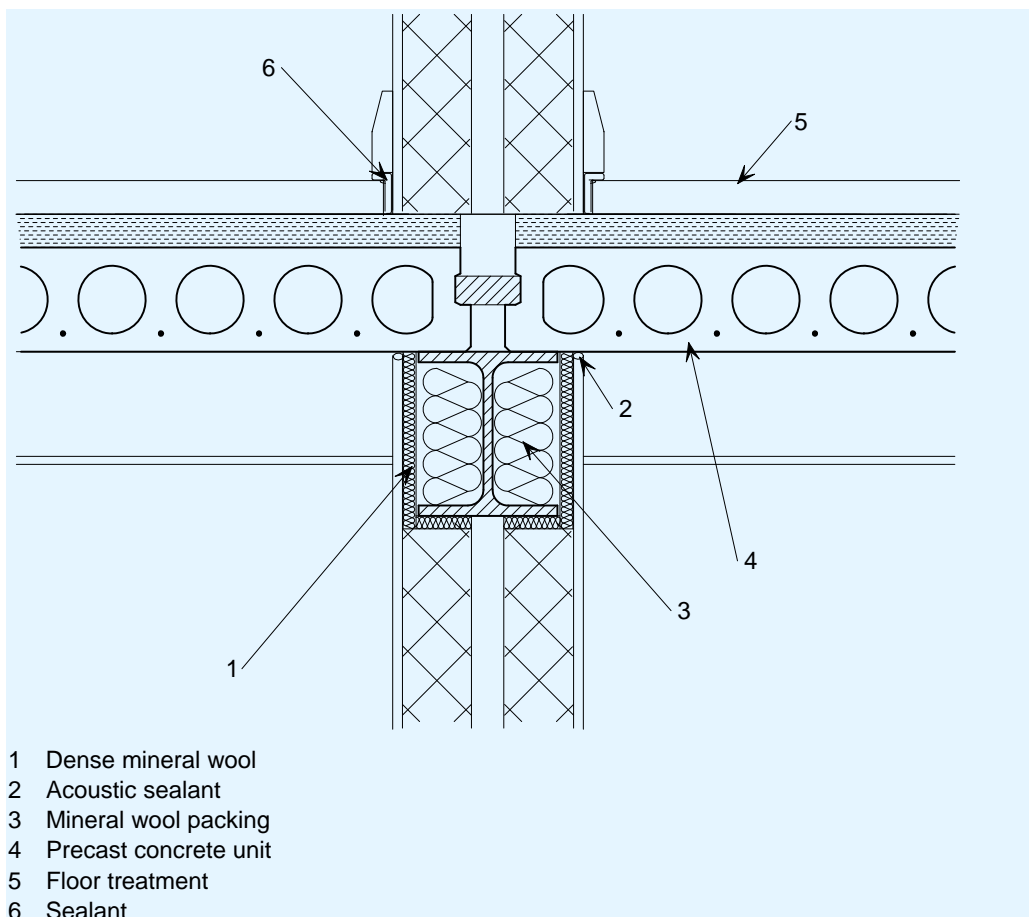

Figure 6.3 Typical flanking detail for an internal separating wall

Separating walls between occupancies are likely to be of double skin construction to reduce noise transmission, facilitating the use of bracing within the wall construction.

6.7 Energy efficiency

Thermal insulation provided in the building envelope is traditionally the architect's responsibility. However, the structural engineer must be involved in the development of appropriate details and layout. Supporting systems for cladding may be more complicated in order to meet thermal performance requirements, involving eccentric connection to the supporting steelwork. Steel members that penetrate the insulation, such as balcony supports, need special consideration and detailing to avoid 'thermal bridging'. Thermal bridges not only lead to heat loss, but may also lead to condensation on the inside of the building.

6.8 Cladding

Cladding systems that may be used in multi-storey building depend on the building height and the degree of fenestration. Fully glazed facades are widely used, although provision for solar shading generally has to be made. An example of a fully glazed cladding is shown in Figure 6.4. The following cladding systems are generally:

- Brickwork
Ground supported up to 3 storeys. Supported by stainless steel angles attached to edge beams for taller buildings
- Glazing systems
Generally triple glazing or double layer facades supported on aluminium posts or glass fins
- Curtain walling
Aluminium or other lightweight façade that is attached to the perimeter steelwork
- Insulated render or tiles
Cladding system supported on light steel infill walls, mainly used in public sector buildings and residential buildings.



Figure 6.4 Triple glazed wall in a multi-storey commercial building

6.8.1 Brickwork cladding

Brickwork cladding is generally supported from the structural frame by continuous angles, bracket angles or individual brackets, often formed from stainless steel to avoid any unsightly staining. Generally, the brackets will have some provision of vertical adjustment, often using two matching plates with serrations on the mating surfaces. Figure 6.5 shows typical fixings to steel beams, where the bracket arrangement is connected to a plate welded between the flanges of the beam.

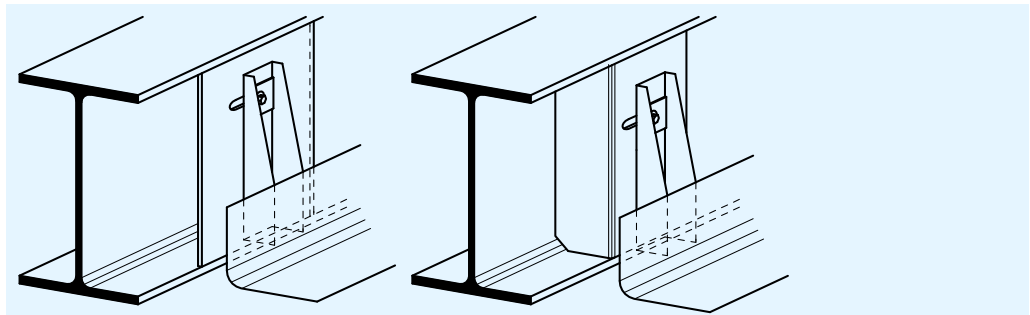

Figure 6.5 Typical fixing details to steel members

Figure 6.6 shows typical fixing details to the edge of concrete slabs. The bracket may fix to the top of the slab, or may connect to a dovetail shaped profile formed in the edge trim of the slab.

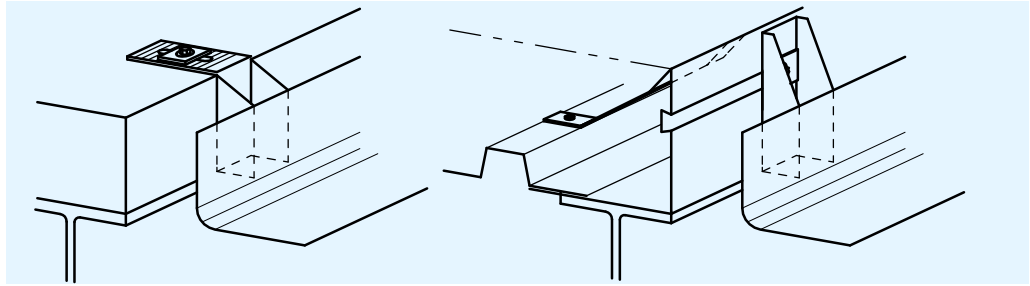

Figure 6.6 Typical fixing details to concrete slabs

6.8.2 Glazing systems

Many steel structures have glazed facades. There are a large number of different systems, and the manufacturer of the system should be consulted when specifying the system, and particularly the fixings to the steel frame. In many cases the fixings will be at the corners of glazed panels, and the panels themselves will have some form of gasket on the joints between panels.

A number of important issues need to be addressed, notably the need to make provision for adjustment in the connections, because the tolerances on the steel frame and the glazing panels are generally different. Movement due to thermal effects may be significant, and this will have to be accommodated in the support system.

6.8.3 Curtain walling

Curtain walling includes:

- Metal panels (generally steel or aluminium)
- Precast concrete panels
- Stone cladding.

Curtain walling may be able to support their own weight and the applied loads without additional structural systems. This type of panel is generally hung, (supported at the top of the panel) or supported at their base from the floor. Generally, each panel system will have a proprietary fixing detail that allows for movement and adjustment in three directions, in order to overcome the difference in tolerances of the frame and cladding panels. The connections can be substantial, and provision may be required to conceal the connections in a raised floor or ceiling zone. The slab design may need review in order to accommodate the local connection forces. It is also common that fixings will be required to the outside edge of a floor, which is usually achieved by a dovetail channel cast into the edge of the slab.

Cladding may require additional structural support – generally in the form of mullions which may extend vertically over a number of floors, possibly with intermediate horizontal members (transoms). Vertical or horizontal metal sheeting is often supported in this way. The connections need careful consideration, to allow for adjustment in three directions, and to allow for movement whilst carrying lateral loads to the floors.

6.8.4 Insulated render cladding and tiles

Insulated render cladding is a lightweight, energy efficient cladding for multi-storey structures, which utilises insulation and render supported by a secondary steel frame, as shown in Figure 6.7. With appropriate detailing and installation, this type of façade can be a fast, robust and highly insulated solution. Tiles may be used as a substitute for the render, and these may be individual tiles or pre-formed panels. Similarly, brickwork can be used as the external skin, as shown in Figure 6.8.

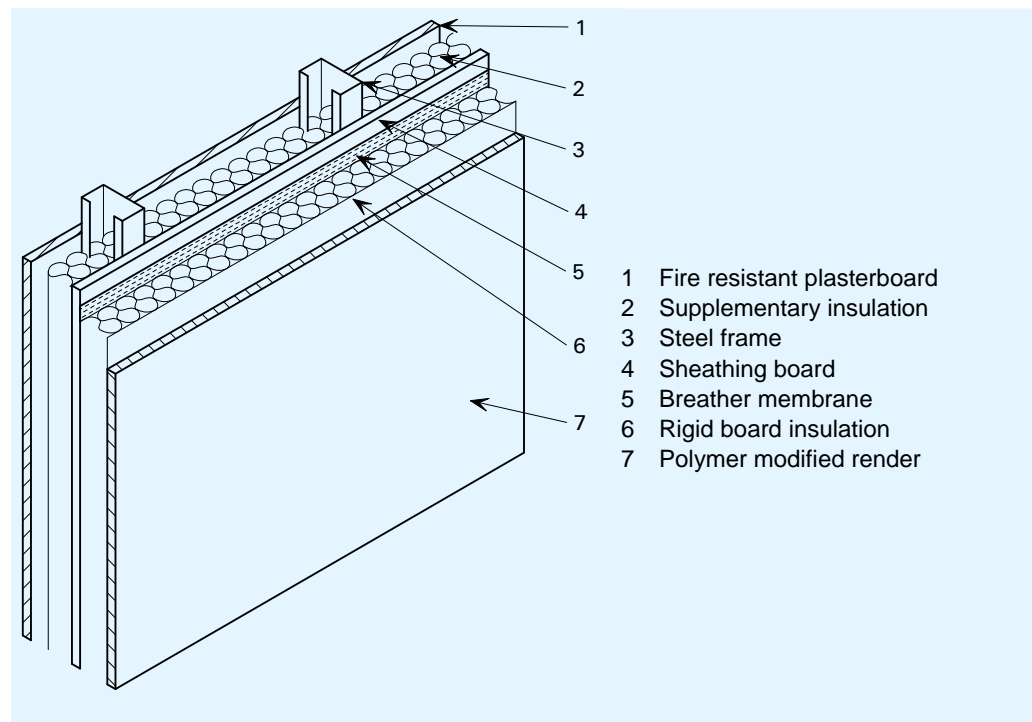

Figure 6.7 Typical insulated render cladding supported by light steel framing

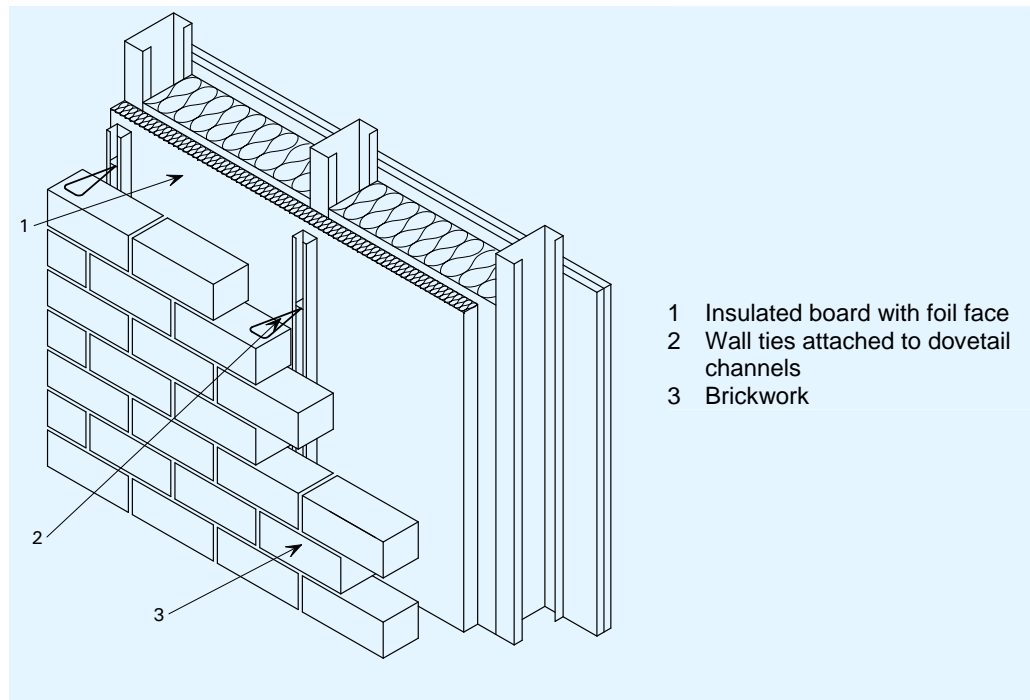

Figure 6.8 Insulated infill panel with brickwork cladding

REFERENCES

- 1 HICKS, S. J., LAWSON, R. M., RACKHAM, J. W. and FORDHAM, P.
Comparative structure cost of modern commercial buildings (second edition)
The Steel Construction Institute, 2004
- 2 Steel Buildings in Europe
Multi-storey steel buildings. Part 3: Actions
- 3 SANSOM, M & MEIJER, J
Life-cycle assessment (LCA) for steel construction
European commission, 2002
- 4 Several assessment methods are used. For example:
 - BREEAM in the UK
 - HQE in France
 - DNGB in Germany
 - BREEAM-NL, Greencalc+ and BPR Gebouw in the Netherlands
 - Valideo in Belgium
 - Casa Clima in Trento Alto Adige, Italy (each region has its own approach)
 - LEED, used in various countries
- 5 GORGOLEWSKI, M.
The role of steel in environmentally responsible buildings
The Steel Construction Institute, 1999
- 6 Steel Buildings in Europe
Multi-storey steel building. Part 4: Detailed design
- 7 SIMMS, W.I.
RT 983: Interim guidance on the use of intumescent coatings for the fire protection
of beams
The Steel Construction Institute, 2004
- 8 Steel Buildings in Europe
Multi-storey steel buildings. Part 5: Joint design
- 9 <http://www.stb.rwth-aachen.de/projekte/2007/HIVOSS/download.php>
- 10 Steel Buildings in Europe
Multi-storey steel buildings. Part 6: Fire engineering