

# AD 355

## Hydrogen embrittlement of bolts

The Advisory Desk has been asked to draw attention to the need to ensure avoidance of hydrogen embrittlement of higher grade bolts (above property class 8.8) that are galvanized or metal coated. This is unrelated to the requirement that bolts have sufficient toughness to meet the requirements for avoidance of brittle fracture at low temperatures, which was discussed in Advisory Desk Note AD 332.

Guidance on avoidance of hydrogen embrittlement in higher grade bolts is given in Guidance Note 8.02 in *Steel Bridge Group: Guidance notes on best practice in steel bridge construction* (SCI publication P185, available on Steelbiz).

Generally, the risk of hydrogen embrittlement is avoided by appropriate treatment during manufacture but it is essential that proper and reliable certification is provided for the bolts and their coating in accordance with the recognised European and international standards.

Contact: **David Iles**  
 Tel: **01344 636525**  
 Email: **advisory@steel-sci.com**

# AD 356

## Design of compression stiffeners to BS EN 1993

This Advisory Desk note presents a summary of the procedure for the design of compression stiffeners in accordance with BS EN 1993.

In BS 5950-1:2000, the need for and design of such stiffeners was covered by clause 4.5.2 (Bearing capacity of web) and clause 4.5.3 (Buckling resistance). In BS EN 1993 the need for compression stiffeners due to transverse force is presented in BS EN 1993-1-5:2006, clause 6 (Resistance to transverse forces).

Although not stated, this clause covers both “web bearing” and “web buckling” mode of failure. If the design resistance of the unstiffened web is insufficient, transverse (compression) stiffeners should be provided in accordance with clause 9.1 and 9.4 of BS EN 1993-1-5:2006.

A summary of the design procedure for compression stiffener designed as a cruciform section (see figure 1 below) is:

Term	Formula	BS EN 1993	Clause	Equation
1 $A_{eff.stiff}$	$(2 \times A_s) + [(2 \times 15 \times \epsilon \times t_w) + t_s] \times t_w$	-1-5	9.1	
2 $I_{eff.stiff}$	$(2 \times L_{s,eff} + t_w)^3 \times t_s / 12$ Excludes web	-1-5	9.1	
3 $i_{eff.stiff}$	$\sqrt{(I_{eff.stiff} / A_{eff.stiff})}$			
4 $\lambda_1$	$93.9\epsilon$	-1-1	6.3.1.3 (1)	
5 $L_{cr} (= \ell)$	$\geq 0.75 \times h_w$	-1-5	9.4 (2)	
6 $\bar{\lambda}$	$L_{cr} / (i_{eff.stiff} \times \lambda_1)$	-1-1	6.3.1.3 (1)	
7 $\alpha$	Imperfection factor = 0.49 Buckling curve ‘c’	-1-5 -1-1	9.4 (2) refers to Table 6.1	
8 $\Phi$	$0.5[1 + \alpha (\bar{\lambda} - 0.2) + \bar{\lambda}^2]$	-1-1	6.3.1.2	6.49
9 $\chi$	$1 / [\Phi + \sqrt{(\Phi^2 - \bar{\lambda}^2)}]$ $\chi \leq 1.0$	-1-1	6.3.1.2	6.49
10 $N_{b,Rd}$	$\chi \times A_{eff.stiff} \times f_y / \gamma_{M1}$	-1-1	6.3.1.1 (3)	6.47

**Table Notes:**

Read in conjunction with figure 1 opposite.

- Formulae 1, 2 and 3 are for a symmetrical stiffener arrangement.
- Refer to EN 1993-1-5: 2006 – clause 9.1 (2) for limiting web lengths
- Effective stiffener length,  $L_{s,eff} = \min(L_s, 14 \times t_s \times \epsilon)$ .  
( $14 \times t_s \times \epsilon$ ) is from BS EN 1993-1-1, Table 5.2 (class 3, outstand)
- $A_s = L_{s,eff} \times t_s$
- $\epsilon = \sqrt{(235/f_y)}$
- $f_y = \min(f_{y,stiff}, f_{y,beam})$
- $h_w$  = clear depth between flanges (not depth between fillets)
- $\gamma_{M1} = 1.0$  (UK National Annex)

Contact: **Abdul Malik**  
 Tel: **01344 636525**  
 Email: **advisory@steel-sci.com**

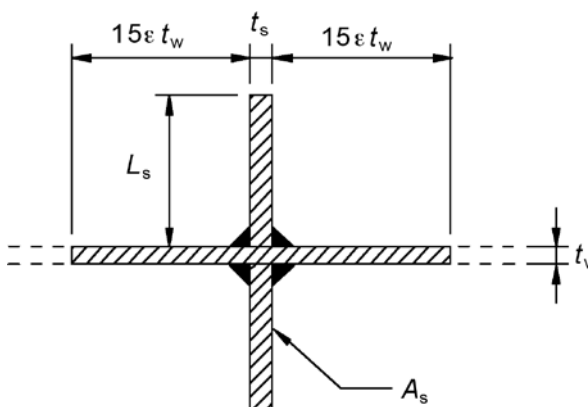

Figure 1. Effective cross-section of stiffener